

up to 106 l/min  
up to 350 bar

## FUNCTION

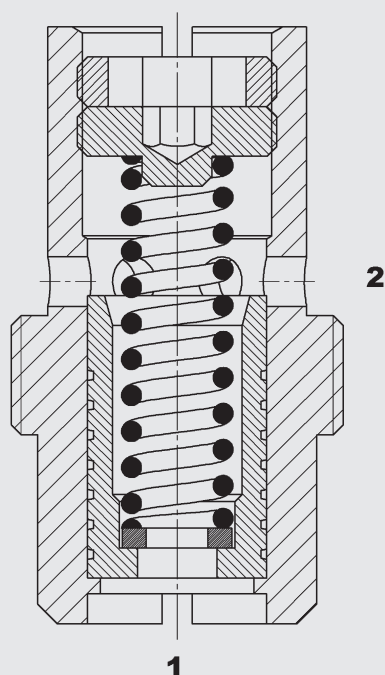

The SRE is a pressure compensated flow control valve which maintains a constant outlet flow by means of a control function. The flow rate is largely independent of the pressure and viscosity.

The valve has a fixed orifice with pressure compensator spool. The measuring orifice determines the setting range for the flow rate which can be adjusted over a small range. If oil is flowing from 1 to 2, a pressure drop occurs at the measuring orifice. The pressure compensator moves into the control position which corresponds to the force equilibrium. This is created by the pressure drop acting on the control piston area overcoming the spring force.

As the flow rate increases (greater pressure drop), the diameter of the control orifice is reduced until the forces are equal again. A constant flow rate is therefore achieved. In the reverse direction there is free flow through the valve.

**Important:** if the required control pressure differential is not reached, the valve operates as a non-compensated flow control valve.

## 2-Way Flow Regulator Pressure Compensated Direct-Acting Cartridge – 350 bar SRE 1 to 4

### FEATURES

- For regulating the speed of loads independently of the pressure
- For limiting the max. speed of lifting gear (in compliance with accident prevention regulations)
- For limiting the flow rate for control oil circuits in the main circuit and offline
- Choice of four sizes for optimum adaptability to the system
- Space-saving installation
- Unauthorized adjustment not possible since not accessible once fitted

### SPECIFICATIONS\*

Operating pressure:	max. 350 bar
Nominal flow:	SRE1: 0.6 to max. 15 l/min SRE2: 1.0 to max. 23 l/min SRE3: 1.7 to max. 48 l/min SRE4: 2.0 to max. 106 l/min
Media operating temperature range:	min. -30 °C to max. +100 °C
Ambient temperature range:	min. -30 °C to max. +100 °C
Operating fluid:	Hydraulic oil to DIN 51524 Part 1, 2 and 3
Viscosity range:	min. 2.8 mm <sup>2</sup> /s to max. 380 mm <sup>2</sup> /s
Filtration:	Class 21/19/16 according to ISO 4406 or cleaner
MTTF <sub>d</sub> :	150 - 1200 years, according to DIN EN ISO 13849-1
Installation:	No orientation restrictions, preferably horizontal
Materials:	Valve body: steel
Cavity:	05520, 08520, 10520, 12520
Weight:	SRE1= 0.013 kg    SRE2= 0.025 kg SRE3= 0.049 kg    SRE4= 0.112 kg

\* see "Conditions and instructions for valves" in brochure 53.000

## MODEL CODE

SRE 1 - G 1/4 - 01 X / 2.3 - 2.8

### Basic model

Flow regulator

### Cartridge thread size

G 1/4 = SRE1

G 3/8 = SRE2

G 1/2 = SRE3

G 3/4 = SRE4

### Type

01 = standard (burnished)

### Series

(determined by manufacturer)

### Flow rate code

(see separate flow rate table)

### Flow rate setting value

no details = valve is not set

(but the flow rate is within the setting range)

2.8 = setting value as per customer requirements (tolerance  $\pm 10\%$ )

Other settings on request

### Flow rate and operating pressure ranges

Flow rate code (VK)	Flow rate setting range (l/min)	Required control pressure differential $\Delta p = p_1 - p_2$ [bar]	
0.6	0.6 – 0.7	10 – 12	
1	1.0 – 1.3	10 – 12	
1.6	1.6 – 2.1	10 – 12	
2.3	2.3 – 3.0	10 – 12	SRE 1
3.8	3.8 – 4.8	10 – 15	
6.6	6.6 – 8.6	10 – 15	
1	1.0 – 1.5	8 – 15	
1.5	1.5 – 2.4	8 – 15	
2.9	2.9 – 4.6	8 – 15	SRE 2
5	5.0 – 7.5	10 – 15	
9	9.0 – 13.0	12 – 18	
15	15.0 – 23.0	12 – 18	
1.7	1.7 – 2.1	8 – 12	
2.8	2.8 – 3.8	8 – 12	
4.5	4.5 – 5.5	8 – 15	
7	7.0 – 9.2	8 – 15	
10	10.0 – 12.5	8 – 15	SRE 3
15.5	15.0 – 18.0	8 – 15	
26	25.5 – 30.0	8 – 15	
35	35.0 – 42.0	10 – 18	
42	41.0 – 48.0	10 – 18	
27	27.0 – 29.4	12 – 15	
40	40.0 – 42.9	12 – 15	
46	46.0 – 49.9	12 – 15	
55	55.0 – 59.9	13 – 17	SRE 4
70	70.0 – 78.9	15 – 18	
88	88.0 – 97.0	18 – 21	

### Important:

– if the required control pressure differential is not reached, the valve operates as a non-compensated throttle valve.

– different settings are available as an option (standard manufacturer's setting at  $\Delta p = 100$  bar)

## FLOW RATE CURVES

### Q- $\Delta p$ curve

Pressure differential  $\Delta p$  against flow rate Q, measured at  $v = 72 \text{ mm}^2/\text{s}$  and  $T_{01} = 30 \text{ }^\circ\text{C}$

VK = Flow rate code

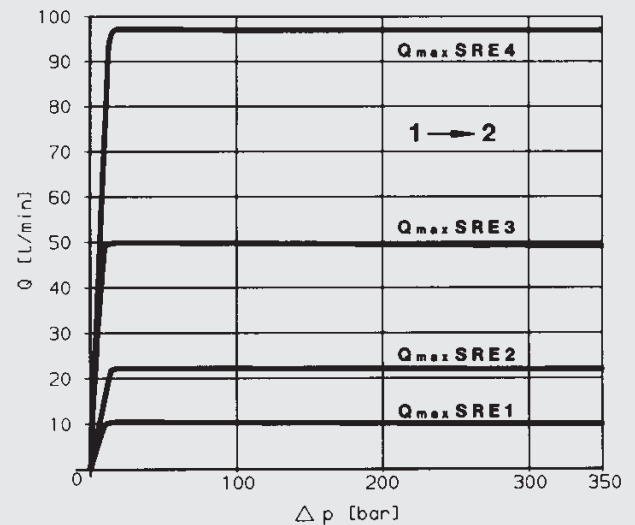

### Standard models

Model code	Part No.
SRE1-G1/4-01X/1.6	717583
SRE1-G1/4-01X/3.8	710355
SRE1-G1/4-01X/6.6	710351
SRE2-G3/8-01X/2.9	717586
SRE2-G3/8-01X/9.0	717588
SRE2-G3/8-01X/15	717590
SRE3-G1/2-01X/7.0	717689
SRE3-G1/2-01X/15.5	717691
SRE3-G1/2-01X/26	717693
SRE4-G3/4-01X/70	717825
SRE4-G3/4-01X/88	479390

Other models on request

### Standard in-line bodies

Code	Part No.	Material	Ports	Pressure
Port: 1x female thread, 1x male thread				
XB05520-01X	393215	Steel	G1/4	350 bar
XB08520-01X	393217	Steel	G3/8	350 bar
XB10520-01X	393219	Steel	G1/2	350 bar
XB12520-01X	395061	Steel	G3/4	350 bar
Port: 2x female thread				
XX05520-01X	393224	Steel	G1/4	350 bar
XX08520-01X	393226	Steel	G3/8	350 bar
XX10520-01X	393228	Steel	G1/2	350 bar
XX12520-01X	395063	Steel	G3/4	350 bar

## PERFORMANCE

Flow rate, pressure-dependent  
 Q- $\Delta p$  curve,  
 measured at  $v = 72 \text{ mm}^2/\text{s}$  and  $T_{01} = 30 \text{ }^\circ\text{C}$   
 $\Delta p_{\text{max } 2} \rightarrow$ : 250 bar

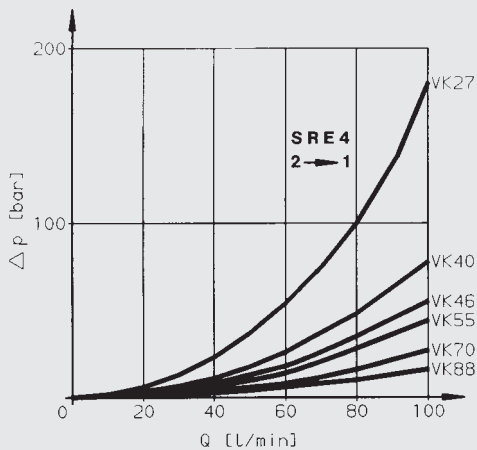
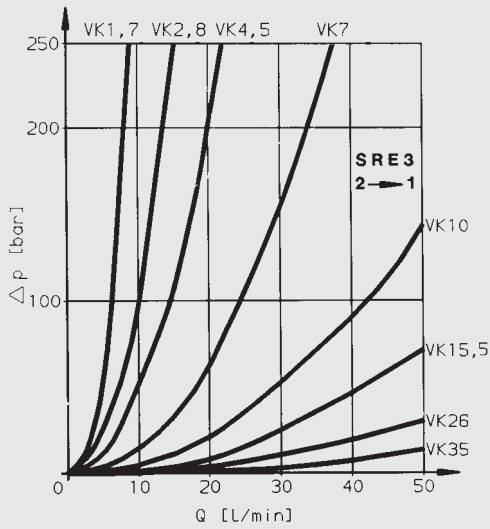
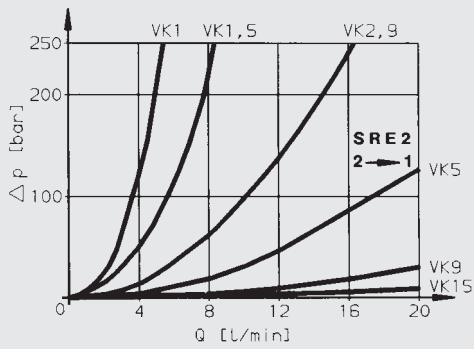
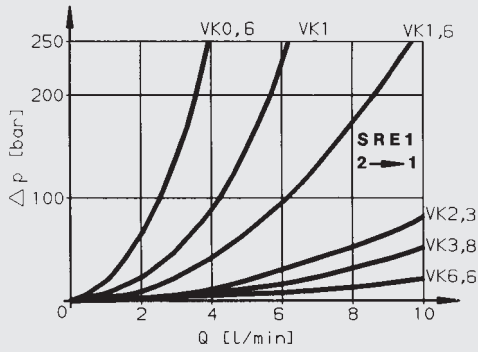

## DIMENSIONS

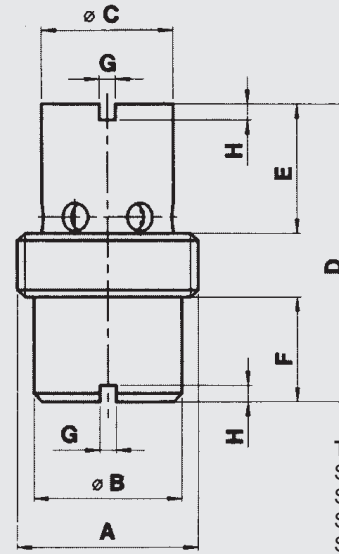

Torque	
SRE1	3 - 5 Nm
SRE2	5 - 8 Nm
SRE3	8 - 12 Nm
SRE4	12 - 18 Nm

Size	A	$\varnothing B$	$\varnothing C$	D	E	F	G	H
SRE1	G 1/4	11.0	10.0	26.0	14.0	6.5	1.5	1.5
SRE2	G 3/8	14.0	13.0	30.0	14.5	9.5	1.5	1.5
SRE3	G 1/2	18.0	16.0	37.0	16.0	13.0	2.0	2.0
SRE4	G 3/4	23.0	20.0	51.0	21.0	20.0	4.0	2.0

## CAVITY

05520

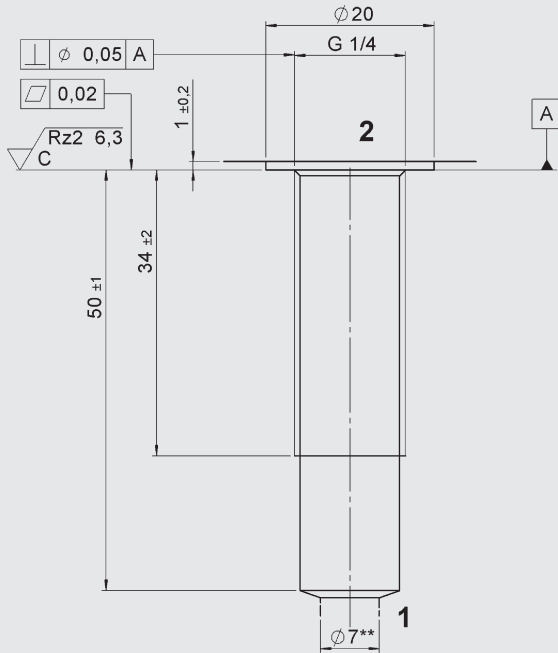

## CAVITY

08520

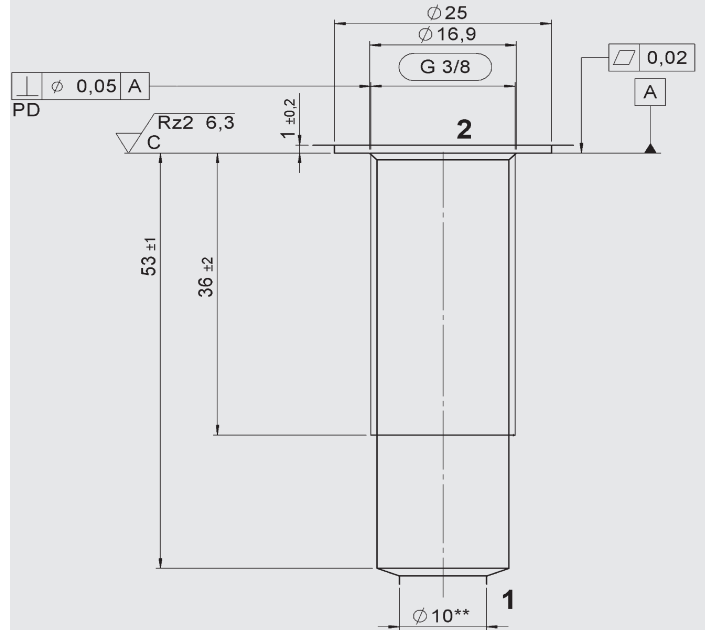

## CAVITY

10520

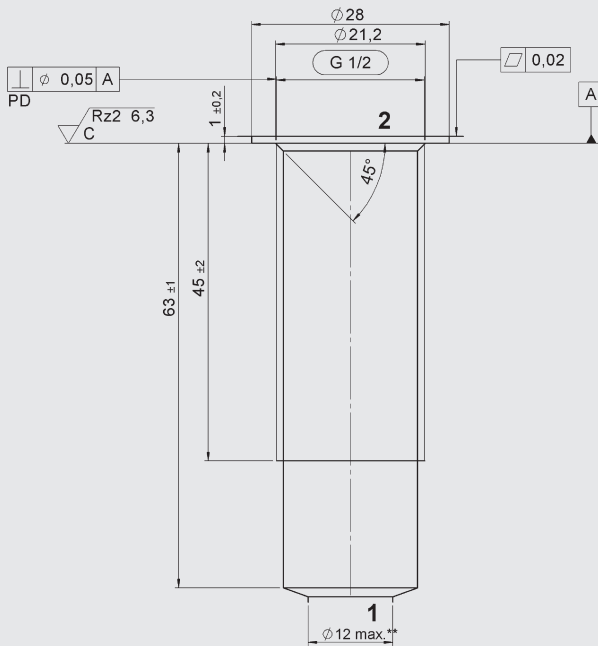

## CAVITY

12520

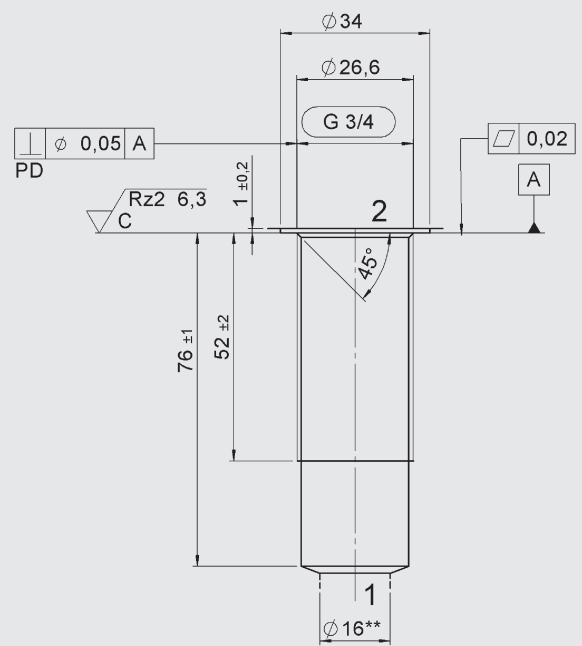

### Form tools

Tool	Part No. / Cavity			
	05520	08520	10520	12520
Tap	1002670	1002668	1002667	1002663

### NOTE

The information in this brochure relates to the operating conditions and applications described. For applications or operating conditions not described, please contact the relevant technical department.  
Subject to technical modifications.

### HYDAC Fluidtechnik GmbH

Justus-von-Liebig-Str.  
D-66280 Sulzbach/Saar  
Tel: 0 68 97 /509-01  
Fax: 0 68 97 /509-598  
E-Mail: valves@hydac.com