

HYDAC

INTERNATIONAL

**HYDAC Fluidtechnik
Industrial Valves**



CONTENT

DIRECTIONAL VALVES (direct-acting)

5	4WE 6	Directional spool valves NG6
13	4WE 6 A08	Directional spool valves, 8 watt NG6
21	4WE 10	Directional spool valves NG10
NN*	4WEW 6	Soft-shift directional spool valves NG6
29	4WEW 10	Soft-shift directional spool valves NG10
37	WSE 6	Directional poppet valves NG6
45	WSER 6	Directional poppet valves with position monitoring NG6
55	4WMH 6 to 10	Directional spool valves, manually operated

DIRECTIONAL VALVES (pilot operated + main stage)

63	4WH 10	Main stage NG10
71	4WH 16	Main stage NG16
79	4WH 25	Main stage NG25
87	4WH 32	Main stage NG32
95	4WEH 10 to 32	Pilot operated directional spool valves

SANDWICH PLATES

109	ZW 6
133	ZW 10
155	ZW 16
171	ZW 25

PROPORTIONAL VALVES (direct-acting)

183	P4WE 6	Proportional directional valves NG6
191	P4WE 10	Proportional directional valves NG10
197	P4WER 6	Proportional directional valves NG6 with transducer
203	P4WEE 6	Proportional directional valves NG6 with Onboard-Electronic (OBE)
213	P4WEE 10	Proportional directional valves NG10 with Onboard-Electronic (OBE)
221	P4WERE 6	Proportional directional valves NG6 with transducer + OBE
229	P4WERE 10	Proportional directional valves NG10 with transducer + OBE

PROPORTIONAL VALVES (pilot operated)

237	P4WEH 10 to 32	Pilot operated proportional directional valves
247	P4WEHE 10 to 32	Pilot operated proportional directional valves with OBE
261	P4WEHRE 10 to 25	Pilot operated proportional directional valves with transducer + OBE

CONTENT

CONTROL VALVES (direct-acting)

273	C4WERE 6
NN*	C4WERE 10

PLATE MOUNTED VALVES

281	VP-DBP10	Pilot operated pressure relief valves NG10
NN*	VP-DRP10	Pilot operated pressure control valves NG10
NN*	VP-2SR6	Flow regulating valves, pressure-compensated NG6
NN*	VP-2SR10	Flow regulating valves, pressure-compensated NG10
NN*	VP-RP10	Check valves, pilot-to-open NG10
285	VP-PDB6	Direct-acting proportional pressure relief valves NG6
NN*	VP-PDBP10	Pilot operated proportional pressure relief valves NG10
289	VP-P2SRE6	Direct-acting proportional flow regulating valves NG6
293	VP-P2SRR6	Direct-acting proportional flow regulating valves with transducer NG6

LOGIC VALVES + LOGIC COVERS

297	L-CEE	2/2 way cartridge valves
309	LD-CCE	Control covers for 2/2 way cartridge valves

329 ACCESSORIES FOR INDUSTRIAL VALVES

4/2- and 4/3-directional spool valve solenoid-operated, direct-acting 4WE 6

DESCRIPTION

HYDAC 4/2- and 4/3- directional spool valves of the 4WE 6 series are directional valves for oil hydraulic systems which are used to open and close flow paths. The valve operates by oil-immersed solenoid. During this process, the solenoid pushes the valve's control spool into the respective position to obtain the desired flow path.

FEATURES

- Direct-acting, solenoid-operated directional valve
- Interface according to DIN 24340 Form A6, ISO 4401-03
- Removable high-performance solenoid coil, no need to open the hydraulic system during replacement
- Coil rotatable by 360° allows flexible installation
- Electrical connection in several versions available
- With concealed manual override, additional versions available
- With increased corrosion protection due to zinc-nickel surface coating as an option (A40)

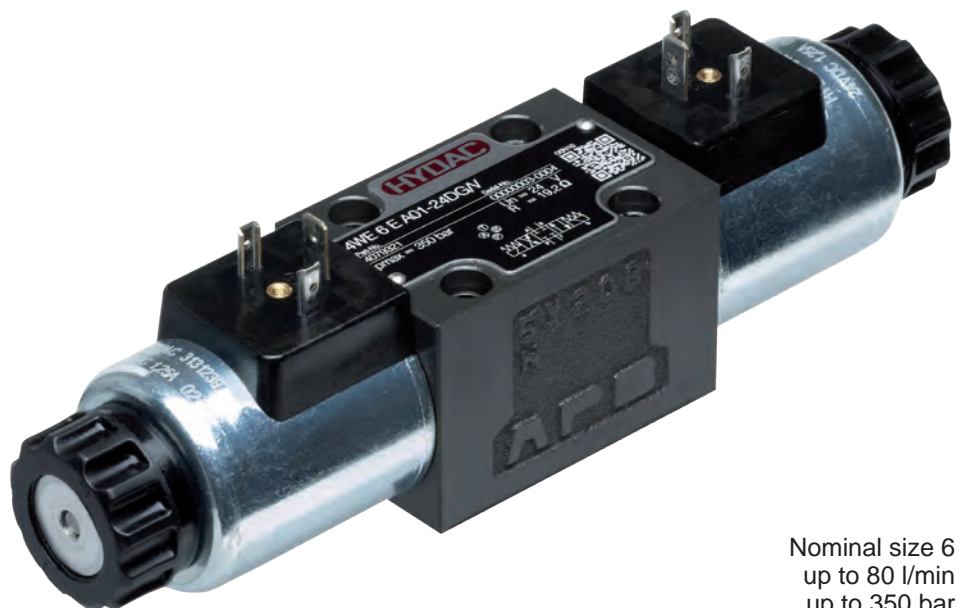

Nominal size 6
up to 80 l/min
up to 350 bar

CONTENTS

Description
Features
Model code
Spool types / symbols
Function
Section view
Technical data
Performance
Dimensions
Electrical connections
Manual overrides
Accessories

MODEL CODE

4WE 6 D - OF A01-24 D G /V

Type

Solenoid-operated directional valve with 4 main ports, direct-acting

Nominal size

6

Spool symbol

See page 7

Version

Not specified = with return spring

-OF = without return spring, with detent (with D symbol only)¹⁾

Series

A01 = specified by the manufacturer

A40 = with zinc nickel coating

Rated voltage of the solenoid coil ¹⁾

12 = 12 VDC

24 = 24 VDC

96 = 96 VDC*

205 = 205 VDC*

110 = 110 VAC*

230 = 230 VAC*

* only in combination with the electrical connection G

Type of voltage

D = DC voltage

A = AC voltage (only in combination with electrical connection G)

Electrical connection (for details, see page 11)

G = device connector, DIN EN 175301-803 A

L = single leads

L02 = single leads with suppressor diode

N = device connector, Deutsch

N01 = device connector, Deutsch with suppressor diode

O = device connector, M12

U = device connector, Junior Timer

U01 = device connector, Junior Timer with suppressor diode

Sealing material ¹⁾

/N = NBR

/V = FKM (standard)

Manual override (for details, see page 11)

Not specified = with concealed manual override (standard)

/M1 = with manual override

/M2 = with covered manual override

/M4 = with knurled nut

/M5 = with mushroom head (lockable)

/M6 = with mushroom head (not lockable)

Orifice insert ¹⁾

Not specified = no orifice insert

/YXX = Y = connection P, A, B, T

XX = diameter (e.g. 12 = 1.2 mm); preferred series: 0.8 mm; 1.0 mm; 1.2 mm

¹⁾ Other models on request

SPOOL TYPES / SYMBOLS

4/2-DIRECTIONAL SPOOL VALVES

Type	Basic symbol	With intermediate position
AE		
BE		
C		
D		
DT		
DB		
EA		
EB		
GA		
GB		
HA		
HB		
JA		
JB		
KA		
QA		
UA		
Y		
YT		

With return spring

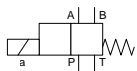

With detent (...-OF)

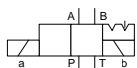

4/3-DIRECTIONAL SPOOL VALVES

Type	Basic symbol	With intermediate position
E		
F		
G		
H		
J		
JR		
K		
L		
M		
P		
Q		
R		
U		

FUNCTION

The solenoid-operated directional spool valves of the 4WE 6 type are used to direct nominal flow and consist of one valve housing (1) with an associated valve spool (2). Depending on the type, the valve is equipped with at least two return springs (3) and with one or two pole tubes (4) and solenoid coils (5) each.

The hydraulic control of the valve is carried out through the actuation of the valve spool by the use of solenoids (5). A solenoid is a converter which converts electrical energy into mechanical energy. The energised solenoid causes the oil-immersed magnetic piston to make a linear stroke movement. It uses the guide rod (6) to move the valve spool into the desired position. This causes the nominal flow directions between the respective ports to be released or closed. To obtain the valves' optimum switching capacity, the pressure-tight chamber of the pole tube should always be filled with oil.

The valve spool is pushed back into the starting position by the appropriate return spring after de-energization of solenoid.

The manual override (7) enables valve operation without energising the solenoid.

Without return spring with detent "OF"

This alternative describes the so-called impulse valve. This is a 4/2-directional valve with 2 solenoids and detent. The detents are used to lock the valve spool in the respective switching position. There is no need to permanently energise the solenoid, which consequently contributes to energy-saving operation.

SECTION VIEW

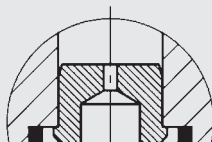
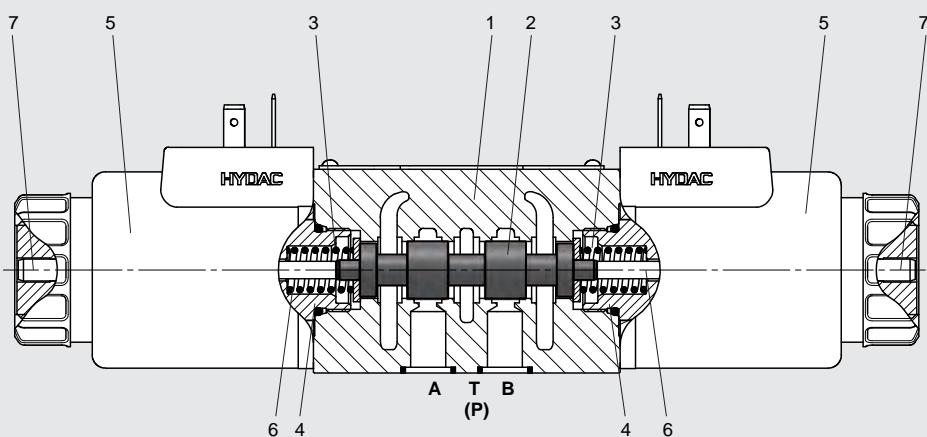

Orifice insert

Used to reduce nominal flows that are too high and outside of the valve's operating limits.

TECHNICAL DATA ¹⁾

General specifications			
MTTF _d :		According to EN ISO 13849-1:2015 Tables C1 & C2	
Ambient temperature range:	[°C]	-20 to +60	
Installation position:		No orientation restrictions	
Weight:	[kg]	1.5 with one solenoid; 2.0 with two solenoids	
Material:	Valve casing:	Cast iron	
	Pole tube:	Steel	
	Coil casing:	Steel	
	Name plate:	Aluminium	
Surface coating:	Valve casing:	Phosphate plated	
	Pole tube:	Zn-coating	
	Coil casing:	ZnNi-coating	
Hydraulic specifications			
Operating pressure:	[bar]	Connection A, B, P: $p_{max} = 350$ Connection T: $p_{max} = 210$	
Nominal flow:	[l/min]	See performance limits on page 9	
Operating fluid:		Hydraulic oil to DIN 51524 Part 1, 2 and 3	
Media operating temperature range:	[°C]	-20 to +80 (for standard sealing)	
Viscosity range:	[mm ² /s]	10 to 500	
Permitted contamination level of operating fluid:		Class 20/18/15 according to ISO 4406	
Max. switching frequency:	[1/h]	15,000	
Manual override:		Possible up to approx. 50 bar tank pressure	
Sealing material:		FKM (standard), NBR	
Electrical specifications			
Switching time:	[ms]	Energised: approx. 20 – 70 De-energised: approx. 10 – 60	
Type of voltage:		DC	AC
Rated voltage:	[V]	12, 24, 96, 205	110, 230
Voltage tolerance:	[%]	±10	
Nominal power:	[W]	30	
Duty cycle:	[%]	100	
Max. surface temperature of the coil:	[°C]	150	
Protection class according to DIN EN 60529:	With electrical connection "G"	IP65 *	
	With electrical connection "L"	IP65 *	
	With electrical connection "N"	IP65 / IP67 *	
	With electrical connection "O"	IP65*	
	With electrical connection "U"	IP65 *	

¹⁾ see "Conditions and instructions for Valves" in brochure 53.000

²⁾ if installed correctly

PERFORMANCE

Pressure drop

measured at $v = 35 \text{ mm}^2/\text{s}$, $T = 45 \text{ }^\circ\text{C}$

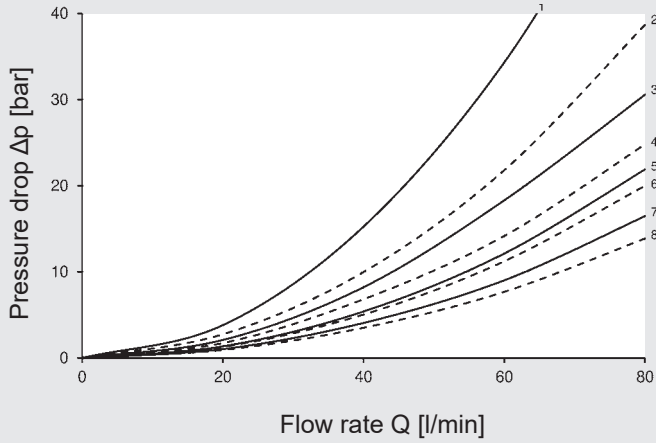

Performance limits

measured at $v = 30 \text{ mm}^2/\text{s}$, $T = 50 \text{ }^\circ\text{C}$

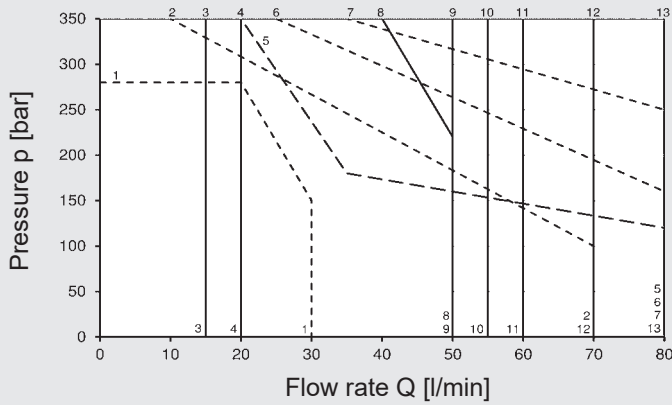

Performance assignment to the associated spools:

Spool	Pressure drop					Performance limits
	P→A	B→T	P→B	A→T	P→T	
AE	–	–	7	7	–	2
BE	7	7	–	–	–	2
C	8	8	8	8	–	10
D	8	7	8	7	–	12
DB	3	6	3	6	–	4
D-OF	8	7	8	7	–	13
DT	8	–	7	–	–	5
E, EA, EB	7	7	7	7	–	13
F	6	6	6	6	–	1
G, GA, GB	1	1	1	1	4	9
H, HA, HB	8	8	8	8	4	13
J, JA, JB	7	7	7	7	–	7
JR	–	–	2	8	–	6
K, KA	8	7	7	7	–	13
L	7	7	7	8	–	13
M	8	5	8	5	–	13
P	6	6	6	6	–	4
Q, QA	7	7	7	7	–	11
R	–	–	3	6	–	8
U, UA	7	8	7	7	–	13
Y	7	8	7	8	–	12
YT	7	–	8	–	–	3

The performance limits were determined with solenoids at operating temperature and 10 % low voltage.

The specified performance limits are applicable for operation with two directions of flow. The performance capacities may be lower when there is only one flow direction.

Restricted switching capacity for G96/G205 coils:

The max. permitted nominal flow specified in the diagram must be reduced by 10%. The switching times are extended.

DIMENSIONS

Interface according to ISO 4401-03-02-0-05

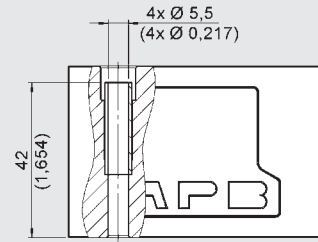
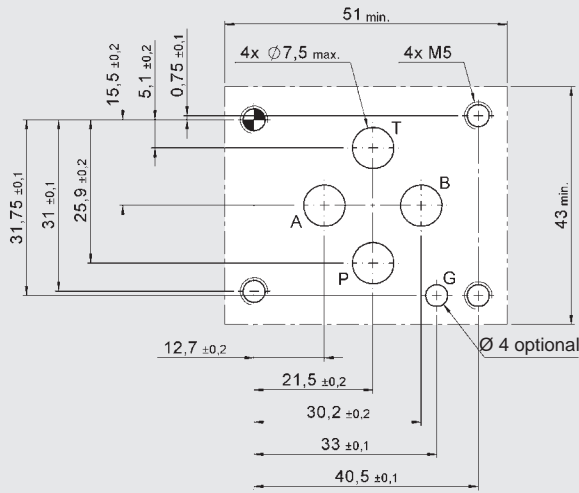

Mounting screws:
 (not included in delivery)
 DIN EN ISO 4762 – M5 x 50 – 10.9
 Tightening torque: 7 Nm

With two solenoids

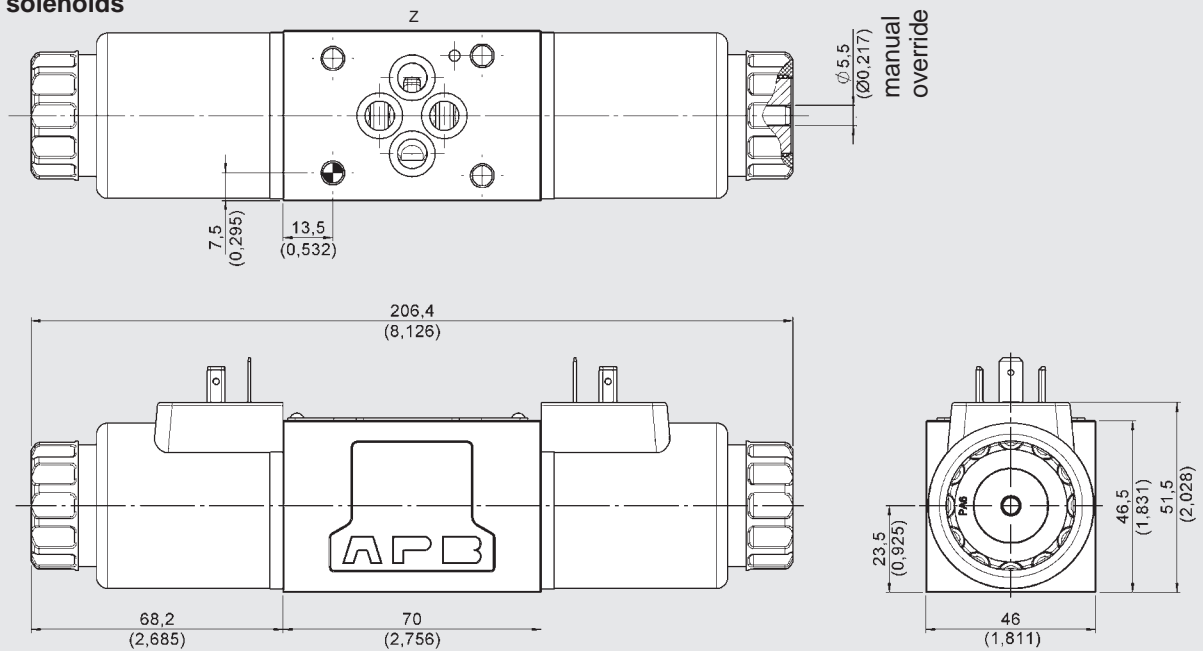

With one solenoid

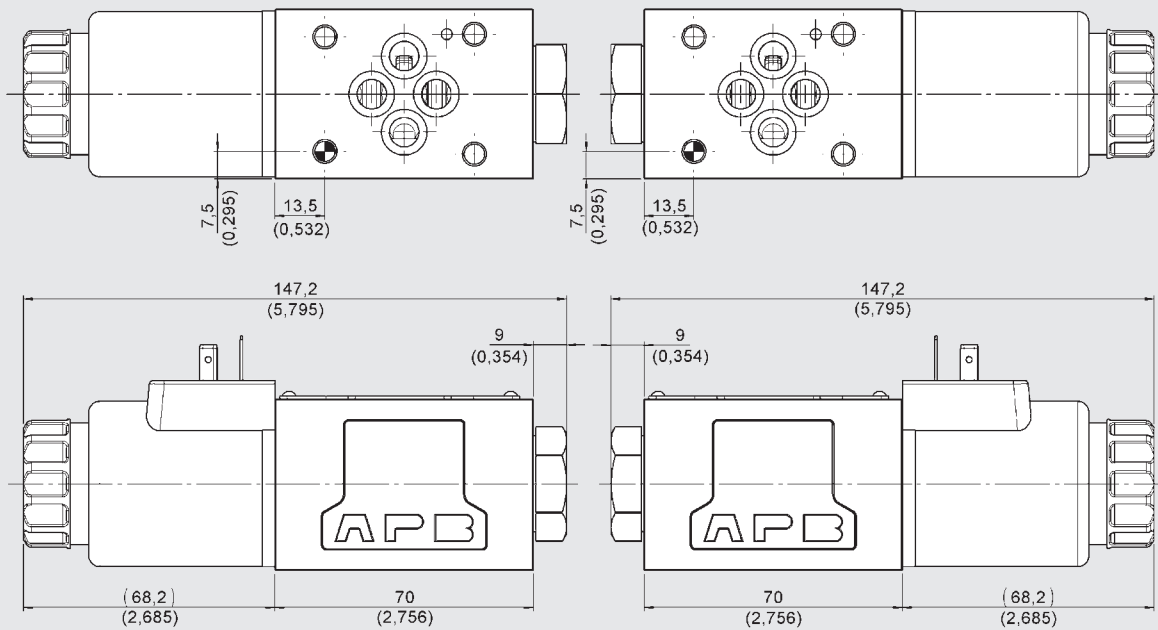

Valve with solenoid a

Valve with solenoid b

ELECTRICAL CONNECTIONS

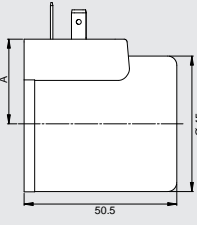
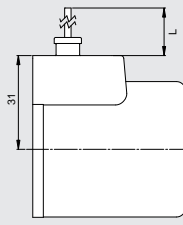
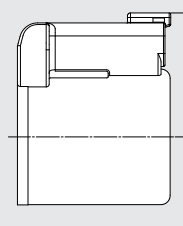
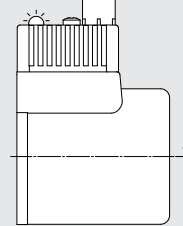
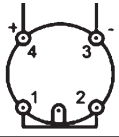
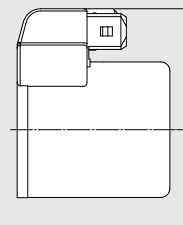
G Device connector DIN EN 175301-803 A		<ul style="list-style-type: none"> ● IP65 ● A = 28 mm for DC (DG) ● A = 30.7 mm for AC (AG)
L 2 strands		<ul style="list-style-type: none"> ● IP65 ● Standard strands length L = 457 mm ● Optional with suppressor diode
N Device connector, Deutsch (DT04-2P)		<ul style="list-style-type: none"> ● IP65 / IP67 ● Optional with suppressor diode
O Device connector M12		<ul style="list-style-type: none"> ● IP65 ● With yellow LED as operation indicator ● Pin assignment 
U Device connector Junior Timer (axial)		<ul style="list-style-type: none"> ● IP65 ● Optional with suppressor diode

Other models on request

MANUAL OVERRIDES

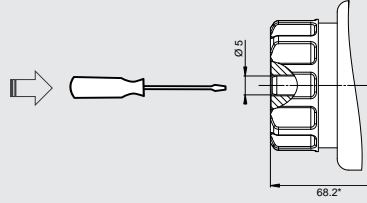
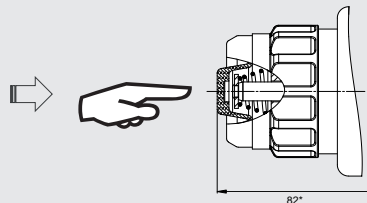
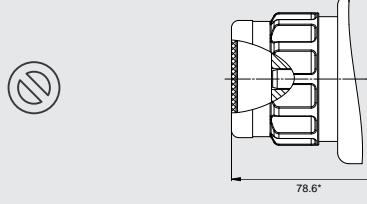
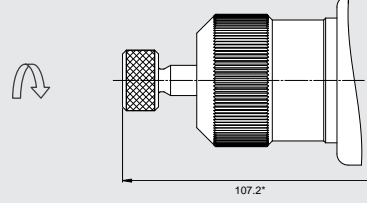
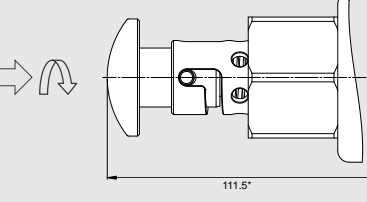
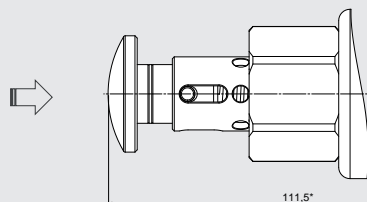
Standard with concealed manual override		Operation with tool
M1 with manual override		Operation without tool with spring return
M2 with covered manual override		Manual override covered, operation only possible after disassembly of cap
M4 with knurled-head screw		Operation by turning the knurled-head screw
M5 with mushroom head (lockable)		Operation by pressing, locking by subsequently turning the mushroom button
M6 with mushroom head (not lockable)		Operation by pressing the mushroom button

* Dimensions up to valve housing

In case of emergency, the valve can also be operated manually. There are different forms of manual override available.

The tank pressure should not exceed 50 bar. If the tank pressure is higher, the force required to operate the manual override increases accordingly.

For valves with two solenoids, simultaneous operation of both manual overrides is not permitted.

ACCESSORIES

	Designation	Part no.
Seal kits (4-part set)	9.25 x 1.78 80 Sh NBR	3492432
	9.25 x 1.78 80 Sh FKM	3120269
Mounting screws (4 pcs)	DIN EN ISO 4762 - M5 x 50 - 10.9	4312231
Solenoid coils	COIL 12DG -50-2345 -S	4244169
	COIL 12DN -50-2345 -S	4244170
	COIL 12DO -50-2345 -S	4250874
	COIL 24DG -50-2345 -S	4244171
	COIL 24DN -50-2345 -S	4244172
	COIL 24DO -50-2345 -S	4250885
	COIL 96DG -50-2345 -S	4244173
	COIL 110AG -50-2345 -S	4244174
	COIL 205DG -50-2345 -S	4244275
	COIL 230AG -50-2345 -S	4244276
Seal kit for solenoid coil	Nut open, O-ring	4317299
	Nut with folding cap, O-ring	4317301
	Nut with cap, O-ring	4317302
Connector	Z4 standard 2-pole without PE	394287
	ZW4 incl. rectifier	394293
	Z4L incl. LED	394285
Manual overrides	M4 with knurled-head screw	4429328
	M5 with mushroom manual override (lockable)	4373722
	M6 with mushroom manual override (not lockable)	4373490

NOTE

The information in this brochure relates to the operating conditions and applications described. For applications not described, please contact the relevant technical department. All technical details are subject to change without notice.

4/2 and 4/3 directional spool valve solenoid-operated, direct-acting 4WE 6 A08

DESCRIPTION

HYDAC 4/2 and 4/3 directional spool valves of the 4WE 6 series are directional valves for oil-hydraulic systems which are used to open and close flow paths. The valve operates by oil-immersed solenoid. During this process, the solenoid pushes the valve's control spool into the position which will obtain the desired flow path.

FEATURES

- Direct-acting, solenoid-operated directional valve
- Interface according to DIN 24340 Form A6, ISO 4401-03
- Removable, high-performance solenoid coil, no need to open the hydraulic system during replacement
- Coil rotatable by 360°, allows flexible installation
- Electrical connection available in several versions
- With concealed manual override, additional versions available
- With reduced electrical power consumption



Nominal size 6
up to 60 l/min
up to 320 bar

CONTENTS

Description
Features
Model code
Spool types / symbols
Function
Section view
Technical data
Performance
Dimensions
Electrical connections
Manual overrides
Accessories

MODEL CODE

4WE 6 D - OF A08-24 D G /V /

Type

Solenoid-operated directional valve with 4 main ports, direct-acting

Nominal size

6

Spool symbol

See page 15

Version

Not specified = with return spring

-OF = without return spring, with detent (with D symbol only)¹⁾

Series

A08 = specified by the manufacturer

Rated voltage of the solenoid coil

24 = 24 VDC

Type of voltage

D = DC

Electrical connection (for details see page 19)

G = device connector, DIN EN 175301-803 A

O = device connector, M12

N = device connector, Deutsch

Sealing material

/N = NBR

/V = FKM

Manual override (for details, see page 19)

Not specified = with concealed manual override (standard)

/M1 = with manual override

/M2 = with covered manual override

/M4 = with knurled nut

/M5 = with mushroom head manual override (lockable)

/M6 = with mushroom head manual override (not lockable)

Orifice insert ¹⁾

Not stated = no orifice insert

/YXX : Y = port P, A, B, T

XX = diameter (e.g. 12 = 1.2 mm); preferred series: 0.8 mm, 1.0 mm, 1.2 mm

¹⁾ Other models on request

SPOOL TYPES / SYMBOLS

4/2-DIRECTIONAL SPOOL VALVES

Type	Basic symbol	With intermediate position
C		
D		
JA		
Y		

With return spring

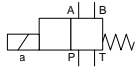

With detent (...-OF)

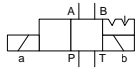

4/3-DIRECTIONAL SPOOL VALVES

Type	Basic symbol	With intermediate position
E		
G		
H		
J		
Q		

FUNCTION

The solenoid-operated directional spool valves of the 4WE 6 type are used to control nominal flow and consist of one valve casing (1) with an associated valve spool (2). Depending on the type, the valve is equipped with at least two return springs (3) and with one or two pole tubes (4) and solenoid coils (5) each.

The valve is hydraulically controlled by the actuation of the valve spool using solenoids (5). A solenoid is a converter which converts electrical energy into mechanical energy. The energised solenoid causes the oil-immersed magnetic spool to make a linear stroke movement. It uses the guide rod (6) to move the valve spool into the desired position. This causes the nominal flow directions between the respective connections to be released or closed. To obtain the valves' optimum switching capacity, the pressure-tight chamber of the pole tube should always be filled with oil.

The valve spool is pushed back into the starting position by the appropriate return spring after de-energisation of the solenoid.

The manual override (7) enables valve operation without energising the solenoid.

Without return spring with detent "OF"

This variant describes what is commonly called an impulse valve. This is a 4/2-directional valve with 2 solenoids and a detent. The detents are used to lock the valve spool in the respective switching position. There is no need to permanently energise the solenoid, which consequently contributes to energy-saving operation.

SECTION VIEW

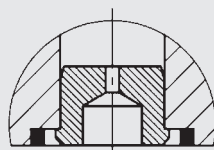
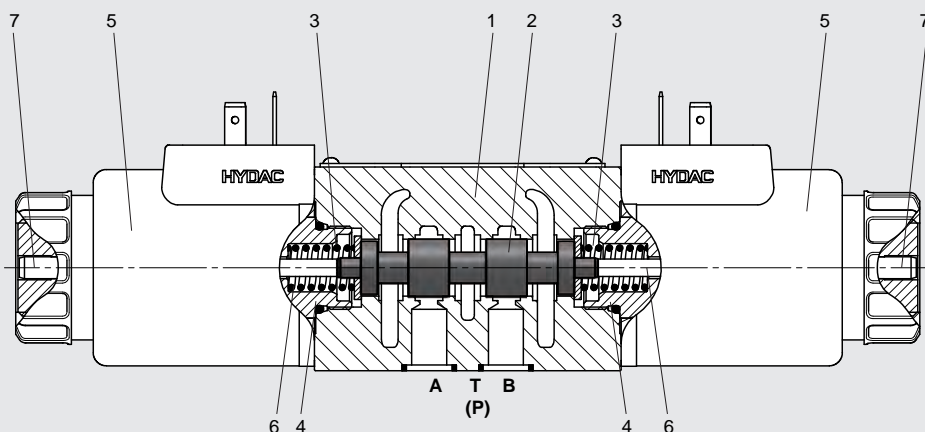

Orifice insert

Used to reduce nominal flows that are too high and outside of the valve's operating limits.

TECHNICAL DATA ¹

General specifications

MTTF _d :	According to EN ISO 13849-1:2015 Tables C1 & C2	
Ambient temperature range:	[°C]	-20 to +60
Installation position:	No orientation restrictions	
Weight:	[kg]	1.5 with one solenoid; 2.0 with two solenoids
Material:	Valve casing:	Cast iron
	Pole tube:	Steel
	Coil casing:	Steel
	Name plate:	Aluminium
Surface coating:	Valve casing:	Phosphate plated
	Pole tube:	Zn coating
	Coil casing:	ZnNi coating

Hydraulic specifications

Operating pressure:	[bar]	Port A, B, P: $p_{max} = 320$ Port T: $p_{max} = 210$
Nominal flow:	[l/min]	See performance limits on page 17
Operating fluid:	Hydraulic oil to DIN 51524 Part 1, 2 and 3	
Media operating temperature range:	[°C]	-20 to +80 (for standard sealing)
Viscosity range:	[mm ² /s]	15 to 400
Permitted contamination level of operating fluid:	Class 20/18/15 according to ISO 4406	
Max. switching frequency:	[1/h]	7,000
Manual override:	Up to approx. 50 bar tank pressure available	
Sealing material:	FKM, NBR	

Electrical specifications

Response time:	[ms]	Energised: approx. 50–200 De-energised: approx. 30–100
Type of voltage:	DC	
Rated voltage:	[V]	24
Voltage tolerance:	[%]	±10
Nominal power:	[W]	8.4
Duty cycle:	[%]	100
Max. surface temperature of the coil:	[°C]	150
Protection class according to DIN EN 60529:	With electrical connection "G"	IP65 ²
	With the electrical connection "O"	IP65 ²

¹ see "Conditions and Instructions for Valves" in brochure 53.000

² If installed correctly

PERFORMANCE

Pressure drop

measured at $v = 46 \text{ mm}^2/\text{s}$, $T = 40 \text{ }^\circ\text{C}$

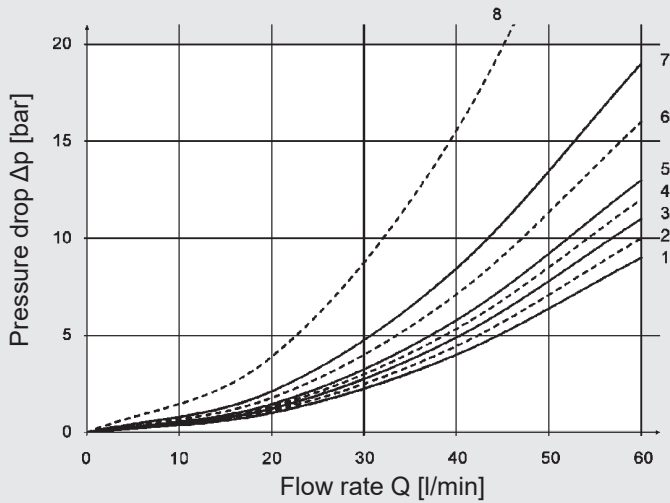

Performance limits

measured at $v = 46 \text{ mm}^2/\text{s}$, $T = 40 \text{ }^\circ\text{C}$

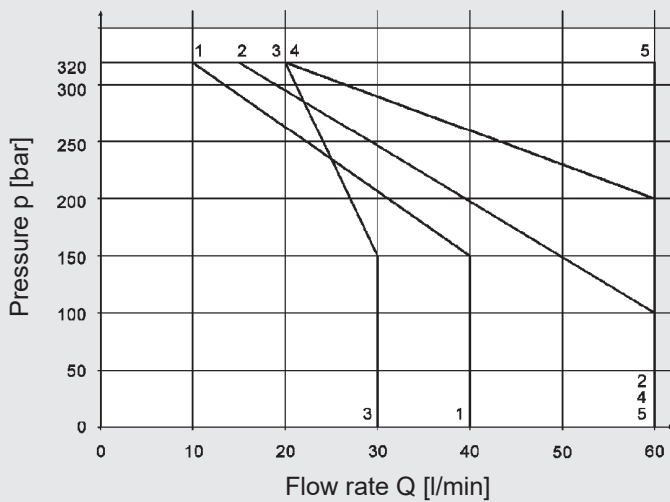

Performance assignment to the associated spools:

Spool	Pressure drop					Performance limits
	P→A	B→T	P→B	A→T	P→T	
C	1	2	3	4	-	5
D, D-OF, Y	1	2	3	4	-	1
E	5	5	5	5	-	4
G	8	8	8	8	6	3
H	4	4	4	4	7	5
J, JA	5	2	5	2	-	2
Q	5	5	5	5	-	2

The performance limits were determined with solenoids at operating temperature and 10% low voltage.

The specified performance limits are applicable for operation with two nominal flow directions. In the case of only one flow direction, the performance limits may be lower.

DIMENSIONS

Interface according to ISO 4401-03-02-0-05

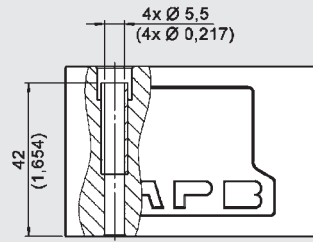
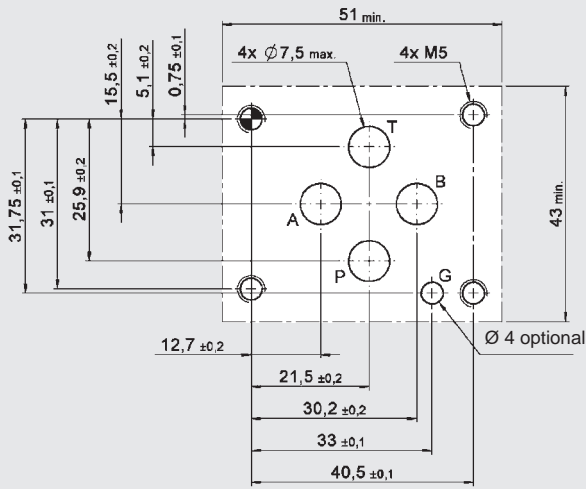

Clamping length

Mounting screws:

(not included in delivery)

DIN EN ISO 4762 – M5 x 50 – 10.9

Tightening torque: 7 Nm

With two solenoids

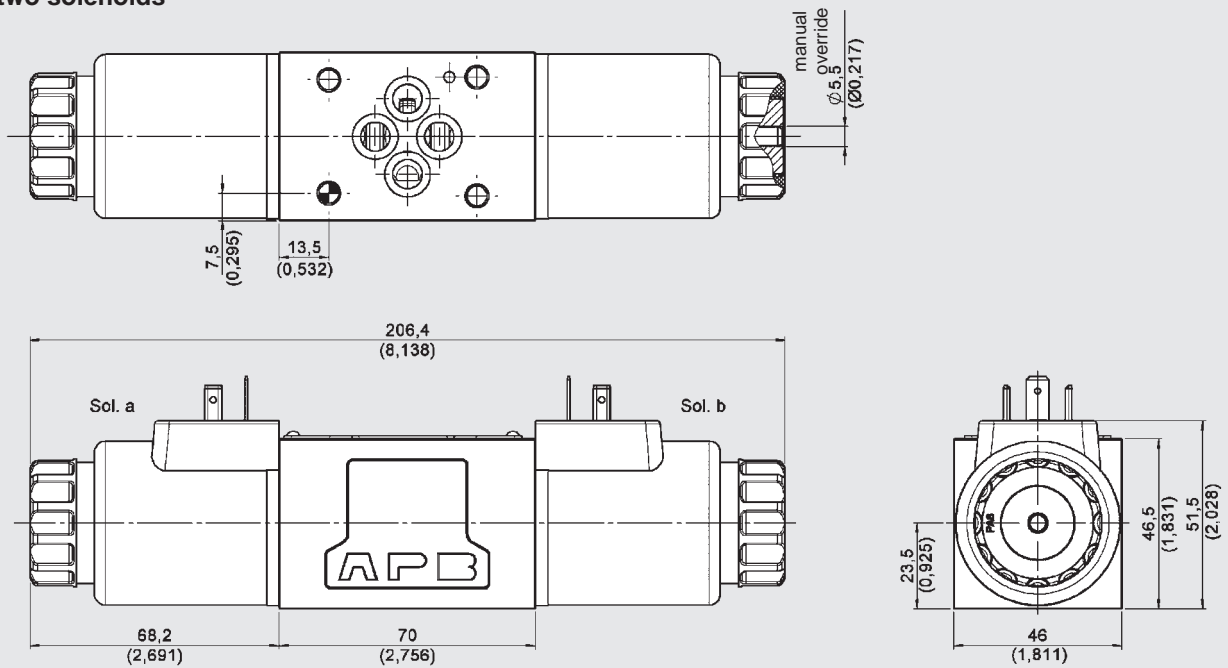

With one solenoid

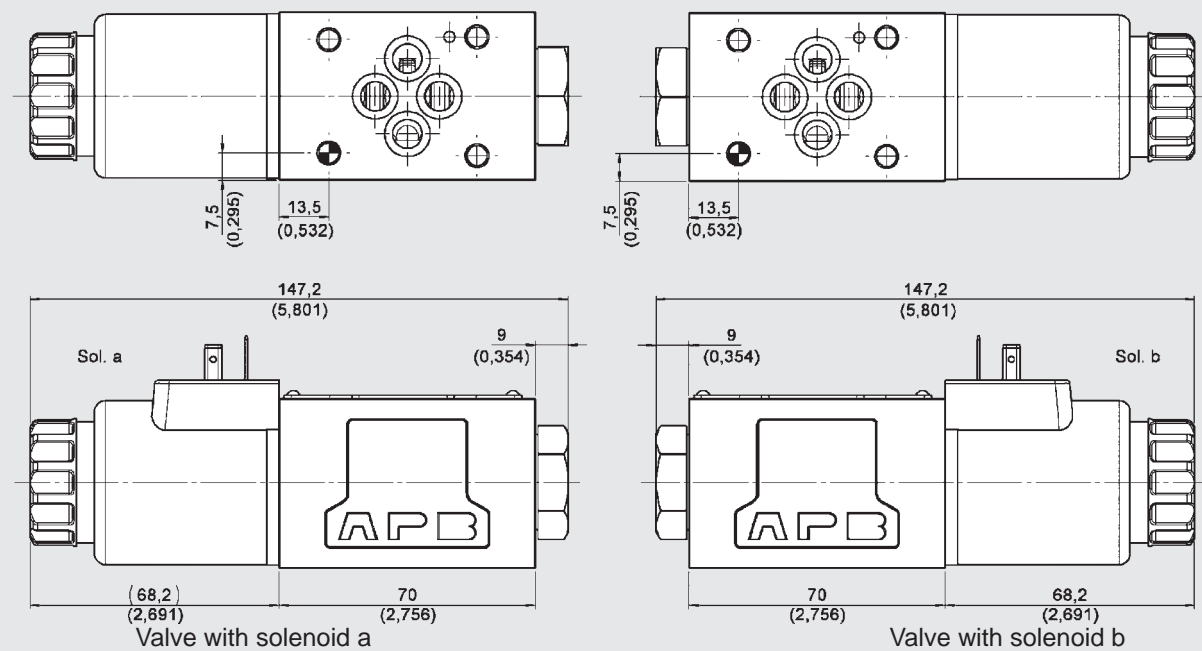

Valve with solenoid a

Valve with solenoid b

ELECTRICAL CONNECTIONS

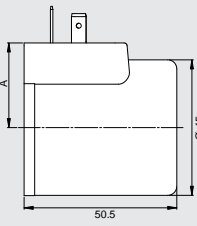
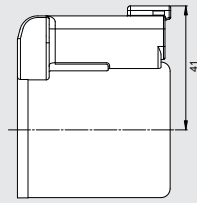
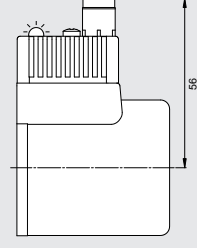
G Device connector DIN EN 175301-803 A		<ul style="list-style-type: none"> ● IP65 ● A = 28 mm for direct current (DC)
N Device connector, Deutsch (DT04-2P)		<ul style="list-style-type: none"> ● IP65 / IP67 ● Optional suppressor diode
O Device connector M12		<ul style="list-style-type: none"> ● IP65 ● With yellow LED as operation indicator ● Pin assignment

Other models on request

MANUAL OVERRIDES

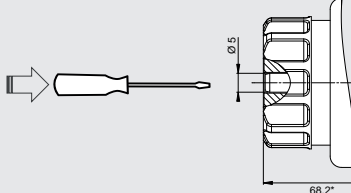
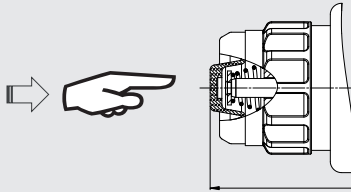
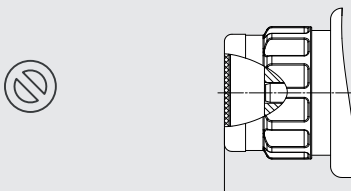
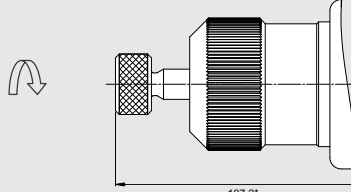
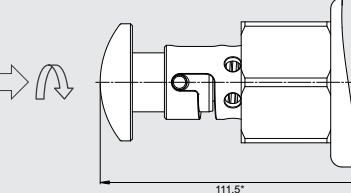
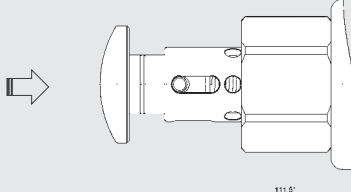
Standard with concealed manual override		Operation with tool
M1 with manual override		Operation without tool with spring return
M2 with covered manual override		Manual override covered, operation only possible after disassembly of cap
M4 with knurled- head screw		Operation by turning the knurled-head screw
M5 with mushroom button (lockable)		Operation by pressing, locking by subsequently turning the mushroom button
M6 with mushroom button (not lockable)		Operation by pressing the mushroom button

* Dimensions up to valve housing

The valve can also be operated manually. There are different forms of manual override available for this purpose.

The tank pressure should not exceed 50 bar. If the tank pressure is higher, the force required to operate the manual override increases accordingly.

For valves with two solenoids, simultaneous operation of both manual overrides is prohibited.

ACCESSORIES

	Designation	Part no.
Seal kits (4-part set)	9.25 x 1.78 80 Sh NBR	3492432
	9.25 x 1.78 80 Sh FKM	3120269
Mounting screws (4 pcs)	DIN EN ISO 4762 - M5 x 50 - 10.9	4312231
Solenoid coils	COIL 24DG -50-2345;8W -S	4277864
	COIL 24DN -50-2345;8W -S	4290983
	COIL 24DO -50-2345;8W -S	4250889
Seal kit for solenoid coil	Nut open, O-ring	4317299
	Nut with folding cap, O-ring	4317301
	Nut with cap, O-ring	4317302
Connector	Z4 standard 2-pole without PE	394287
	Z4L incl. LED	394285
Manual overrides	M4 with knurled-head screw	4429328
	M5 with mushroom manual override (lockable)	4373722
	M6 with mushroom manual override (not lockable)	4373490

Note

The information in this brochure relates to the operating conditions and applications described. For applications or operating conditions not described, please contact the relevant technical department.

All technical details are subject to change without notice.

4/2- and 4/3-directional spool valve solenoid-operated, direct-acting 4WE 10

DESCRIPTION

HYDAC 4/2- and 4/3-directional spool valves of the 4WE 10 series are directional valves for oil hydraulic systems which are used to open and close flow paths. The valve operates by oil-immersed solenoid. During this process, the solenoid pushes the valve's control spool into the respective position to obtain the desired flow path.

FEATURES

- Direct-acting, solenoid-operated directional valve
- Interface according to DIN 24340 Form A10, ISO 4401-05
- Removable high-performance solenoid coil, no need to open the hydraulic system during replacement
- Coil rotatable by 360°, allows flexible installation
- Electrical connection in several versions available
- With concealed manual override, additional versions available



Nominal size 10
up to 160 l/min
up to 350 bar

CONTENTS

Description
Features
Model code
Spool types / symbols
Function
Section view
Technical data
Performance
Dimensions
Electrical connections
Manual overrides
Accessories

MODEL CODE

4WE 10 D - OF A01-24 D G /V

Type

Solenoid-operated directional valve with 4 main ports, direct-acting

Nominal size

10

Piston symbol

See page 23

Version

Not specified = with return spring

-OF = without return spring, with detent (with D symbol only)

Series

A01 = specified by the manufacturer

Rated voltage of the solenoid coil¹⁾

12 = 12 VDC

24 = 24 VDC

96 = 96 VDC*

205 = 205 VDC*

* only in combination with the electrical connection G

Type of voltage

D = DC voltage

Electrical connection (for details see page 27)¹⁾

G = device plug, DIN EN 175301-803 A

N = device plug, Deutsch

N01 = device plug, Deutsch with suppressor diode

T = device plug, Junior Timer

Material of seal

/N = NBR

/V = FKM

Manual override (for details, see page 27)

Not specified = with concealed manual override (standard)

/M1 = with manual override

Orifice insert¹⁾

Not specified = no orifice insert

/YXX : Y = Port P, A, B or T

XX = diameter (e.g. 12 = 1.2 mm)

¹⁾ Other models on request

SPOOL TYPES / SYMBOLS

4/2-DIRECTIONAL SPOOL VALVES

Type	Basic symbol	With intermediate position
AE		
BE		
BJ		
C		
D		
EA		
EB		
GA		
GB		
HA		
HB		
JA		
JB		
QA		
UA		
Y		

With return spring

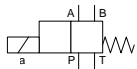

With detent (...-OF)

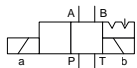

4/3-DIRECTIONAL SPOOL VALVES

Type	Basic symbol	With intermediate position
E		
F		
G		
H		
J		
L		
M		
P		
Q		
R		
U		

FUNCTION

The solenoid-operated directional spool valves of the 4WE 10 type are used to direct nominal flow and consist of one valve housing (1) with an associated valve spool (2). Depending on the type, the valve is equipped with at least two return springs (3) and with one or two pole tubes (4) and solenoid coils (5) each.

The hydraulic control of the valve is carried out through the actuation of the valve spool by the use of solenoids (5). A solenoid is a converter which converts electrical energy into mechanical energy. The energised solenoid causes the oil-immersed magnetic piston to make a linear stroke movement. It uses the guide rod (6) to move the valve spool into the desired position. This causes the nominal flow directions between the respective ports to be released or closed. To obtain the valves' optimum switching capacity, the pressure-tight chamber of the pole tube should always be filled with oil.

The valve spool is pushed back into the starting position by the appropriate return spring after de-energization of solenoid.

The manual override (7) enables valve operation without energising the solenoid.

Without return spring with detent "OF"

This alternative describes the so-called impulse valve. This is a 4/2-directional valve with 2 solenoids and detent. The detents are used to lock the valve spool in the respective switching position. There is no need to permanently energise the solenoids, which consequently contributes to energy-saving operation.

SECTION VIEW

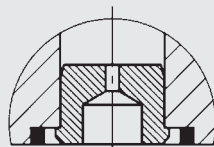
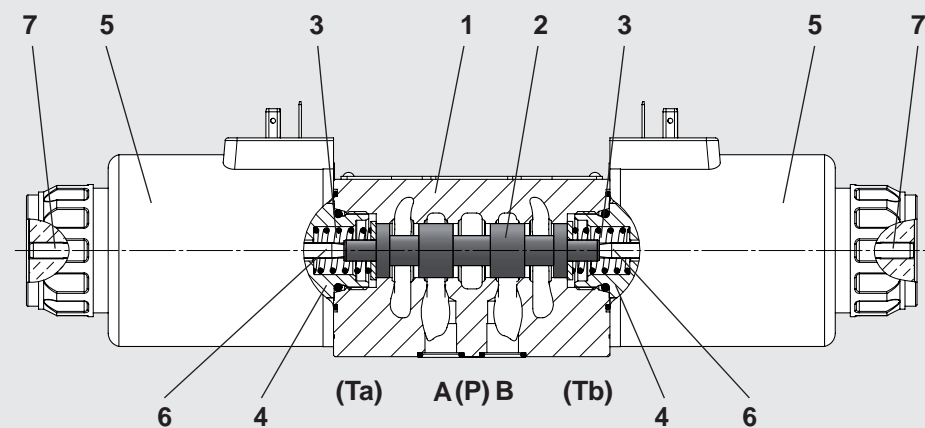

Orifice insert

Used to reduce nominal flows that are too high and outside of the valve's operating limits.

TECHNICAL DATA

General specifications			
MTTF _d :		According to EN ISO 13849-1:2015 Tables C1 & C2	
Ambient temperature range:	[°C]	-20 to +60	
Installation position:		No orientation restrictions	
Weight:	[kg]	4.0 with one solenoid; 6.0 with two solenoids	
Material:	Valve housing:	Cast iron	
	Pole tube:	Steel	
	Coil housing:	Steel	
	Name plate:	Aluminium	
Surface coating:	Valve housing:	Phosphate plated	
	Pole tube:	Zn-coating	
	Coil housing:	ZnNi-coating	
Hydraulic specifications			
Operating pressure:	[bar]	Port A, B, P:	$p_{max} = 350$
		Port T:	$p_{max} = 210$
Nominal flow:	[l/min]	See performance limits on page 25	
Operating fluid:		Hydraulic oil to DIN 51524 Part 1, 2 and 3	
Media operating temperature range:	[°C]	-20 to +80	
Viscosity range:	[mm ² /s]	10 to 500	
Permitted contamination level of operating fluid:		Class 20/18/15 according to ISO 4406	
Max. switching frequency:	[1/h]	15,000	
Manual override:		Up to approx. 50 bar tank pressure available	
Sealing material:		FKM, NBR	
Electrical specifications			
Switching time:	[ms]	Energised:	approx. 80 – 120
		De-energised:	approx. 70 – 110
Type of voltage:		DC	
Rated voltage:	[V]	12, 24, 96, 205	
Voltage tolerance:	[%]	±10	
Nominal power:	[W]	38	
Duty cycle:	[%]	100	
Max. surface temperature of the coil:	[°C]	150	
Degree of protection according to DIN EN 60529:	With electrical connection "G"	IP65 ²	
	With electrical connection "N"	IP65 / IP67 ²	
	With electrical connection "T"	IP65 ²	

¹ see "Conditions and Instructions for Valves" in brochure 53.000

² If installed correctly

PERFORMANCE

Pressure drop

measured at $v = 40 \text{ mm}^2/\text{s}$, $T = 43 \text{ }^\circ\text{C}$

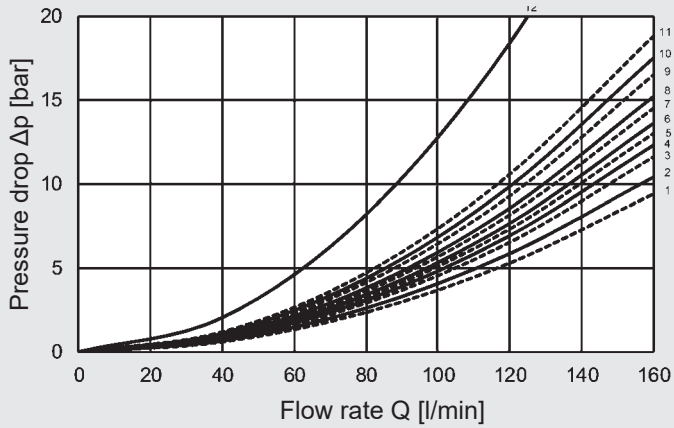

Performance limits

measured at $v = 40 \text{ mm}^2/\text{s}$, $T = 43 \text{ }^\circ\text{C}$

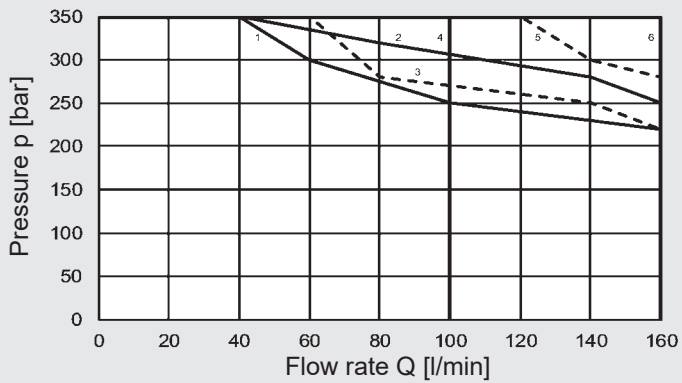

Performance assignment to the associated spools:

Spool	Pressure drop					Performance limits
	P→A	B→T	P→B	A→T	P→T	
AE	–	–	6	8	–	5
BE	4	8	–	–	–	6
BJ	4	3	–	–	–	3
C	9	8	5	5	–	6
D	9	11	8	8	–	6
D-OF	6	5	6	5	–	4
E, EA, EB	4	6	7	7	–	6
F	–	–	–	–	–	–
G, GA	9	10	9	11	12	–
H, HA, HB	1	5	2	7	11	6
J, JA, JB	4	2	7	3	–	6
L	4	7	4	2	–	2
M	2	9	2	9	–	6
P	–	–	–	–	–	–
Q, QA	4	7	6	7	–	5
R	5	–	9	7	–	1
U	4	3	4	7	–	2
Y	7	8	10	11	–	6

The performance limits were determined with solenoids at operating temperature and 10% low voltage.

The specified performance limits are applicable for operation with two directions of flow. The performance capacities may be lower when there is only one flow direction.

Restricted switching capacity for G96/G205 coils:

The max. permitted nominal flow specified in the diagram must be reduced by 10%. The switching times are extended.

DIMENSIONS

Interface according to ISO 4401-05-04-0-05

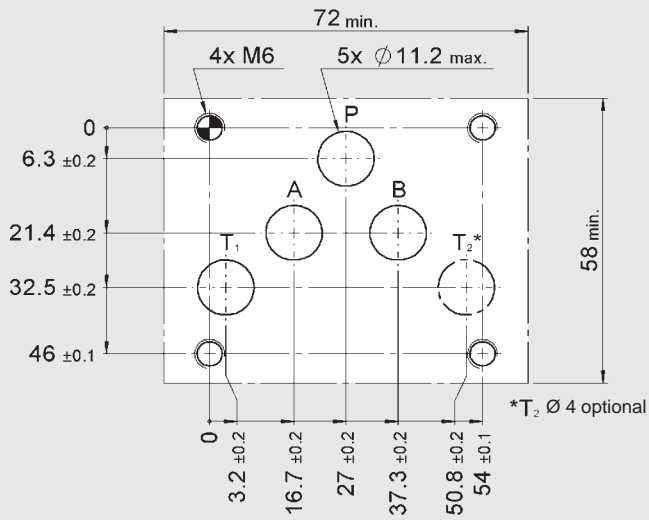

Mounting screws:
 (not included in delivery)
 DIN EN ISO 4762 – M6 x 40 – 10.9
 Tightening torque: 10 Nm

With two solenoids

Coil nut tightening torque
 6–7 Nm

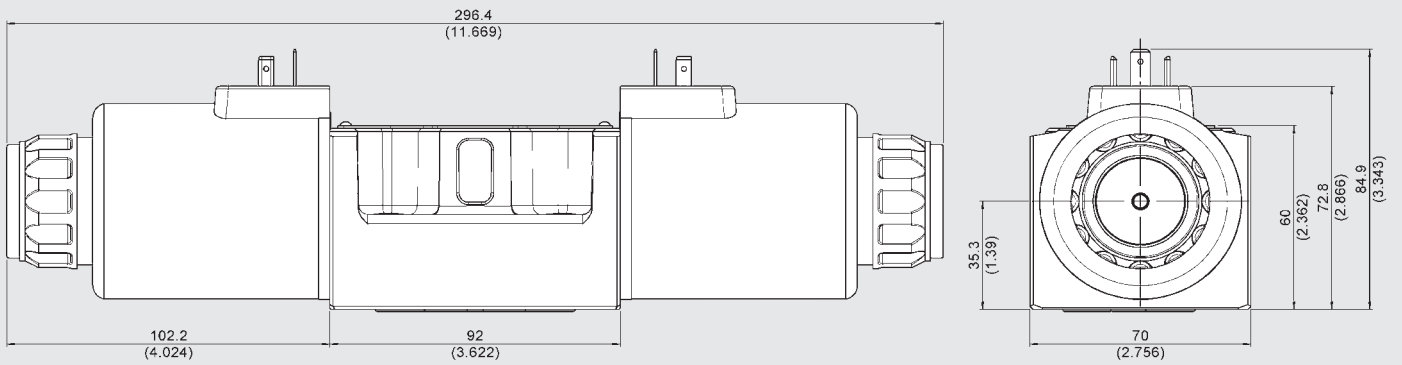
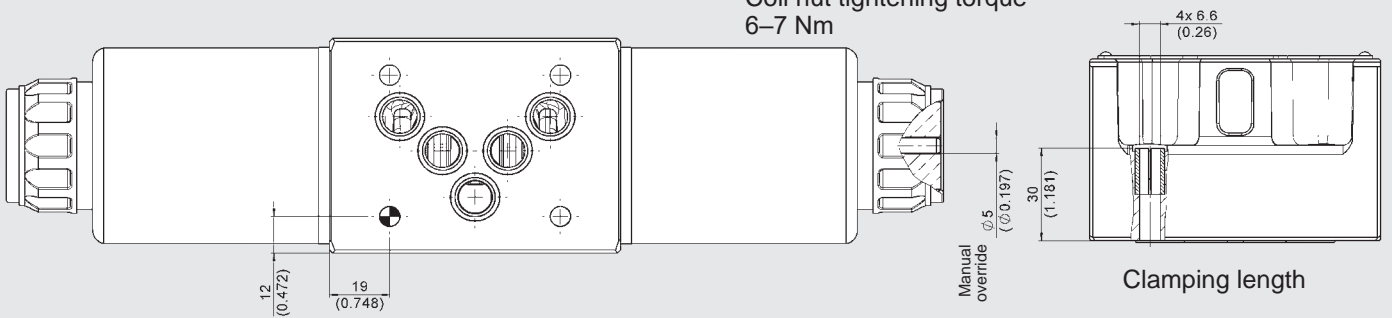

With one solenoid

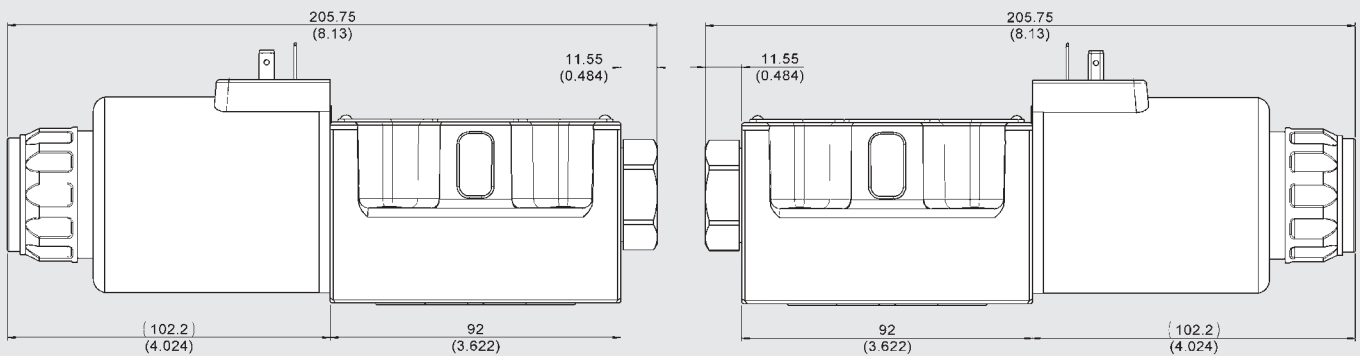

Valve with solenoid a

Valve with solenoid b

ELECTRICAL CONNECTIONS

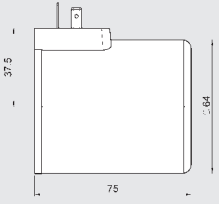
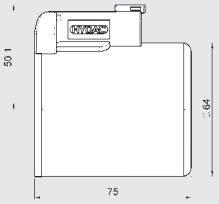
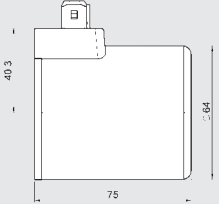
<p>G Device connector DIN EN 175301-803 A</p>		<ul style="list-style-type: none"> ● IP65
<p>N Device connector, Deutsch (DT04-2P)</p>		<ul style="list-style-type: none"> ● IP65 / IP67 ● Optional with suppressor diode
<p>T Device connector Junior Timer (radial)</p>		<ul style="list-style-type: none"> ● IP65 ● Optionally with suppressor diode

Other models on request

MANUAL OVERRIDES

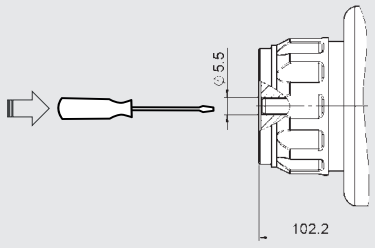
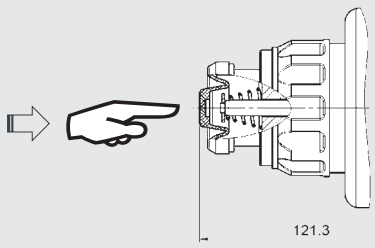
<p>Standard with concealed manual override</p>		<p>Operation with tool</p>
<p>M1 with manual override</p>		<p>Operation without tool with spring return</p>

* Dimensions up to valve housing

In case of emergency, the valve can also be operated manually. There are different forms of manual override available.

The tank pressure should not exceed 50 bar. If the tank pressure is higher, the force required to operate the manual override increases accordingly.

For valves with two solenoids, simultaneous operation of both manual overrides is prohibited.

ACCESSORIES

	Designation	Part no.
Seal kits (4-part set)	12,42 x 1,78-NBR -80Sh	4348706
	12,4 2x 1,78-FKM -80Sh	4348705
Mounting screws (4 pcs)	DIN EN ISO 4762 - M6 x 40 - 10.9	3524314
Solenoid coils	COIL 12DG -75-3164 38W	4251228
	COIL 24DG -75-3164 38W	4251230
	COIL 96DG -75-3164 38W	4251232
	COIL 110DG -75-3164 38W	4251233
	COIL 205DG -75-3164 38W	4251255
	COIL 220DG -75-3164 38W	4251257
Seal kit for solenoid coil	Nut open, O-ring	4348711
	Nut with folding cap, O-ring	4348713
Connector	Z4 standard 2-pole without PE	394287
	ZW4 incl. rectifier	394293
	Z4L incl. LED	394285

NOTE

The information in this brochure relates to the operating conditions and applications described. For applications not described, please contact the relevant technical department. All technical details are subject to change without notice.

4/2 and 4/3 directional spool valve solenoid-operated, direct-acting soft-shift 4WEW 10

DESCRIPTION

HYDAC 4/2 and 4/3 directional spool valves of the 4WEW 10 series are directional valves which are designed to open and close flow paths in oil-hydraulic systems. The valve operates by an oil-immersed solenoid. During this process, the solenoid pushes the valve's control spool into the position which will obtain the desired flow path.

An orifice in the magnetic spool and special valve spools with fine control grooves work together to dampen the movement and a soft shifting process.

FEATURES

- Direct-acting, solenoid-operated spool valve
- Interface according to DIN 24340 Form A10, ISO 4401-05
- Removable, high-performance solenoid coil, no need to open the hydraulic system during replacement
- Coil rotatable by 360°, allows flexible installation
- Electrical connection in several versions available
- Soft-shift process reduces shocks in hydraulic systems
- With concealed manual override, additional versions available

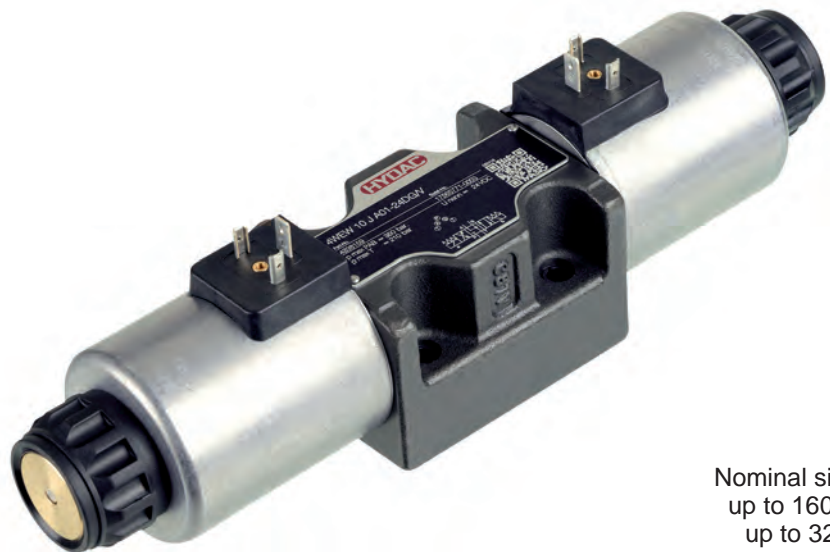

Nominal size 10
up to 160 l/min
up to 320 bar

CONTENTS

Description
Features
Model code
Spool types / symbols
Function
Section view
Technical data
Performance
Dimensions
Electrical connections
Manual overrides
Accessories

MODEL CODE

	4WEW	10	E	A01	-	24	D	G	/V
Type Solenoid-operated directional valve with 4 main ports, soft-shift									
Nominal size 10									
Spool symbol See page 31									
Series A01 = specified by the manufacturer									
Rated voltage of the solenoid coil¹⁾ 24 = 24 VDC * only in combination with the electrical connection G									
Type of voltage D = DC voltage									
Electrical connection (for details, see page 35) ¹⁾ G = device connector, DIN EN 175301-803 A									
Material of seal /N = NBR /V = FKM									
Manual override (for details, see page 35) Not specified = with concealed manual override (standard) /M1 = with manual override /M4 = with knurled nut									

¹⁾ Other models on request

SPOOL TYPES / SYMBOLS

4/2 DIRECTIONAL SPOOL VALVES

Type	Basic symbol	With intermediate position
D		
HA		
JA		

4/3 DIRECTIONAL SPOOL VALVES

Type	Basic symbol	With intermediate position
E		
H		
J		

FUNCTION

The solenoid-operated directional spool valves of the 4WEW 10 type are used to control nominal flow and consist of one valve casing (1) with an associated valve spool (2). Depending on the type, each valve is equipped with at least two return springs (3) and one or two pole tubes (4) and solenoid coils (5).

The valve is hydraulically controlled by solenoids (5) which operate the valve spool. A solenoid is a converter which converts electrical energy into mechanical energy. In this process, the energised solenoid causes the oil-immersed magnetic spool (6) to make a linear stroke movement. The solenoid uses the guide rod (7) to move the valve spool into the desired position. This causes the nominal flow directions between the respective ports to be released or closed.

An orifice in the magnetic spool and fine control grooves in the valve spool work together to slow down the switching process and lessen pressure drops. This significantly reduces shocks in the hydraulic system.

To obtain the valves' optimum switching capacity, the pole tube's pressure-tight chamber should always be vented and filled with oil.

If the solenoid has been de-energised, the valve spool is pushed back into the starting position by the appropriate return spring

The manual override (8) enables valve operation without energising the solenoid.

SECTION VIEW

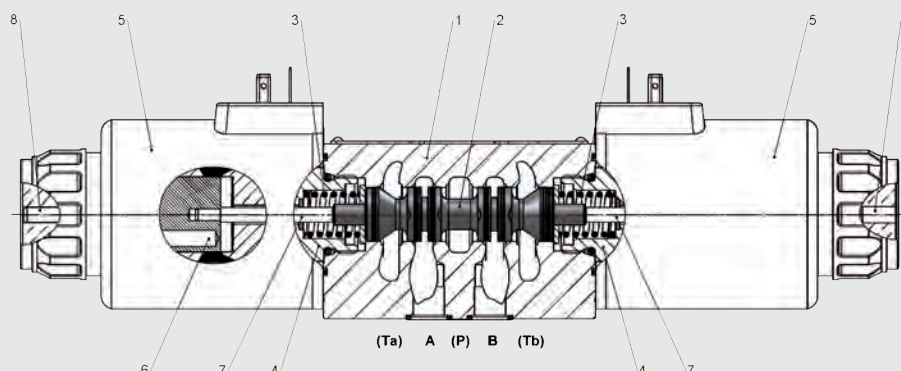

TECHNICAL DATA ¹

General specifications	
MTTF _d :	According to EN ISO 13849-1:2015 Tables C1 & C2
Ambient temperature range:	[°C] -20 to +60
Installation position:	No orientation restrictions
Weight:	[kg] 4.0 with one solenoid; 6.0 with two solenoids
Material:	Valve casing: Cast iron
	Pole tube: Steel
	Coil casing: Steel
	Name plate: Aluminium
Surface coating:	Valve casing: Phosphate plated
	Pole tube: Zn coating
	Coil casing: ZnNi coating
Hydraulic specifications	
Operating pressure:	[bar] Port A, B, P: $p_{max} = 320$ Port T: $p_{max} = 210$
Nominal flow:	[l/min] See performance limits on page 33
Operating fluid:	Hydraulic oil to DIN 51524 Part 1, 2 and 3
Media operating temperature range:	[°C] -20 to +80
Viscosity range:	[mm ² /s] 15 to 400
Permitted contamination level of operating fluid:	Class 20/18/15 according to ISO 4406
Max. switching frequency:	[1/h] 7,000
Manual override:	Up to approx. 50 bar tank pressure available
Sealing material:	FKM (standard), NBR
Electrical specifications	
Response time:	[ms] Response times highly dependent on viscosity, pressure and application (see sample curves, page 33)
Type of voltage:	DC
Rated voltage:	[V] 24
Voltage tolerance:	[%] ± 10
Nominal power:	[W] 38
Duty cycle:	[%] 100
Max. surface temperature of the coil:	[°C] 150
Protection class according to DIN EN 60529:	With electrical connection "G" IP65 ²

¹ see "Conditions and Instructions for Valves" in brochure 53.000

² If installed correctly

PERFORMANCE

Pressure drop

measured at $v = 46 \text{ mm}^2/\text{s}$, $T = 40 \text{ }^\circ\text{C}$

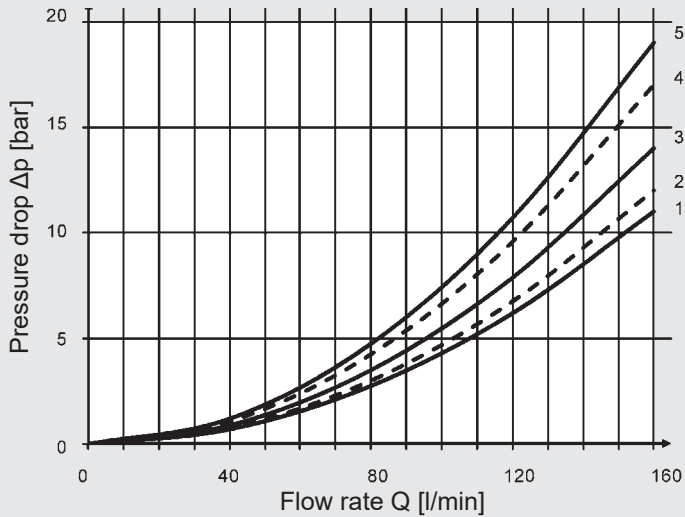

Performance limits

measured at $v = 46 \text{ mm}^2/\text{s}$, $T = 40 \text{ }^\circ\text{C}$

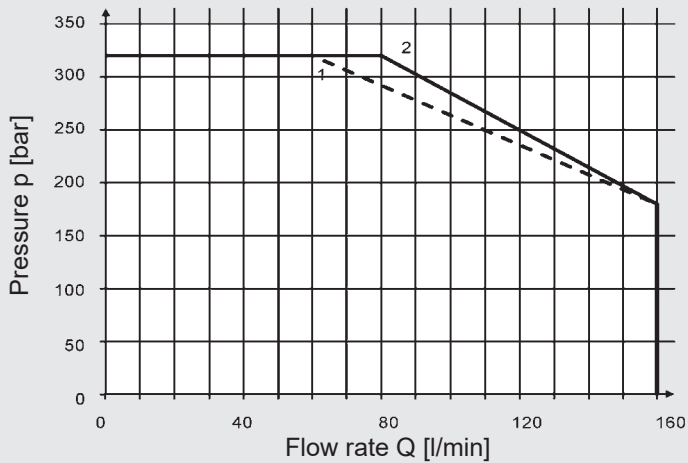

Sample curves

Measured with flow from both sides
(e.g. $P \rightarrow A$ and $B \rightarrow T$)

Measured at symbol E at $v = 46 \text{ mm}^2/\text{s}$, $T = 40 \text{ }^\circ\text{C}$

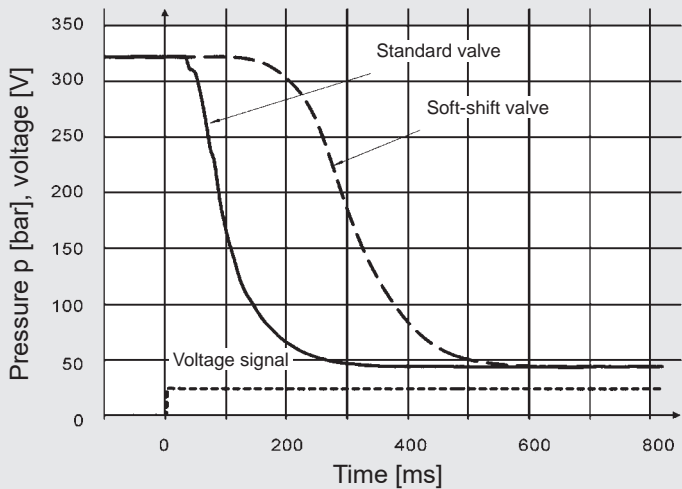

Performance assignment to the associated spools:

Spool	Pressure drop					Performance limits
	P→A	B→T	P→B	A→T	P→T	
D	4	4	4	4	–	2
E	3	3	3	3	–	1
H, HA	1	3	1	3	5	2
J, JA	3	2	3	2	–	1

The performance limits were calculated with solenoids at operating temperature and 10% low voltage.

The specified performance limits are applicable for operation with two nominal flow directions.

If there is only one nominal flow direction, the power limits may be lower.

DIMENSIONS

With two solenoids

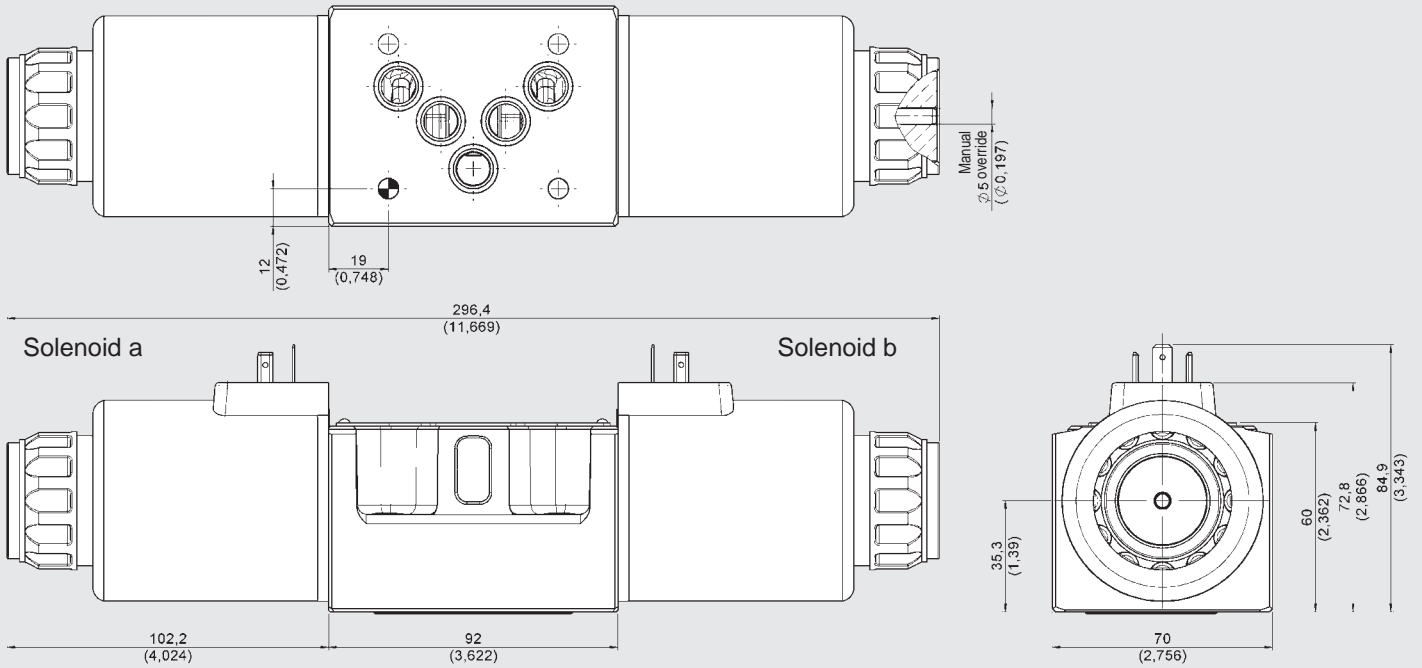

With one solenoid

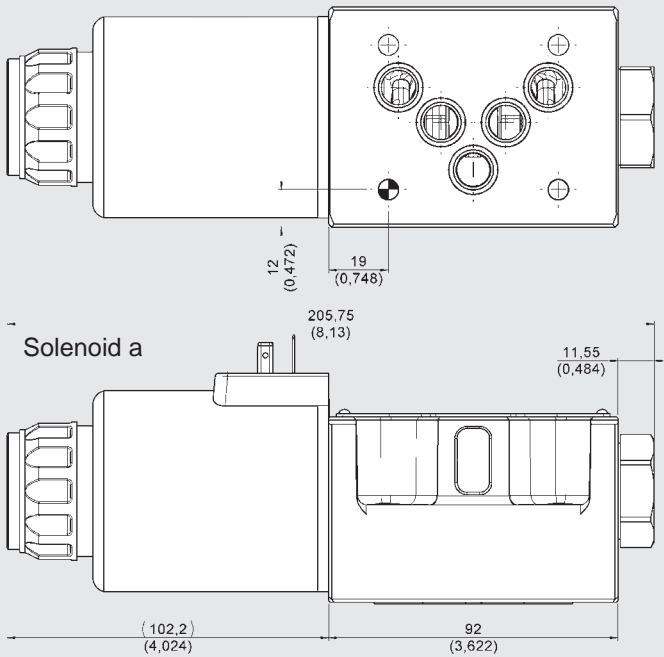

Interface

ISO 4401-05-04-0-05 (CETOP 5)

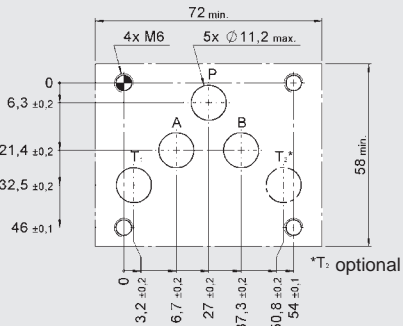

Clamping length

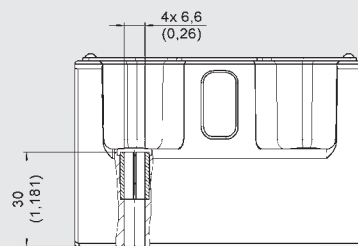

Mounting screws:

(not included in delivery)

DIN EN ISO 4762 – M6 x 40 – 10.9

Tightening torque: 10 Nm

ELECTRICAL CONNECTIONS

G
Device
connector
DIN EN
175301-803 A

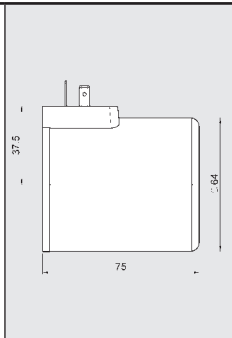

● IP65

Other models on request

MANUAL OVERRIDES

Standard
with
concealed
manual
override

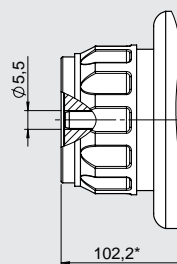

Operation
with tool

M4
with
knurled-
head
screw

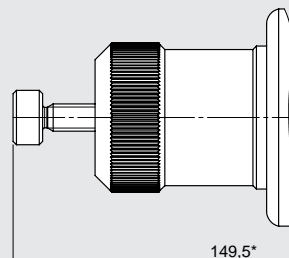

Operation by
turning the
knurled-head
screw

* Dimensions up to valve casing

The valve can also be operated manually. There are 2 manual overrides available for this purpose.

The tank pressure should not exceed 50 bar. If the tank pressure is higher, the force required to operate the manual override increases accordingly.

For valves with two solenoids, simultaneous operation of both manual overrides is prohibited.

ACCESSORIES

	Designation	Part no.
Seal kits (4-part set)	12.42 x 1.78-NBR -80Sh	4348706
	12.4 2x 1.78-FKM -80Sh	4348705
Mounting screws (4 pcs)	DIN EN ISO 4762 - M6 x 40 - 10.9	3524314
Solenoid coils	COIL 24DG -75-3164 38W	4251230
Seal kit for solenoid coil	Nut open, O-ring	4348711
	Z4 standard 2-pole without PE	394287
Connector	ZW4 incl. rectifier	394293
	Z4L incl. LED	394285

Note

The information in this brochure relates to the operating conditions and applications described. For applications not described, please contact the relevant technical department. All technical details are subject to change without notice.

2/2, 3/2, 3/3, 3/4, 4/2, 4/3 and 4/4 Directional Poppet Valve solenoid-operated, direct-acting WSE 6

DESCRIPTION

HYDAC 2/2, 3/2, 3/3, 3/4, 4/2, 4/3 and 4/4 directional poppet valves of WSE 6 series were directional valves for oil hydraulic systems, which are used to open and close flow paths. The valve operates by oil-immersed solenoid. During this process, the solenoid pushes the valve's control spool into the respective position to obtain the desired flow path.

FEATURES

- Patented function principle
- Pressure-equalised design
- Seat-tight closing
- Hardened poppet-seat elements (piston)
- Interface according to DIN 24340 Form A6, ISO 4401-03
- Removable high-performance solenoid coil, no need to open the hydraulic system during replacement



Nominal size 6
up to 25 l/min
up to 350 bar

CONTENTS

Description

Features

Model code

Spool types / symbols

Function

Section view

Technical data

Performance

Dimensions

Electrical connections

Manual overrides

Accessories

MODEL CODE

	4	WSE	6	E	H01	-	24	D	G	/V	/L	/L
Ports 2, 3 or 4												
Type Directional poppet valve, direct-acting												
Nominal size 6												
Spool symbol See page 39												
Series H01 = specified by the manufacturer												
Rated voltage of the solenoid coil ¹⁾ 24 = 24 V DC												
Type of voltage D = DC voltage												
Electrical connection (for details, see page 43) G = device connector, DIN EN 175301-803 L = single leads L02 = single leads with suppressor diode N = device connector, Deutsch N01 = device connector, Deutsch with suppressor diode O = device connector, M12 U = device connector, Junior Timer U01 = device connector, Junior Timer with suppressor diode												
Sealing material ¹⁾ /V = FKM (standard)												
Manual override Not specified = with concealed manual override (standard) /M2 = with covered manual override												
Orifice insert Not specified = no orifice insert /YXX : Y = port P, A, B, T XX = diameter (e.g. 14 = 1.4 mm) preferred series: 0.5 mm; 0.7 mm; 1 mm; 1.4 mm; 2 mm												
Check valve Not specified = no check valve /RV = check valve in port P with a cracking pressure of 0.6 bar												

¹⁾ Other models on request

SPOOL TYPES / SYMBOLS

2/2-DIRECTIONAL POPPET VALVES

Type	Symbol
E2	
BE2	
E4	
BE4	

3/2-, 3/3- AND 3/4-DIRECTIONAL POPPET VALVES

Type	Symbol
X	
C	
E	
E+H	

4/2-, 4/3- AND 4/4-DIRECTIONAL POPPET VALVES

Type	Symbol
X	
C	
E	
H	
E+H	
J+M	
J+M-2RV	
M+J-2RV	
Z+X-2RV	

FUNCTION

The solenoid-operated directional poppet valves of type WSE 6 are used to control a flow. The valve design is patented and consists of a valve casing (1) and depending on the type, one or more poppet-seat elements (2). Depending on the type, the valve is equipped with one or more return springs (3) and with one or two pole tubes (4) and solenoid coils (5) each. The hydraulic control of the valve is carried out through the actuation of the valve spool by the use of solenoids (5).

A solenoid is a converter, which converts electrical energy into mechanical energy. The energized solenoid causes the oil-immersed magnetic piston to make a linear stroke movement. It uses the guide rod (6) to move the poppet-seat elements into the desired position. This causes the nominal flow directions between the respective ports to be released or seat-tight closed.

The modular principle of the key components enables a large variety of switching configurations. Consequently these valves can be used as a leak-free alternative to spool valves. The special grounded poppet-seat elements are pressure-equalised and with it double-tight, i.e. pressure reversals (within the permitted port pressures) do not result in undesired opening.

To obtain the valves' optimum switching capacity, the pressure-tight chamber of the pole tube should always be filled with oil. The poppet-seat element is pushed back into the starting position by the appropriate return spring after de-energization of solenoid.

The manual override (7) enables valve operation without energising the solenoid.

SECTION VIEW

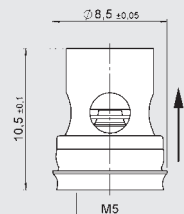
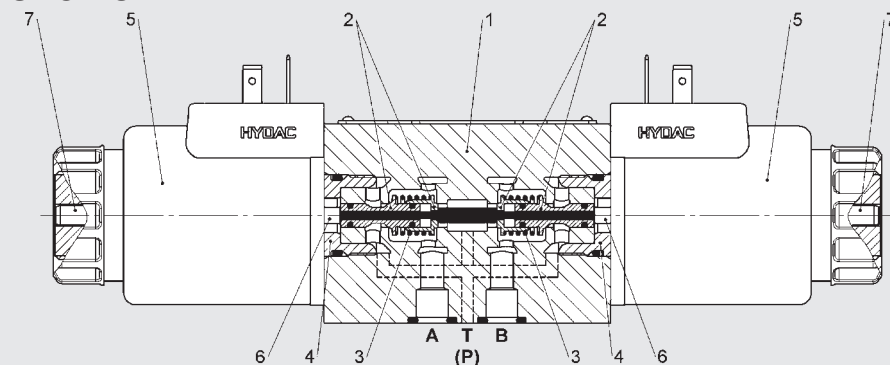

Non-return valve

Closes port P to prevent reverse oil flow.

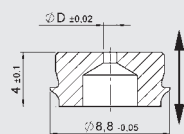

Orifice insert

Used to reduce nominal flows that are too high and outside of the valve's operating limits.

TECHNICAL DATA ¹⁾

General performance data

MTTF _d :	According to EN ISO 13849-1:2016 Table C1	
Ambient temperature:	[°C]	-20 to +60
Installation position:	No orientation restrictions	
Weight:	[kg]	1.7 with one solenoid; 2.2 with two solenoids
Material:	Valve casing:	Steel
	Pole tube:	Steel
	Coil casing:	Steel
	Name plate:	Aluminium
Surface coating:	Valve casing:	Phosphate plated
	Pole tube:	Zn-coating
	Coil casing:	ZnNi-coating

Hydraulic specifications

Operating pressure:	[bar]	Port A, B, P: $p_{\max} = 350$ Port T: $p_{\max} = 70$
Nominal flow:	[l/min]	25
Operating fluid:	Hydraulic oil to DIN 51524 Part 1, 2 and 3	
Media operating temperature range:	[°C]	-20 to +80
Viscosity range:	[mm ² /s]	10 to 500
Permitted contamination level of operating fluid:	Class 20/18/15 according to ISO 4406	
Max. switching frequency:	[1/h]	3,600
Manual override:	Up to approx. 50 bar tank pressure available	
Sealing material:	FKM	

Electrical specifications

Switching time:	[ms]	See table, page 41
Type of voltage:	DC	
Rated voltage:	[V]	24
Voltage tolerance:	[%]	±10
Nominal power:	[W]	30
Duty cycle:	[%]	100
Max. surface temperature of the coil:	[°C]	150
Protection class according to DIN EN 60529:	with electrical connection "G" IP65 ²⁾	

¹⁾ see "Conditions and Instructions for Valves" in brochure 53.000

²⁾ if installed correctly

PERFORMANCE

Pressure drop

measured at $v = 30 \text{ mm}^2/\text{s}$

$T = 45 \text{ }^\circ\text{C}$

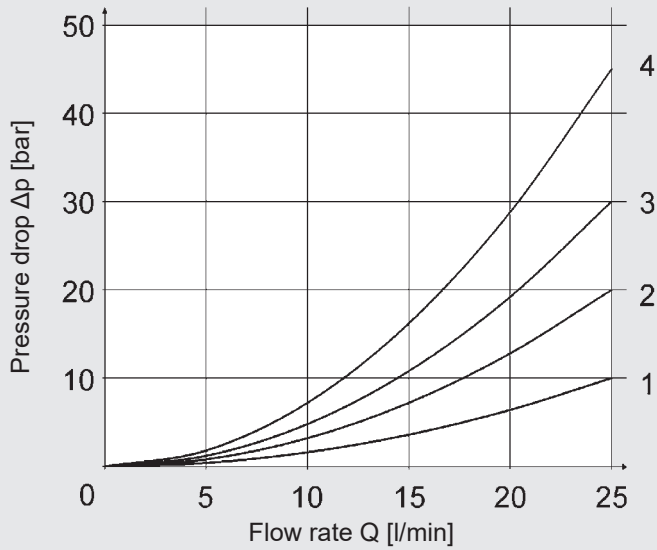

Performance limits

Switch-on current $I_{\text{ON}} \leq 0.7 \times I_N$

Switch-off current $I_{\text{OFF}} \geq 0.07 \times I_N$

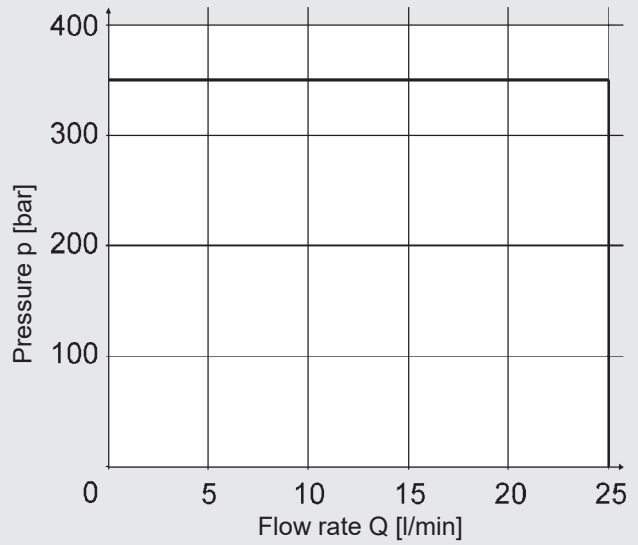

Performance assignment to the associated spools:

Ports	Symbol	Pressure drop												Switching times			
		a				b				0 (+)				On [ms]		Off [ms]	
		P-A	P-B	A-T	B-T	P-T	P-A	P-B	A-T	P-A	B-T	P-B	A-T	P-T	0.7 x I _N		1.0 x I _N
2	E2	2													110	45	25
2	BE2								1						110	45	25
2	E4					2									60	40	25
2	BE4												1		60	40	25
3	X	2											1		60	40	25
3	C			2					1						110	45	25
3	E	2						1							60	40	25
3	E+H	2						1	(2)			(1)	(3)		60	40	25
4	X	2			1						2	1			110	45	25
4	C						2	1	2	1					110	45	25
4	E	2			1			2	1						90	45	25
4	H	2			1			2	1	3	3	3	3	2	60	40	25
4	E+H	2			1			2	1	(2)	(1)	(2)	(1)	(1)	90	45	25
4	J+M	2			1			2	1	(2)	1	(2)	1		60	40	25
4	J+M-2RV	4			1			4	1	(2)	1	(4)	1		60	40	25
4	M+J-2RV	4			1			4		(1)	4	(1)			110	45	25
4	Z+X-2RV			2	1		3	4		3	1	(4)	(2)		110 (a) 60 (b)	45 (a) 40 (b)	25

The performance limits were determined with solenoids at operating temperature and 10% low voltage.

The specified performance limits are applicable for operation with two directions of flow. The performance capacities may be lower when there is only one flow direction.

DIMENSIONS

With one solenoid
2/2, 3/2

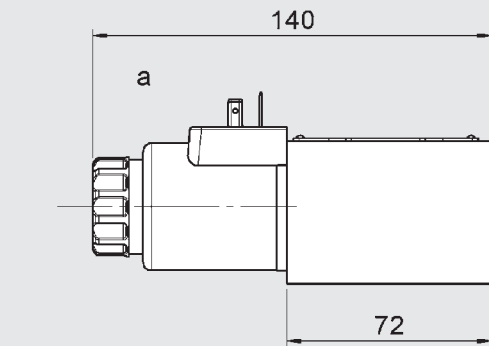
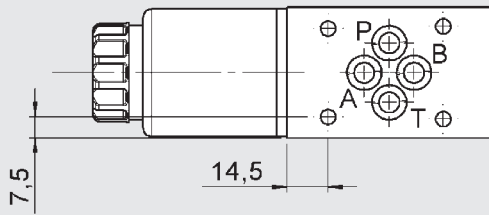

Side view

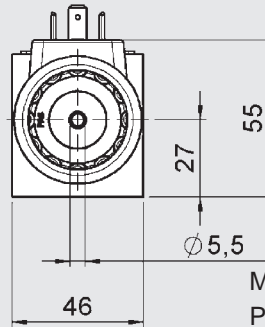

Clamping length
to ISO 7790

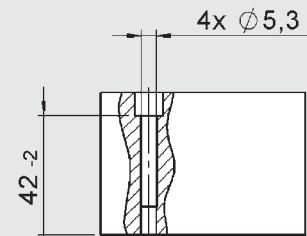

Manual override
Push pin

With one solenoid
4/2

Type 4/2-X

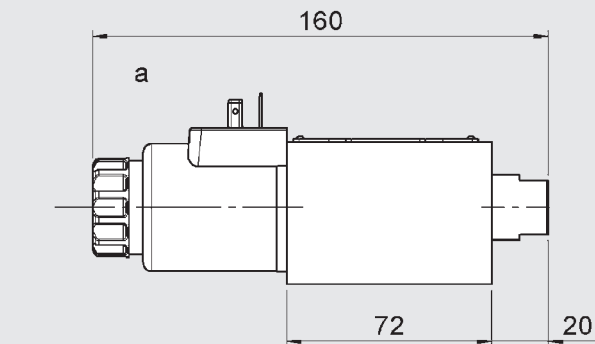
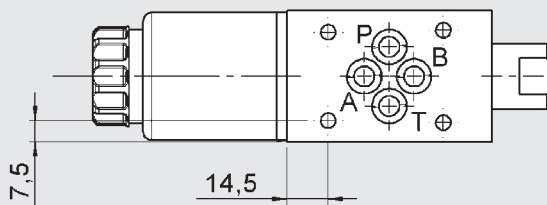

Type 4/2-C

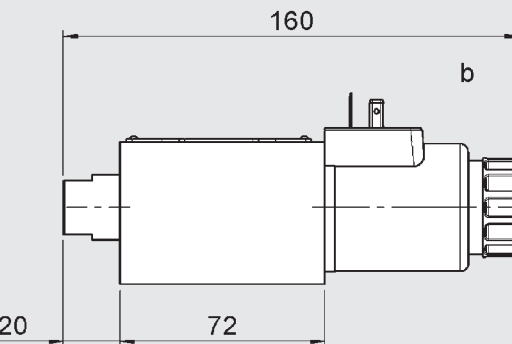
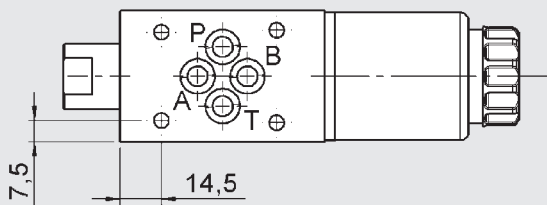

With two solenoids
3/3, 3/4, 4/3, 4/4

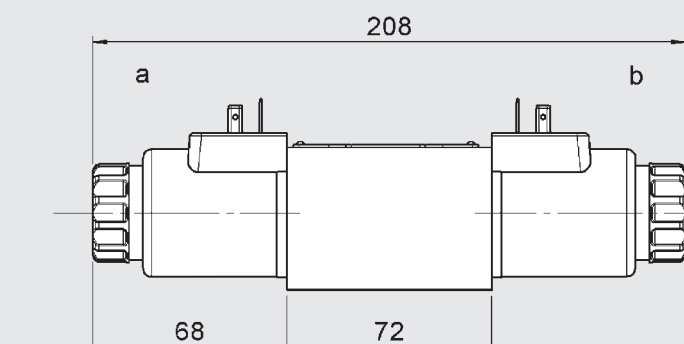
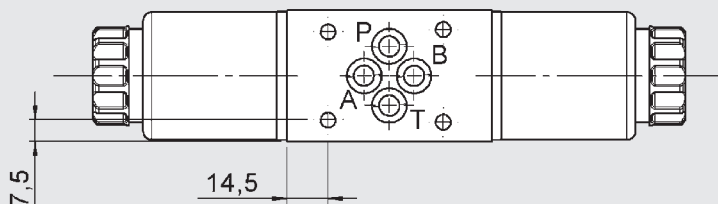

Interface according to ISO 4401-03-02-0-05 (CETOP 3)

Mounting screws:

(not included in delivery)

DIN EN ISO 4762 – M5 x 50 – 10.9

Tightening torque: 6 Nm - 7 Nm

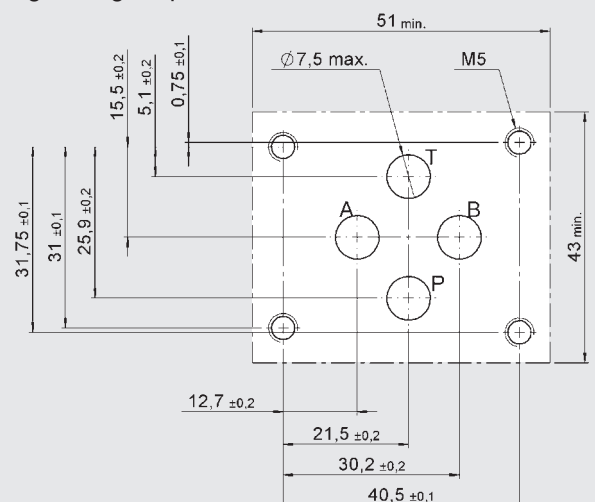

ELECTRICAL CONNECTIONS

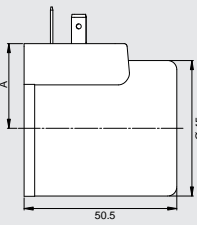
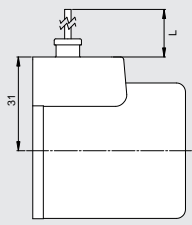
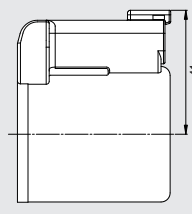
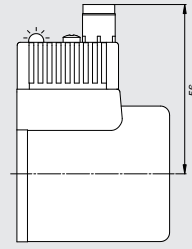
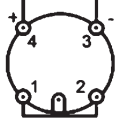
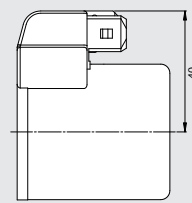
G Device connector DIN EN 175301-803 A		<ul style="list-style-type: none"> ● IP65 ● A = 28 mm for DC (DG)
L 2 strands		<ul style="list-style-type: none"> ● IP65 ● Standard strands length L = 457 mm ● Optional with suppressor diode
N Device connector, Deutsch (DT04-2P)		<ul style="list-style-type: none"> ● IP65 / IP67 ● Optional with suppressor diode
O Device connector M12		<ul style="list-style-type: none"> ● IP65 ● With yellow LED as operation indicator ● Pin assignment 
U Device connector Junior Timer (axial)		<ul style="list-style-type: none"> ● IP65 ● Optional with suppressor diode

Other models on request

MANUAL OVERRIDES

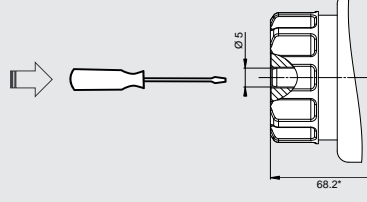
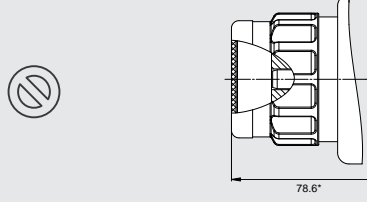
Standard with concealed manual override		Operation with tool
M2 with covered manual override		Manual override covered, operation only possible after disassembly of cap

* Dimensions up to valve casing

In case of emergency, the valve can also be operated manually. There are different forms of manual override available.

The tank pressure should not exceed 50 bar. If the tank pressure is higher, the force required to operate the manual override increases accordingly.

For valves with two solenoids, simultaneous operation of both manual overrides is not permitted (with the exception of valves with four switching positions).

ACCESSORIES

	Designation	Part no.
Seal kits (4-part set)	9.25 x 1.78 80 Sh FKM	3120269
Mounting screws (4 pcs)	DIN EN ISO 4762 - M5 x 50 - 10.9	4312231
Solenoid coils	COIL 24DG -50-2345 -S	4244171
	COIL 24DN -50-2345 -S	4244172
	COIL 24DO -50-2345 -S	4250885
	COIL 24DU -50-2345 -S	4250892
Seal kit for solenoid coil	Nut open, O-ring	4317299
	Nut with cap, O-ring	4317302
Connector	Z4 standard 2-pole without PE	394287
	Z4L incl. LED	394285
Orifice insert	Orifice for WSE 6 H01	4371106
Check valve	NRV for WSE 6 H01	4371006

Note

The information in this brochure relates to the operating conditions and applications described. For applications not described, please contact the relevant technical department. All technical details are subject to change without notice.

2/2- and 3/2- directional poppet valve with switch position monitoring solenoid-operated, direct-acting WSER 6

DESCRIPTION

HYDAC 2/2- and 3/2- directional poppet valves of the WSER 6 series are directional valves with switch position monitoring for processing signals in safety controls. These valves close leakage-free due to their seat tight design.

Depending on the version, either the initial position (0) or the switched position (A) or both positions (0, A) can be detected. The poppet elements have an overlap range caused by applying the electrical switching signal just before reaching the end position. This ensures that the potential flow at the switch points close to the seat is reduced to a minimum.

FEATURES

- Patented function principle
- Pressure-compensated construction
- Seat tight closing
- Hardened poppet elements
- Interface according to DIN 24340 Form A6, ISO 4401-03
- Removable high-performance solenoid coil, no need to open the hydraulic system during replacement
- With integrated sensor to monitor the switching position



Nominal size 6
up to 12 l/min
up to 350 bar

CONTENTS

Description
Features
Model code
Spool types / symbols
Monitored switching position
Function
Section view
Technical data
Performance
Switching logic
Sensor diagrams
Dimensions
Electrical connections
Manual overrides
Accessories

MODEL CODE

3 WSE R0 6 D H01 - 24 DG /V / /

Ports

2 or 3

Type

Directional poppet valve, direct acting

Monitored position

See "Monitored positions" on page 47

Nominal size

6

Symbol ¹

See "Symbols" on page 47

Series

H01 = specified by manufacturer

Nominal voltage ¹

24 = 24 V DC

Connector types ¹

DG = DIN connector type A according to EN 175301-803

Sealing material ¹

V = FKM (standard)

Orifice insert

Not specified = no orifice insert

/YXX : Y = P, A, B, T = port

XX = diameter (e.g. 14 = 1.4 mm)

preferred series: 0.5 mm; 0.7 mm; 1 mm; 1.4 mm; 2 mm

Check valve

Not specified = no check valve

/RV = check valve in port P with a cracking pressure of 0.6 bar

¹⁾ Other models on request

SPOOL TYPES / SYMBOLS

2/2-DIRECTIONAL POPPET VALVES

Type	Basic symbol	With intermediate position
E2		
BE2		
E4		
BE4		

3/2-DIRECTIONAL POPPET VALVES

Type	Basic symbol	With intermediate position
D		
Y		

MONITORED SWITCHING POSITION

Sensor	Type	Symbol	Description
Sensor for one switching position	R0		Monitoring of initial position
Sensor for one switching position	RA		Monitoring of the switched position
Sensor for both switching positions	R0A		Monitoring of the initial and switched position

FUNCTION

The solenoid-operated directional poppet valves of the WSER 6 series are used to control a flow.

The valve consists of a valve casing (1) and a poppet element (2) that can be moved linearly between two seats or end positions. The valve moves into switched position A caused by energization of the coil (5), which pushes the solenoid anchor guided into pole tube (4) to the poppet element via guide rod (6). Thereby the flow directions between the respective ports are released or seat tight closed. If the coil has been switched off, the poppet element of the return spring (3) is shifted back into initial position 0. The switching position is recorded by sensor rod (7) of the position sensor (8). This sensor rod is permanently mechanically fixed to the poppet element.

If de-energised, the valve can be switched by the manual override (9).

SECTION VIEW

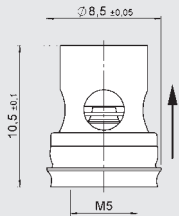
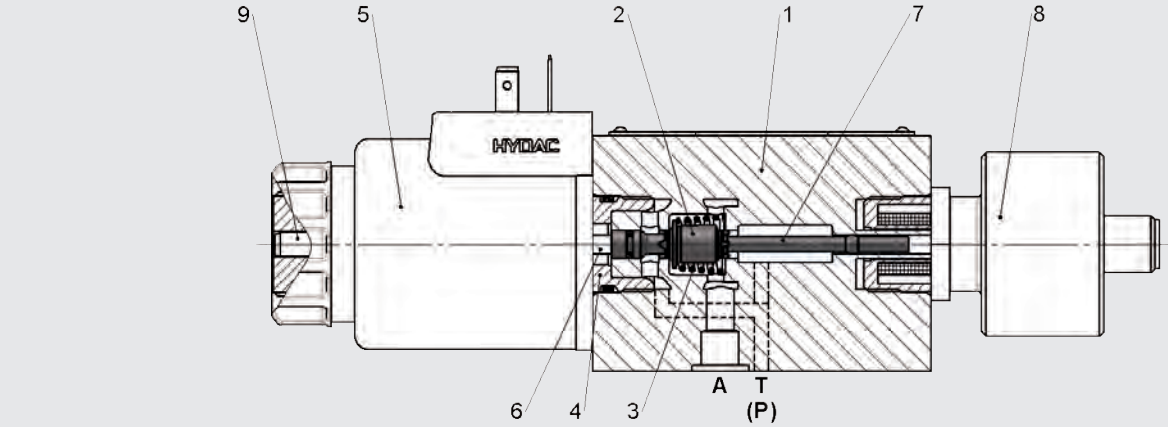

Check valve

Closes up port P to prevent reverse oil flow.

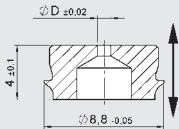

Orifice insert

To throttle nominal flows, which are outside of the valve's operating limits.

TECHNICAL DATA ¹⁾

General specifications	
MTTF _d :	According to EN ISO 13849-1:2016 Tables C1 & C2
Ambient temperature:	[°C] -20 to +60
Installation position:	No orientation restrictions
Weight:	[kg] 1.8
Material:	Valve casing: Steel
	Pole tube: Steel
	Coil casing: Steel
	Name plate: Aluminium
Surface coating:	Valve casing: Phosphate plated
	Pole tube: Zn-coating
	Coil casing: ZnNi-coating
Hydraulic specifications	
Operating pressure:	[bar] Port P, A, B: p _{max} = 350
	Port T: p _{max} = 70
Nominal flow:	[l/min] 12
Operating fluid:	Hydraulic oil to DIN 51524 Part 1, 2 and 3
Media operating temperature range:	[°C] -20 to +80
Viscosity range:	[mm ² /s] 15 to 400
Permitted contamination level of operating fluid:	Class 20/18/15 according to ISO 4406
Max. switching frequency:	[1/h] 3,600
Manual override:	up to approx. 50 bar tank pressure available
Sealing material:	FKM
Electrical specifications	
Switching time:	[ms] See table, page 50
Type of voltage:	DC
Rated voltage:	[V] 24
Voltage tolerance:	[%] ±10
Nominal power:	[W] 30
Duty cycle:	[%] 100
Max. surface temperature of the coil:	[°C] 150
Protection class according to DIN EN 60529:	with electrical connection "G" IP65 ²⁾
Sensor data	
Supply voltage:	24 Volt: 20 to 32 VDC
Reverse polarity protection of supply:	Yes
Outputs:	2 with change-over function, PNP, positive switching
Output load:	≤ 400 mA, 100% continuous
Short circuit protection:	Resistant to short circuits
Connector:	Round connector M12x1 (4-pin)
Protection class:	IP65 as per DIN 40050
EC conformity:	93/68/EEC 2014/30/EU
EMC:	DIN EN 6100-6-1-2-3-4
Humidity requirements:	0–95% rel. (as per DIN 40040)
Sensor diagram:	See page 51 "Sensor connections"

¹⁾ see "Conditions and Instructions for Valves" in brochure 53.000

²⁾ if installed correctly

PERFORMANCE

Pressure drop

measured at $v = 30 \text{ mm}^2/\text{s}$ and $T = 45 \text{ }^\circ\text{C}$

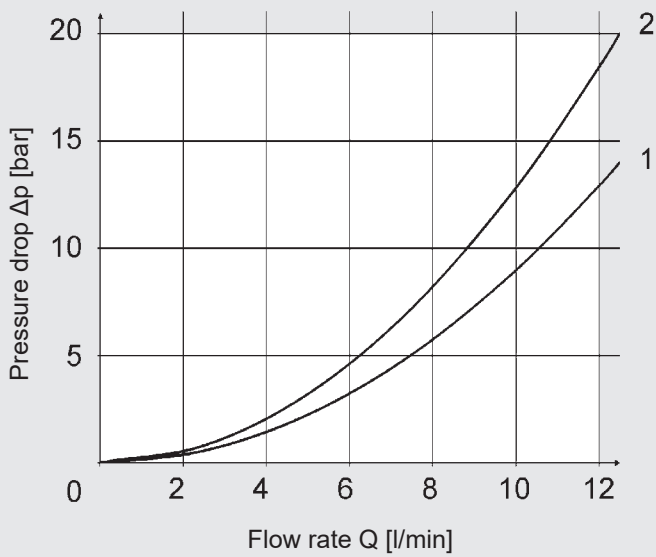

Performance limits

Switch-on current $I_{\text{ON}} \leq 0.7 \times I_{\text{N}}$

Switch-off current $I_{\text{OFF}} \geq 0.07 \times I_{\text{N}}$

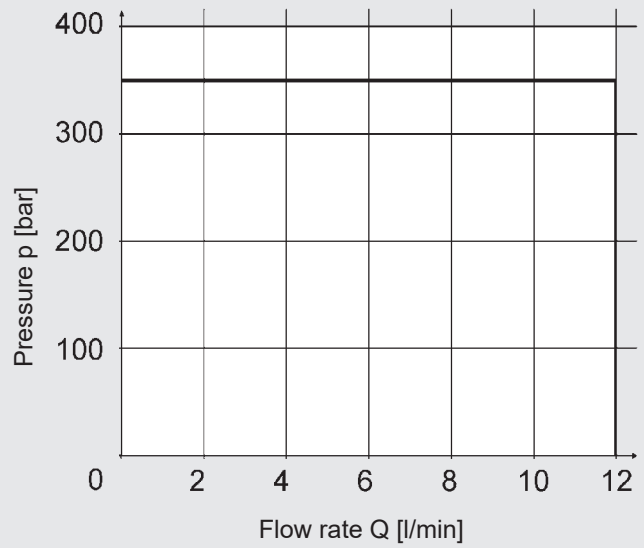

Performance assignment to the associated spools:

Ports	Symbol	Pressure drop						Switching times		
		a			0			On [ms]		Off [ms]
		P-A	P-T	A-T	P-A	P-T	A-T	$0.7 \times I_{\text{N}}$	$1.0 \times I_{\text{N}}$	
2	E2	2						110	50	25
2	BE2				1			110	50	25
2	E4		2					60	40	25
2	BE4					1		60	40	25
3	D			1	2			110	50	25
3	Y	2					1	60	40	25

The performance limits were determined with solenoids at operating temperature and 10% low voltage.

$0.7 \times I_{\text{N}}$ corresponds to switching times at operating temperature

$1.0 \times I_{\text{N}}$ corresponds to switching times at full nominal current

SWITCHING LOGIC

Detection is performed in an almost open and/or closed position.

The almost closed position guarantees reduced leakage.

Symbol

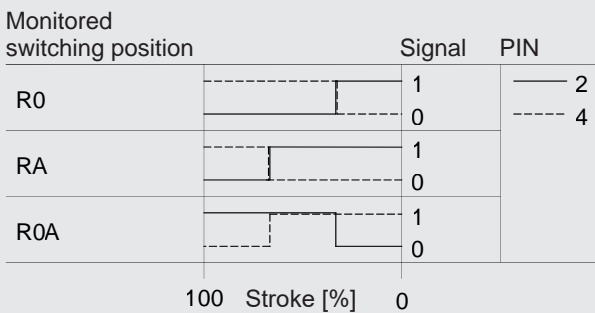
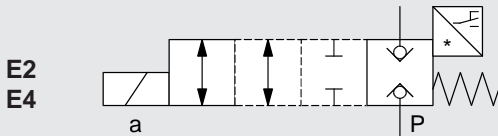
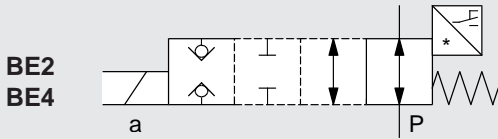

Symbol

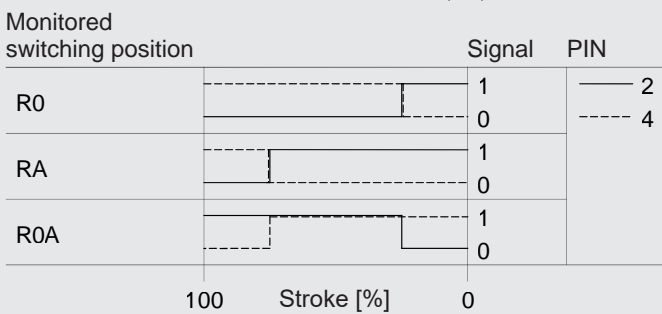
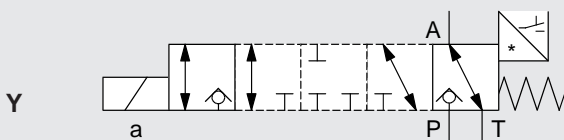

SENSOR DIAGRAMS

Monitoring of one switching position (type R0 and RA)

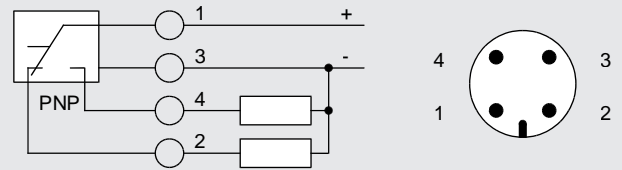

Pin	Value
1	+24 VDC (supply)
2	See "SWITCHING LOGIC"
3	0 V
4	See "SWITCHING LOGIC"

Monitoring of both switching positions (type R0A)

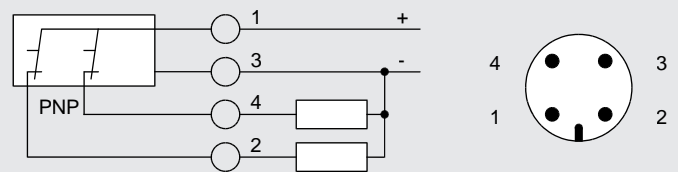

Pin	Value
1	+24 VDC (supply)
2	See "SWITCHING LOGIC"
3	0 V
4	See "SWITCHING LOGIC"

DIMENSIONS

Monitoring of one switching position (type R0 and RA)

2/2, 3/2

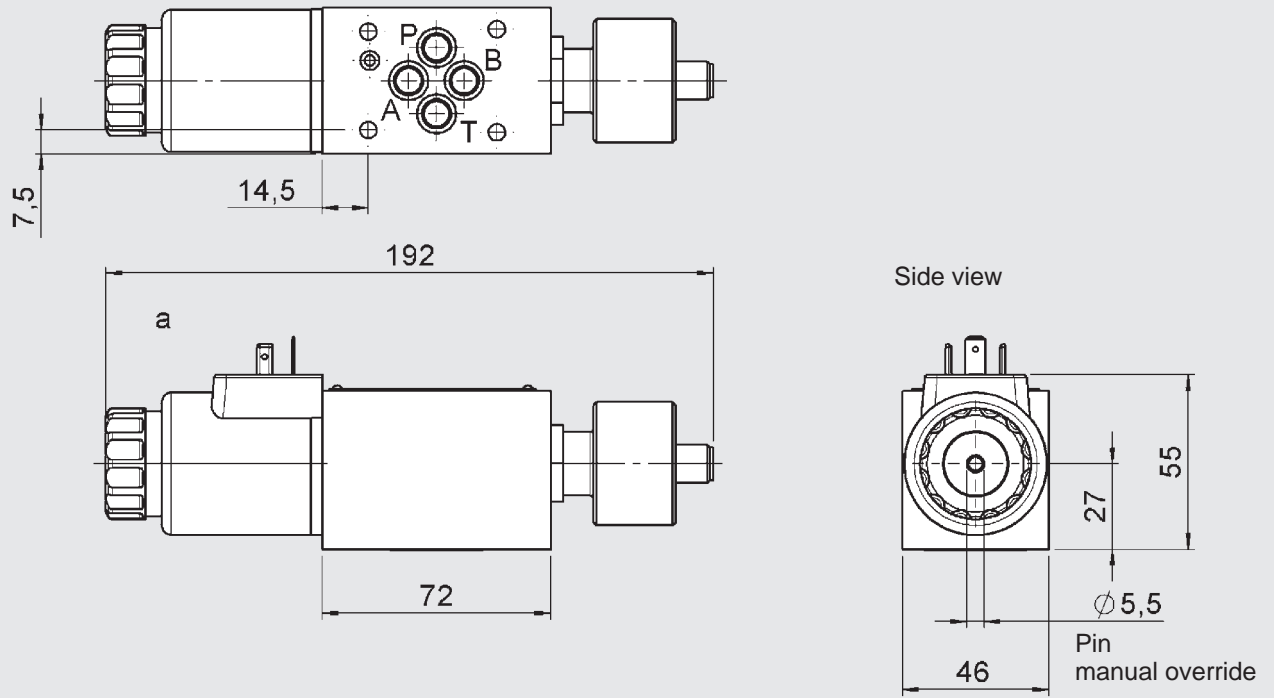

Monitoring of both switching positions (type R0A)

2/2, 3/2

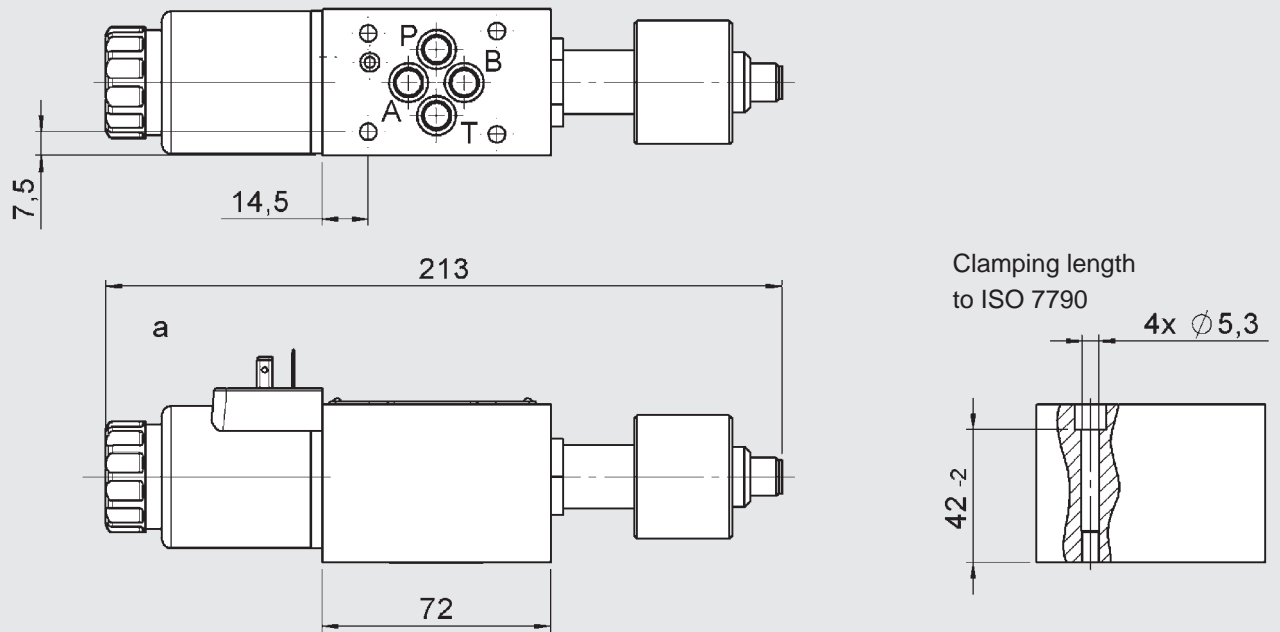

Interface according to ISO 4401-03-02-0-05 (CETOP 3)

Mounting screws:

(not included in delivery)

DIN EN ISO 4762 – M5 x 50 – 10.9

Tightening torque: 7 Nm

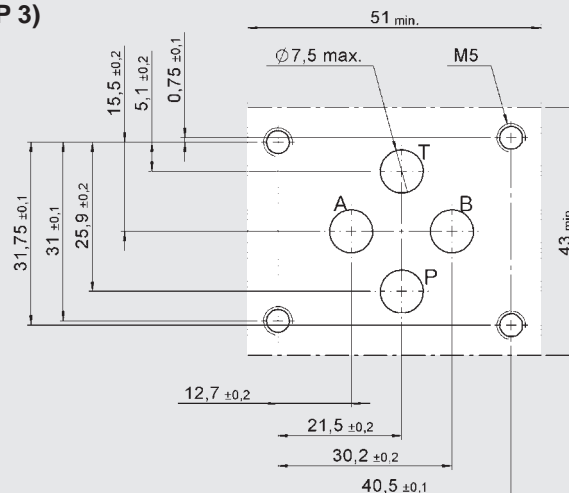

ELECTRICAL CONNECTIONS

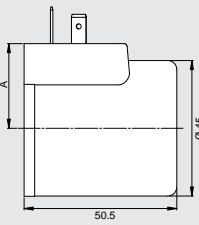
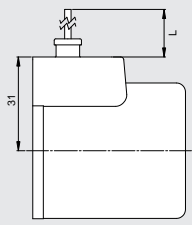
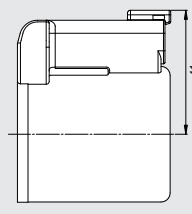
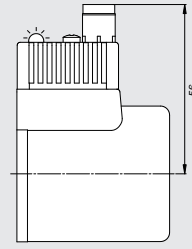
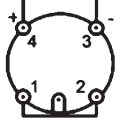
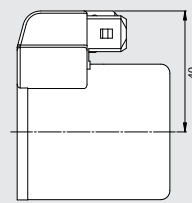
G Device connector DIN EN 175301-803 A		<ul style="list-style-type: none"> ● IP65 ● A = 28 mm for DC (DG)
L 2 strands		<ul style="list-style-type: none"> ● IP65 ● Standard strands length L = 457 mm ● Optional with suppressor diode
N Device connector, Deutsch (DT04-2P)		<ul style="list-style-type: none"> ● IP65 / IP67 ● Optional with suppressor diode
O Device connector M12		<ul style="list-style-type: none"> ● IP65 ● With yellow LED as operation indicator ● Pin assignment 
U Device connector Junior Timer (axial)		<ul style="list-style-type: none"> ● IP65 ● Optional with suppressor diode

Other models on request

MANUAL OVERRIDES

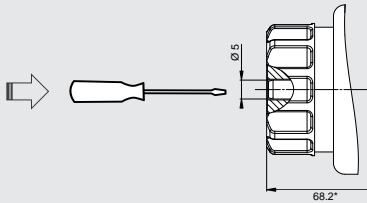
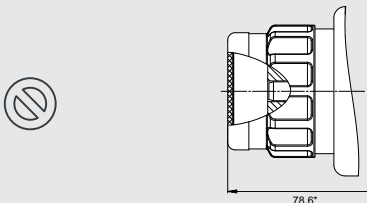
Standard with concealed manual override		Operation with tool
M2 with covered manual override		Manual override covered, operation only possible after disassembly of cap

* Dimensions up to valve housing

In case of emergency, the valve can also be operated manually. There are different forms of manual override available.

The tank pressure should not exceed 50 bar. If the tank pressure is higher, the force required to operate the manual override increases accordingly.

ACCESSORIES

	Designation	Part No.
Seal kits (4-part set)	9.25 x 1.78 80 Sh FKM	3120269
Mounting screws (4 pcs)	DIN EN ISO 4762 - M5 x 50 - 10.9	4312231
Solenoid coils	COIL 24DG -50-2345 -S	4244171
	COIL 24DN -50-2345 -S	4244172
	COIL 24DO -50-2345 -S	4250885
	COIL 24DU -50-2345 -S	4250892
Seal kit for solenoid coil	Nut open, O-ring	4317299
	Nut with cap, O-ring	4317302
Connector	Z4 standard 2-pole without PE	394287
	Z4L incl. LED	394285
Orifice insert	Orifice for WSER 6 H01	4371106
Check valve	RV for WSER 6 H01	4371006

Note

The information in this brochure relates to the operating conditions and applications described. For applications or operating conditions not described, please contact the relevant technical department.

Technical modifications are reserved.

4/2 and 4/3-directional spool valves lever operated 4WMH 6 to 10

DESCRIPTION

HYDAC 4/2- and 4/3- directional spool valves of the 4WMH series are directional valves for oil hydraulic systems, which are used for direction control of oil flow.

The valve is operated by a hand lever.

The mechanism pushes the control piston of the valve to the respective position to obtain the desired flow paths.

FEATURES

- Interface to ISO 4401
- Versions with two or three switching positions, with return spring or mechanical detent
- Valve body with high stability and low flow losses
- NG6: Position of the hand lever can be turned by 180°



CONTENT

Description

Features

Model code

Accessories

Spool types / Symbols

Technical Data

Function

Section view

Performance

Dimensions

MODEL CODE

4WMH 6 E - F 01 / V

Type

Manually operated directional valves with hand lever and 4 main ports

Nominal size (NG)

6, 10

Spool types

see chapter „Spool types / Symbols“

Design

Not specified = with return spring
F = without spring, with detent

Series

01 = determined by the manufacturer

Sealing material

V = FKM (standard)
N = NBR

ACCESSORIES

	Designation	Part no.
Seal kits	NG6: 9,25 x 1,78 80 Sh NBR	3492432
	9,25 x 1,78 80 Sh FKM	3120269
	NG10: 12,42 x 1,78-NBR -80Sh	4348706
	12,4 2x 1,78-FKM -80Sh	4348705
Mounting screws (4 pcs)	NG6: DIN EN ISO 4762 - M5 x 50 - 10.9	4312231
	NG10: DIN EN ISO 4762 - M6 x 40 - 10.9	3524314

SPOOL TYPES / SYMBOLS

4/2- DIRECTIONAL SPOOL VALVES

Type	Symbol with intermediate position
D	
D-F	
C	
C-F	
EA	
EA-F	
HA	
HA-F	
JA	
JA-F	
GA	
GA-F	

4/3- DIRECTIONAL SPOOL VALVES

Type	Symbol with intermediate position
E	
E-F	
H	
H-F	
J	
J-F	
G	
G-F	

FUNCTION

The manually operated directional spool valve of the 4WMH series are used for directional control of flow.

The valves consists of a valve casing (1) and a valve piston (2).

Depending on the version, the valve is equipped with a return spring or a detent (option F).

The valve piston is held in its initial position by the return spring.

The valve is operated by a hand lever (3).

The mechanism pushes the control piston of the valve to the respective position to obtain the desired flow paths.

The hand lever is locked with option F, so the is held in its position.

If the lever is returned after actuation, the piston is moved back to its initial position by the return spring.

SECTION VIEW

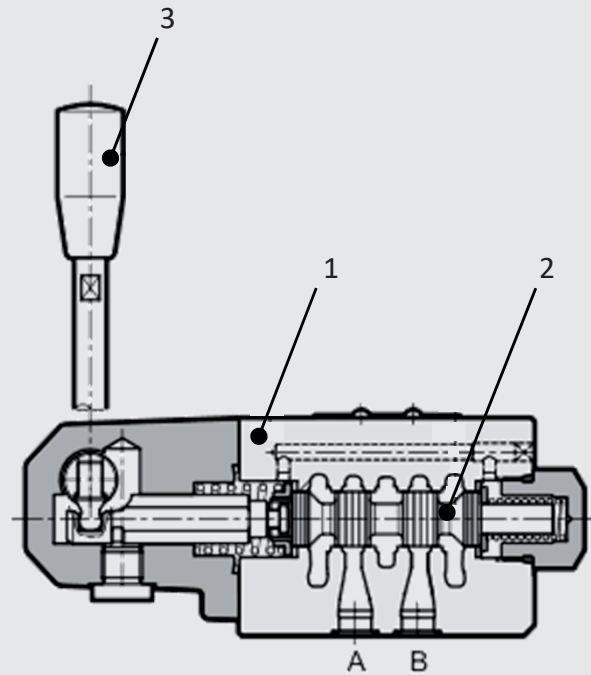

TECHNICAL DATA *

General specifications		
		Nominal size
		6 10
MTTFd		To EN ISO 13849-1:2015 chart C1 & C2
Ambient temperature	[°C]	-20 to +60
Installation position		without detent: no orientation restrictions with detent: horizontal (direct axis)
Weight	[kg]	1,3 4,2
Hydraulic specifications		
		Nominal size
		6 10
Operating pressure port A, B, P	[bar]	350 320
Operating pressure port T		210 160
Flow range	[l/min]	see chart „Performance“
Operating fluid		Hydraulic oil to DIN 51524 part 1, 2 and 3
Viscosity range	[mm ² /s]	10 to 400 (25 is recommended)
Permitted contamination level of operating fluid		class 20/18/15 to ISO 4406
Sealing material		FKM (standard), NBR

* see "Conditions and instructions for Valves" in brochure 53.000

PERFORMANCE

The performance curves represent the valve's areas of application for different spool types depending on flow rate and operating pressure. The values are taken according to ISO 6403 standard, with mineral oil viscosity of 36 mm²/s, at an operating temperature of 50 °C and filters according to ISO4406:1999 class 18/16/13.

HINT

The values in the diagrams are valid for normal operation. The performance limits can be reduced considerably, e.g. if a 4-directional valve with blocked port A or B is operated.

NG6

Pressure drop

measured at $v = 36 \text{ mm}^2/\text{s}$, $T = 50 \text{ °C}$

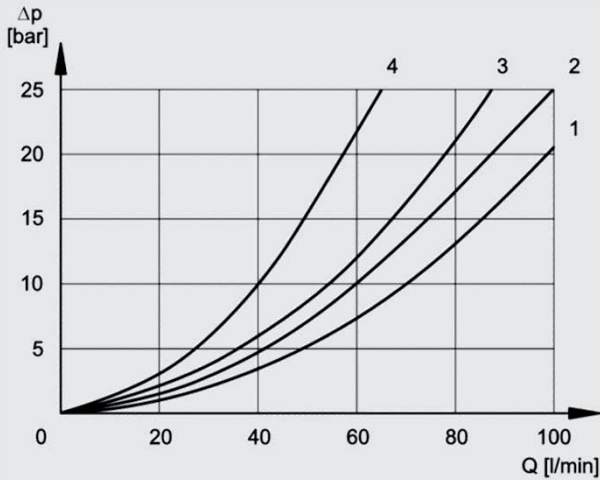

Performance limits

measured at $v = 36 \text{ mm}^2/\text{s}$, $T = 50 \text{ °C}$

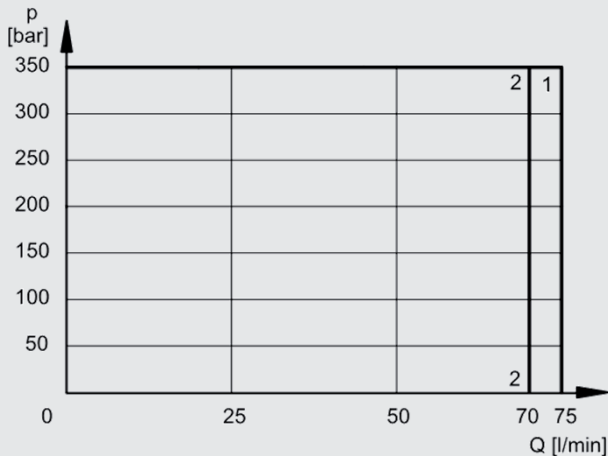

Performance assignment to the associated spools:

spool	Pressure drop					Performance limits (P-A/P-B)
	P-A	P-B	A-T	B-T	P-T	
E, EA	2	2	3	3		1
H, HA	1	1	3	3	(2)	1
J, JA	3	3	1(3)	1(3)		1
G, GA	4	4	4	4	(3)	2
D	3	3	3	3		1
C	2	2	2	2		1

(*): valve in basic position

NG10

Pressure drop

measured at $v = 36 \text{ mm}^2/\text{s}$, $T = 50 \text{ °C}$

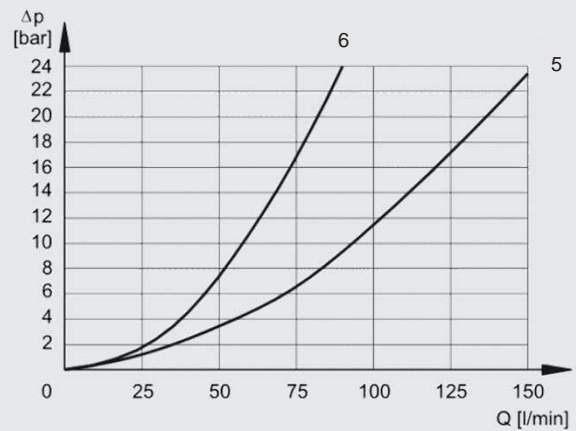
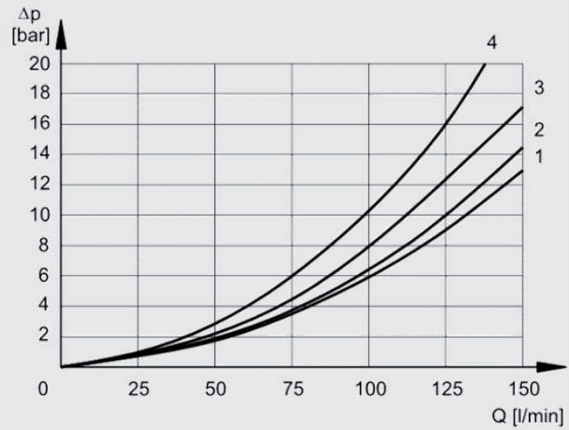

Performance limits

measured at $v = 36 \text{ mm}^2/\text{s}$, $T = 50 \text{ °C}$

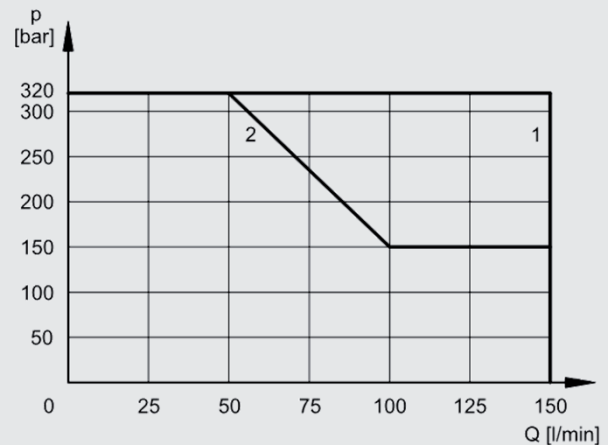

Performance assignment to the associated spools:

spool	Pressure drop					Performance limits (P-A/P-B)
	P-A	P-B	A-T	B-T	P-T	
E, EA	2	2	1	1		1
H, HA	3	3	1	1	(5)	1
J, JA	3	3	2(6)	2(6)		1
G, GA	1	1	2	2	(5)	2
D	3	3	2	2		1

(*): valve in basic position

DIMENSIONS NG6

Interface to ISO 4401-03-02-0-05

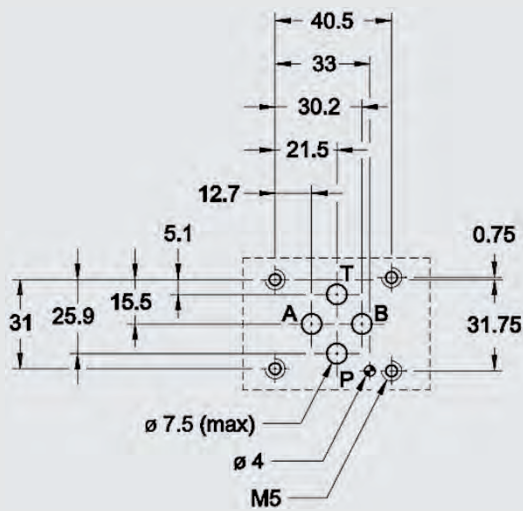

Mounting screws:

(not included in delivery)
 DIN EN ISO 4762- M5x30- 8.8
 Torque: 5 Nm

4/3-way

4/2-way

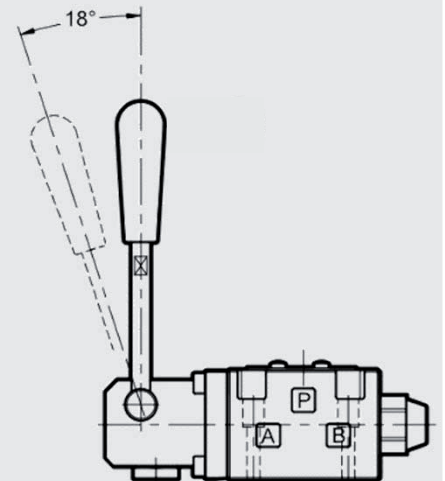
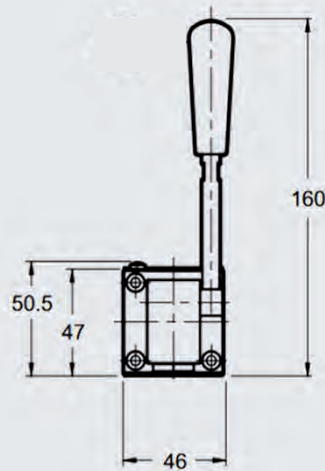
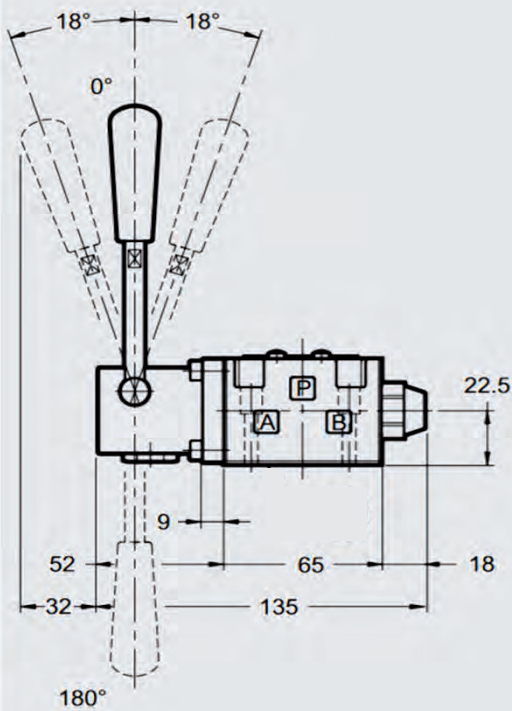

HINT

The valve is supplied with the hand lever pointing orthogonally to the interface. The lever can be turned 180° for different applications.

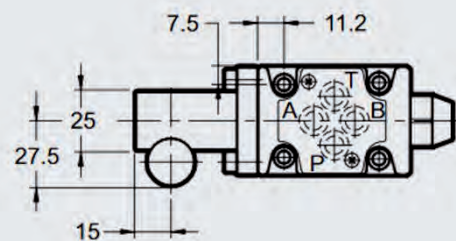

DIMENSIONS NG10

CETOP 4.2-4-05-320

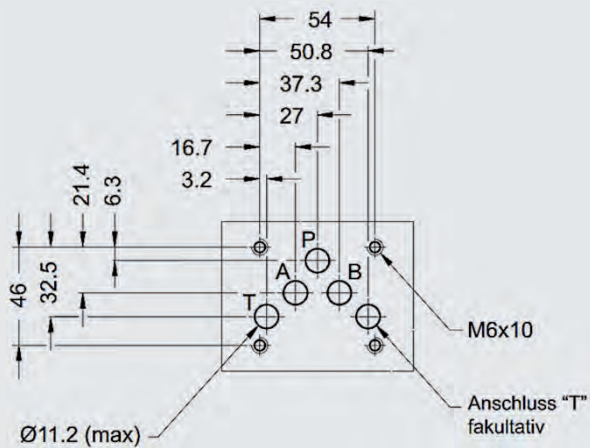

Mounting screws:
(not included in delivery)
DIN EN ISO 4762- M6x40- 8.8
Torque: 8 Nm

4/3-way

4/2-way

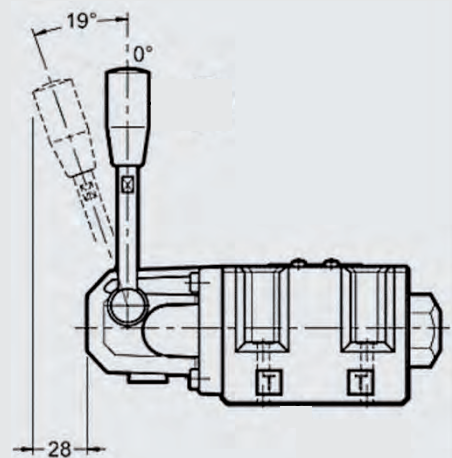
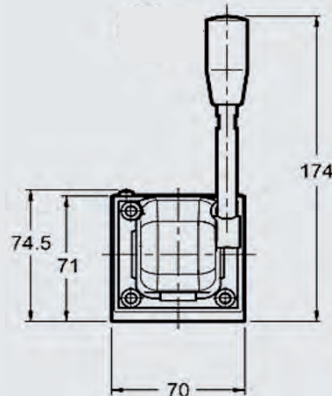
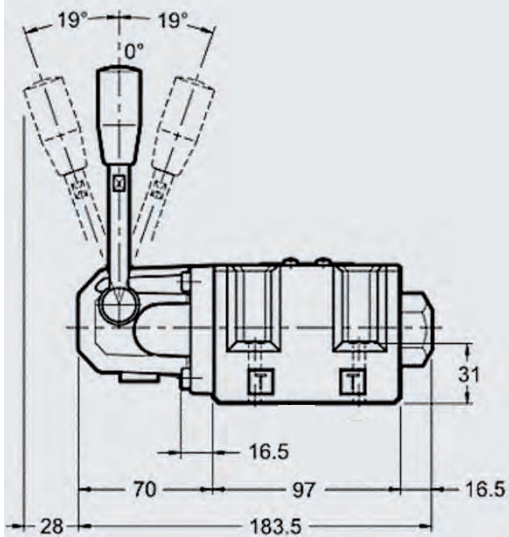

HINT

The orientation of the hand lever can not be changed.

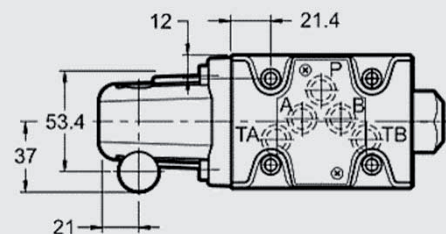

Note

The information in this brochure relates to the operating conditions and applications described. For applications not described, please contact the relevant technical department. All technical details are subject to change without notice.

HYDAC Fluidtechnik GmbH
Justus-von-Liebig-Str.
D-66280 Sulzbach/Saar
Tel: 0 68 97 /509-01
Fax: 0 68 97 /509-598
E-Mail: valves@hydac.com

4/2- and 4/3-directional spool valve hydraulically operated 4WH 10

DESCRIPTION

The 4WH valves in nominal size 10 are directional spool valves with hydraulic operation. They are used to control the start, stop and direction of the volume flow.

A wide variety of spool types and options for opening control are available in this valve series.

FEATURES

- Hydraulically operated directional spool valve
- Electro-hydraulic operation via pilot valve NG 6 or hydraulic operation via interconnecting plate
- Volume flow rates up to 150 l/min
- The pilot supply and/or drain can be internal or external, which can be achieved by changing the plugs
- Interface according to ISO 4401-05 and CETOP P05



Nominal size 10
up to 150 l/min
up to 320 bar

CONTENTS

Description

Features

Model code

Spool types / symbols

Function

Section view

Technical Data

Performance

Dimensions

Accessories

MODEL CODE

4WH E 10 D S01 /V /H

Type

4/2- or 4/3 - directional spool valve, hydraulically operated

Control type

- E = external pilot supply and drain
- EI = external pilot supply, internal pilot drain
- I = internal pilot supply and drain (not for symbol G and H)
- IE = internal pilot supply, external pilot drain
(preload tank line: pressure between pilot and drain must be more than minimum pilot pressure)

Nominal size

10

Spool symbol¹⁾

see page 64

Series

- S01 = CETOP 4.2-4 P05-320 (Standard)
- S02 = ISO 4401-05-05-0-05

Sealing material

- N = NBR
- V = FKM (standard)

Options

- Not specified = without interconnecting plate (standard)
- H = with stroke limitation of main spool

¹⁾ Other models on request

SPOOL TYPES / SYMBOLS

4/2-DIRECTIONAL SPOOL VALVES

Type	Basic symbol	With intermediate position
D		

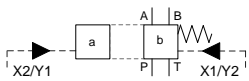

4/3-DIRECTIONAL SPOOL VALVES

Type	Basic symbol	With intermediate position
E		
G		
H		
J		
Q		

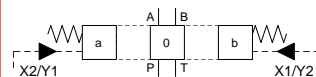

FUNCTION

The valves of the 4WH 10 type are directional spool valves, with hydraulic operation, which can control the start, stop and direction of the volume flow. They consist of the valve housing (1), the main control spool (2) and the return springs (3).

The fluid power supply of the valve is provided centrally via standard porting pattern.

Without pilot oil, the main control spool is centered in its middle position by the springs. The actuation of the main control spool (2) is caused by pressurisation. The required pilot oil is provided by port X and Y or is controlled by an additional pilot valve that is adopted to the main valve. The pilot pressure depends on rate of volume flow. The minimal pilot pressure of 5 bar is sufficient only for low rates of volume flow. Pilot pressure has to be increased up to 12 bar by increasing rates of volume flow.

Pressure loading on one of the two front sides of the main control spool (2) with pilot pressure causes the desired switching position, whereby the required ports will be linked.

The spring, which is across from the pressurised control piston surface, causes the resetting of the piston into zero or initial position by relieving of pressure.

Two valve versions in nominal size 10 with different and non-compatible standard porting patterns are available for the hydraulic controlled valves of 4WH. The pilot pressure supplies X and Y are in different positions on the porting pattern. In the process, port X takes the pilot oil supply and port Y relieves the pressure of the pilot stage on the tank level of the pilot circuit. Port Y is used for pilot oil drain purposes and usually flows unpressurized (leakage port) into the tank.

Version **S01** according to ISO 4401-05-05-0-05

Version **S02** according to CETOP 4.2-4 P05-350

SECTION VIEW

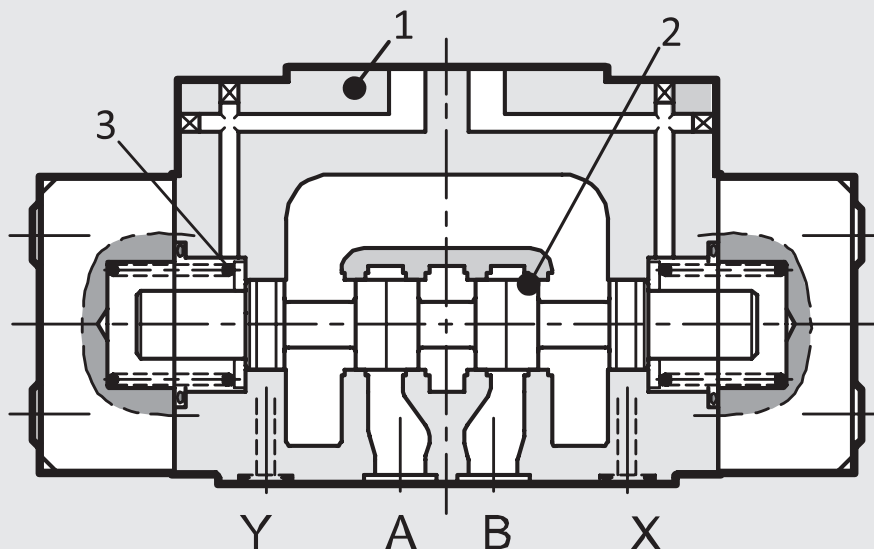

Control types – Pilot oil supply and pilot oil drain

If the valve is used as a hydraulic actuated valve, the pilot oil supply and pilot oil drain will occur externally via port X and Y.

If the valve is used as main stage in a pilot-operated valve, there are four possible control types for each basic code. This can be seen in the model code.

The valve will be delivered correspondingly configured. Modification is possible afterwards. The glued threaded plugs will make disassembly more difficult.

- **Version "E"** – Pilot oil supply is external from a separate fluid power supply via port X. The pilot oil drain is also external via port Y.
- **Version "EI"** – Pilot oil supply is external from a separate fluid power supply via port X. The pilot oil drain is internal via port T.
- **Version "IE"** – Pilot oil supply is internal via port P. The pilot oil drain is external via port Y. Hint: Preload tank line - Pressure between pilot and drain must be more than minimum pilot pressure
- **Version "I"** – Pilot oil supply is internal via port P. The pilot oil drain is internal via port T. Hint: Not for symbol G and H.

TECHNICAL DATA

General specifications	
MTTF _d :	According to EN ISO 13849-1:2015 C1 & C2
Ambient temperature range: [°C]	-20 to +50
Installation position:	No orientation restrictions
Weight: [kg]	5.0
Material:	Valve casing: Cast iron
	Type plate: Aluminium
Surface coating:	Valve casing: Phosphate plated
Hydraulic specifications	
Operating pressure: [bar]	Port A, B, P: p _{max} = 320 Port T: p _{max} = 210
Pilot pressure min: [bar]	5 to 12 ²
Pilot pressure max: [bar]	210
Nominal flow: [l/min]	150
Operating fluid:	Hydraulic oil to DIN 51524 Part 1, 2 and 3
Media operating temperature range: [°C]	-20 to +80
Viscosity range: [mm ² /s]	10 to 400
Permitted contamination level of operating fluid:	Class 20/18/15 according to ISO 4406
Sealing material:	FKM (Standard), NBR

¹ see "Conditions and Instructions for Valves" in brochure 53.000

² Pilot pressure depends on rate of delivery flow. The minimal pilot pressure is sufficient only for low rates of delivery flow. If the rate of delivery flow increases, it is necessary to increase the pilot pressure up to the specified maximum value.

PERFORMANCE

Pressure drop

measured at $v = 36 \text{ mm}^2/\text{s}$, $T = 50 \text{ °C}$

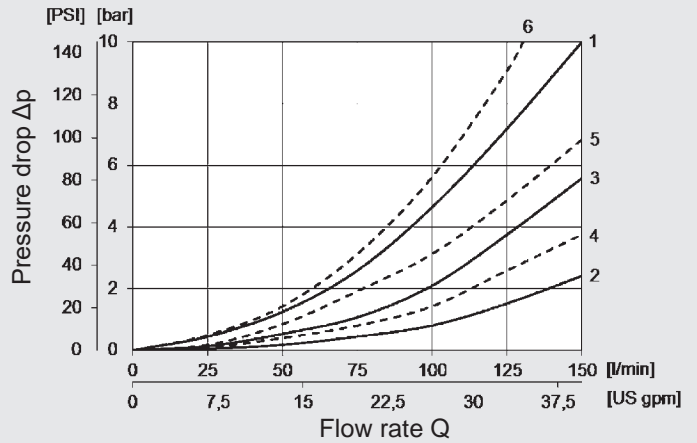

Performance limits

measured at $v = 36 \text{ mm}^2/\text{s}$, $T = 50 \text{ °C}$

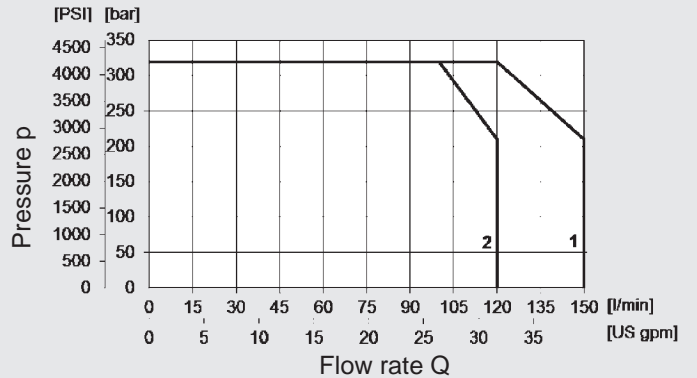

Performance assignment to the associated spools:

Spool	Switching position	Pressure drop					Performance limits
		P→A	P→B	A→T	B→T	P→T	
D	not operated	1			3		1
	operated		1	4			
E	not operated						1
	operated	1	1	2	3		
G	not operated					6	2
	operated	6	6	3	5		
H	not operated					6*	1
	operated	5	5	2	4		
J	not operated			1●	1○		1
	operated	1	1	2	4		
Q	not operated						1
	operated	1	1	2	2		

* A-B blocked ● B blocked ○ A blocked

DIMENSIONS

Interface according to CETOP 4.2-4 P05-320

Interface according to ISO 4401-05-05-0-05 (CETOP R5)

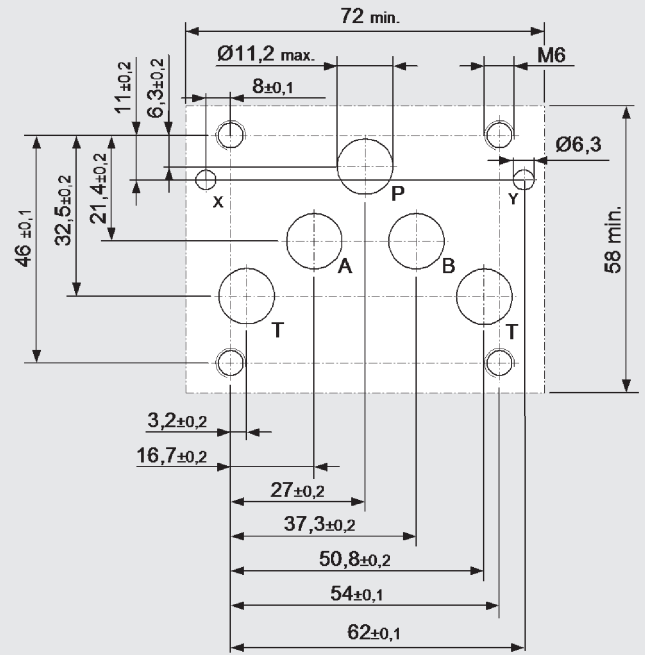
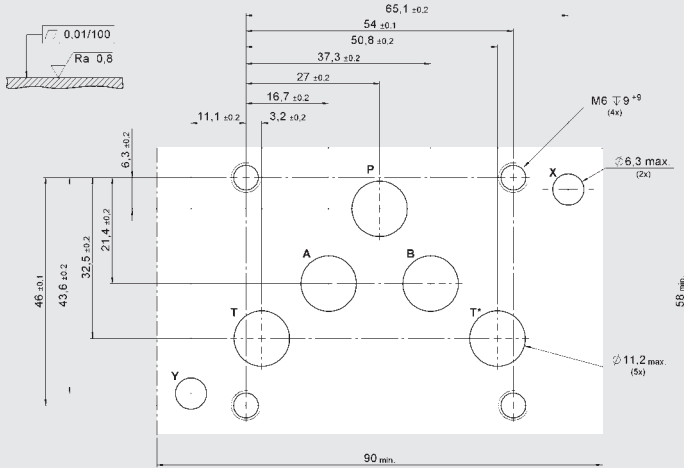

Mounting screws:

(not included in delivery)

4 screws M6x35 ISO 4762

Tightening torque: 12 Nm (screws A 10.9)

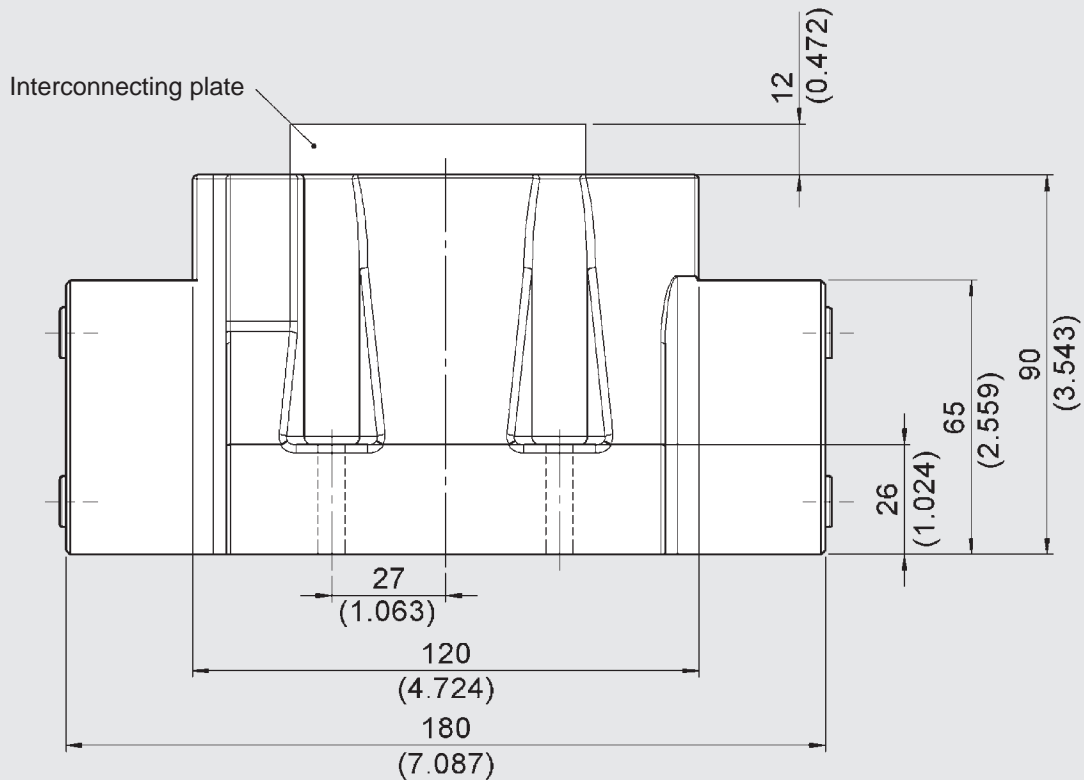
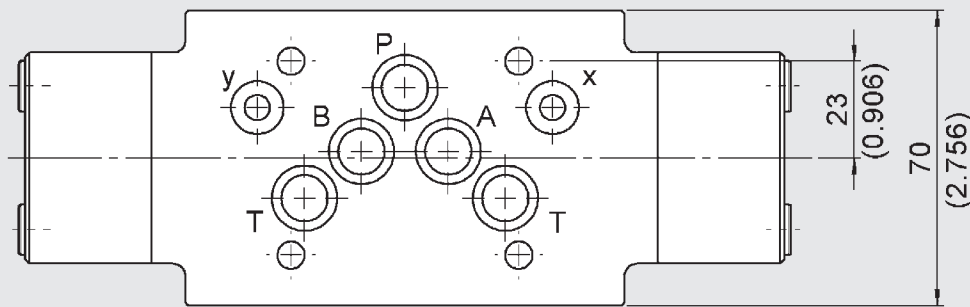

Plug

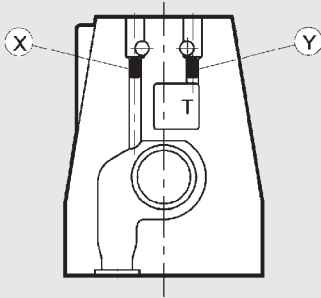

X: M5x6
for external pilot oil supply
Y: M5x6
for external pilot oil drain

		Installation		Control type
		X	Y	
E	Pilot oil drain and supply external	•	•	hydraulically or pilot valve
EI	Pilot oil supply external, pilot oil drain internal	•	–	pilot valve
I	Pilot oil drain and supply internal	–	–	pilot valve
IE	Pilot oil supply internal, pilot oil drain external	–	•	pilot valve

Plates

Check plate

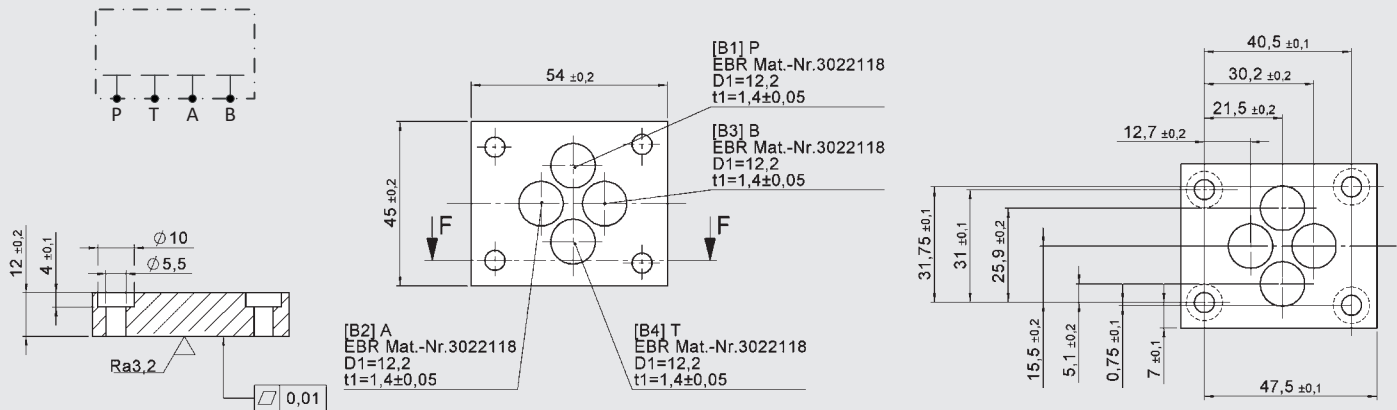

Interconnecting plates

PATB

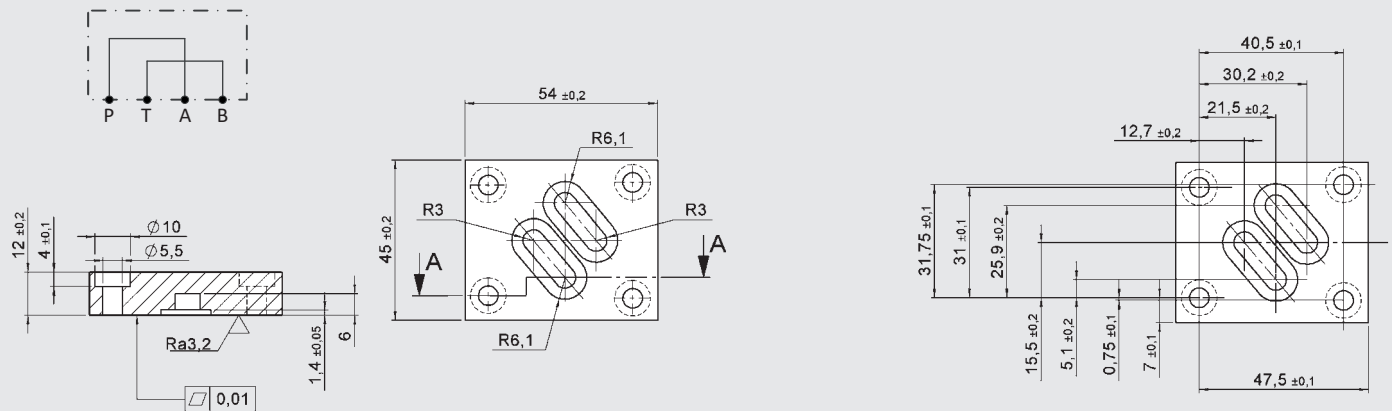

PBTA

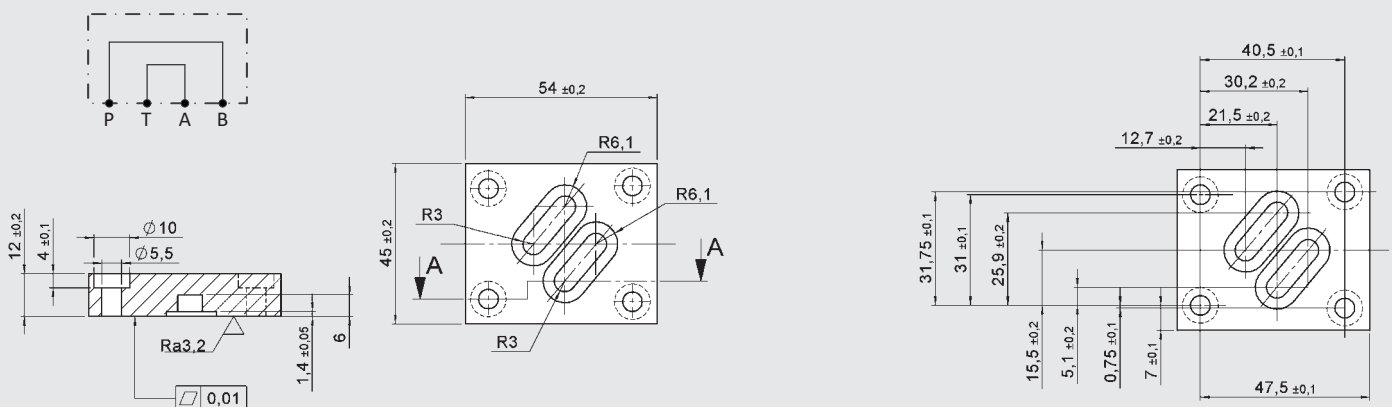

ACCESSORIES

	Designation	Part no.
Seal kits (7-part set)	12.42 x 1.78 -NBR -90 Sh (5 pieces)	3524475
	9.25 x 1.78 -NBR -90 Sh (2 pieces)	
	12.42 x 1.78 -FKM -90 Sh (5 pieces)	3524523
	9.25 x 1.78 -FKM -90 Sh (2 pieces)	
Mounting screws (4 pcs)	DIN EN ISO 4762-M6x35-10.9	3524691
Plug	M5x6 -45H	4452918
Plates	Check plate -NBR	3611576
	Check plate -FKM	3611580
	Interconnecting plate PATB -NBR	3581660
	Interconnecting plate PATB -FKM	3581661
	Interconnecting plate PBTA -NBR	3581662
	Interconnecting plate PBTA -FKM	3581663

NOTE

The information in this brochure relates to the operating conditions and fields of application described. For applications not described, please contact the relevant technical department. All technical details are subject to change without notice.

HYDAC Fluidtechnik GmbH
 Justus-von-Liebig-Str.
D-66280 Sulzbach/Saar
 Tel.: 0 68 97 /509-01
 Fax: 0 68 97 /509-598
 E-mail: valves@hydac.com

4/2- and 4/3-directional spool valve Hydraulically operated 4WH 16

DESCRIPTION

The valves in nominal size 16 of the 4WH series are directional spool valves with hydraulic operation. They are used to control the start, stop and direction of the volume flow.

A wide variety of piston types and options for opening control are available in the context of the valve series.

FEATURES

- Hydraulically operated directional spool valve
- Electro-hydraulic operation via pilot valve NG 6 or hydraulic operation via interconnecting plate
- Flow rates up to 300 l/min
- The pilot supply and/or drain can be internal or external and can be achieved by changing the plug
- Interface according to ISO 4401-07



Nominal size 16
up to 300 l/min
up to 350 bar

CONTENTS

Description

Features

Model code

Spool types / symbols

Function

Section view

Technical data

Performance

Dimensions

Accessories

MODEL CODE

4WH E 16 G S01 /V /G

Type

4/2- or 4/3-directional spool valve, hydraulically operated

Control type

- E = external pilot drain and supply
- EI = external pilot supply, internal pilot drain
- I = internal pilot supply and drain (symbol G and H only with option G)
- IE = internal pilot supply, external pilot drain (symbol G and H only with option G)

Nominal size

16

Spool symbol ¹⁾

See page 72

Series

S01 = ISO 4401-07-07-0-05 (CETOP 4.2-4-07-320)

Sealing material

- N = NBR
- V = FKM (standard)

Options

- Not specified = without interconnecting plate (standard)
- G = with check valve

¹⁾ Other models on request

SPOOL TYPES / SYMBOLS

4/2-DIRECTIONAL SPOOL VALVES

Type	Basic symbol	With intermediate position
C		
D		
Y		

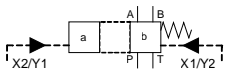

4/3-DIRECTIONAL SPOOL VALVES

Type	Basic symbol	With intermediate position
E		
G		
H		
J		
L		
Q		

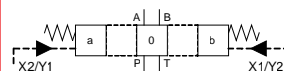

FUNCTION

The valves of the 4WH 16 series are directional spool valves with hydraulic operation which can control the start, stop and direction of the volume flow. They consist of the valve casing (1), the main control spool (2) and the return springs (3).

The fluid power supply of the valve is provided centrally via the standard porting pattern.

Without pilot oil, the main control spool is centred in its middle position by the springs. The actuation of the main control spool (2) is caused by pressurisation. The required pilot oil is provided by port X and Y or is controlled by an additional pilot valve that is adopted to the main valve. The pilot pressure depends on rate of flow. The minimal pilot pressure of 5 bar is sufficient only for low rates of flow. Pilot pressure has to be increased up to 12 bar by increasing rates of volume flow. Pressure loading on one of the two front sides of the main control spool (2) with pilot pressure causes desired switching position, whereby the required ports will be linked. The spring, which is across from the pressurised control piston surface, causes the resetting of the piston into zero or initial position by relieving of pressure.

SECTION VIEW

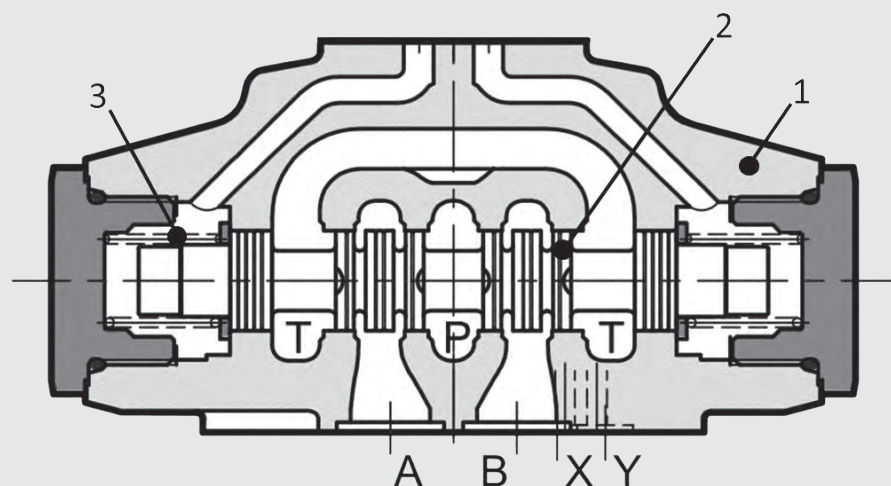

Control types – Pilot supply and pilot drain

If the valve is used as a hydraulically actuated valve, the pilot supply and pilot drain will occur external via port X and Y.

If the valve is used as main stage in a pilot-operated valve, there are four possible control types for each basic valve. This can be seen in the model code.

The valve will be delivered correspondingly configured. Modification is possible afterwards. The glued threaded plugs will make disassembly more difficult.

- **Version "E"** – Pilot supply is external from a separate fluid power supply via port X. The pilot drain is also external via port Y.
- **Version "EI"** – Pilot supply is external from a separate fluid power supply via port X. The pilot drain is internal via port T.
- **Version "IE"** – Pilot supply is internal via port P. The pilot drain is external via port Y.
Hint: Symbols G and H only with option G.
- **Version "I"** – Pilot supply is internal via port P. The pilot drain is external via port T.
Hint: Symbols G and H only with option G.

TECHNICAL DATA¹

General specifications	
MTTF _d :	According to EN ISO 13849-1:2015 chart C1 & C2
Ambient temperature range: [°C]	-20 to +50
Installation position:	No orientation restrictions
Weight: [kg]	6.6
Material:	Valve casing: Cast iron
	Name plate: Aluminium
Surface coating:	Valve casing: Phosphate plated

Hydraulic specifications	
Operating pressure: [bar]	350
Pilot pressure min: [bar]	5 to 12 ²
Pilot pressure max: [bar]	210
Nominal flow: [l/min]	300
Operating fluid:	Hydraulic oil to DIN 51524 Part 1, 2 and 3
Media operating temperature range: [°C]	-20 to +80
Viscosity range: [mm ² /s]	10 to 400
Permitted contamination level of operating fluid:	Class 20/18/15 according to ISO 4406
Sealing material:	FKM (standard), NBR

¹ see "Conditions and Instructions for Valves" in brochure 53.000
² Pilot pressure depends on rate of delivery flow. The minimal pilot pressure is sufficient only for low rates of delivery flow. If the rate of delivery flow increases, it is necessary to increase the pilot pressure up to the specified maximum value.

PERFORMANCE

Pressure drop
 measured at $v = 36 \text{ mm}^2/\text{s}$, $T = 50 \text{ °C}$

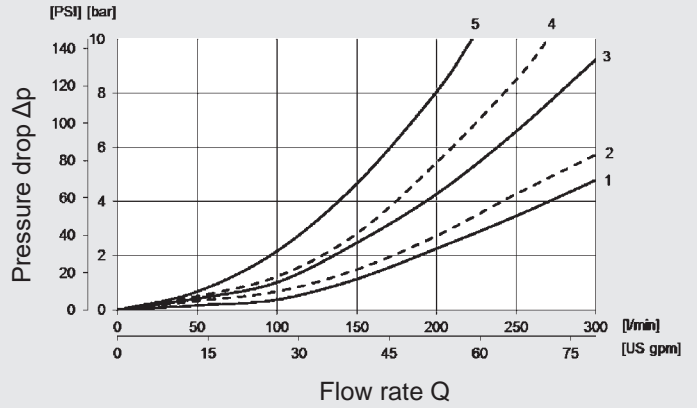

Performance limits
 measured at $v = 36 \text{ mm}^2/\text{s}$, $T = 50 \text{ °C}$

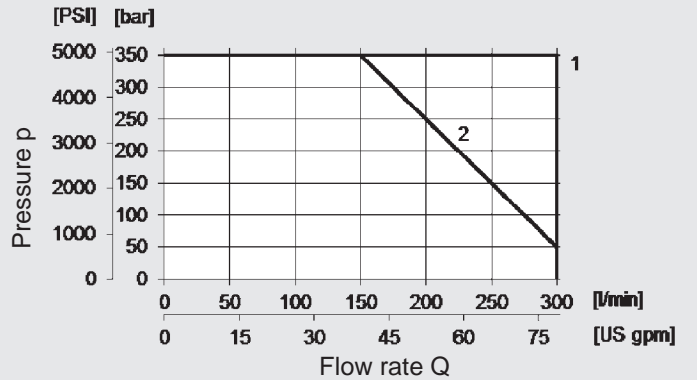

Performance assignment to the associated spools:

Spool	Switching position	Pressure drop					Performance limits
		P-A	P-B	A-T	B-T	P-T	
C	Not operated	1			4		1
	Operated		1	4			
D	Not operated	1			4		1
	Operated		1	3			
E	Not operated						1
	Operated	1	1	3	4		
J	Not operated			4●	4○		1
	Operated	1	1	4	4		
H	Not operated					2**	1
	Operated	1	1	4	4		
G	Not operated					4	2
	Operated	2	2	4	5		
L	Not operated			4			1
	Operated	1	1	3	4		
Q	Not operated						1
	Operated	1	1	3	4		
Y	Not operated		1	3			1
	Operated	1			4		

** A-B blocked ● B blocked ○ A blocked

DIMENSIONS

Interface according to ISO 4401-07-07-0-05 (CETOP 4.2-4-07-320)

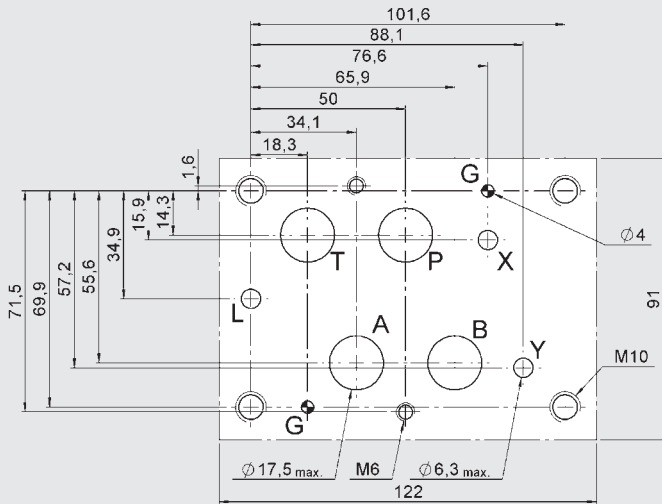

Mounting screws:

(not included in delivery)

4 screws M10x60 and 2 screws M6x50 ISO 4762

Tightening torque:

M10x60: 57 Nm (screws A 10.9)

M6x50: 14 Nm (screws A 10.9)

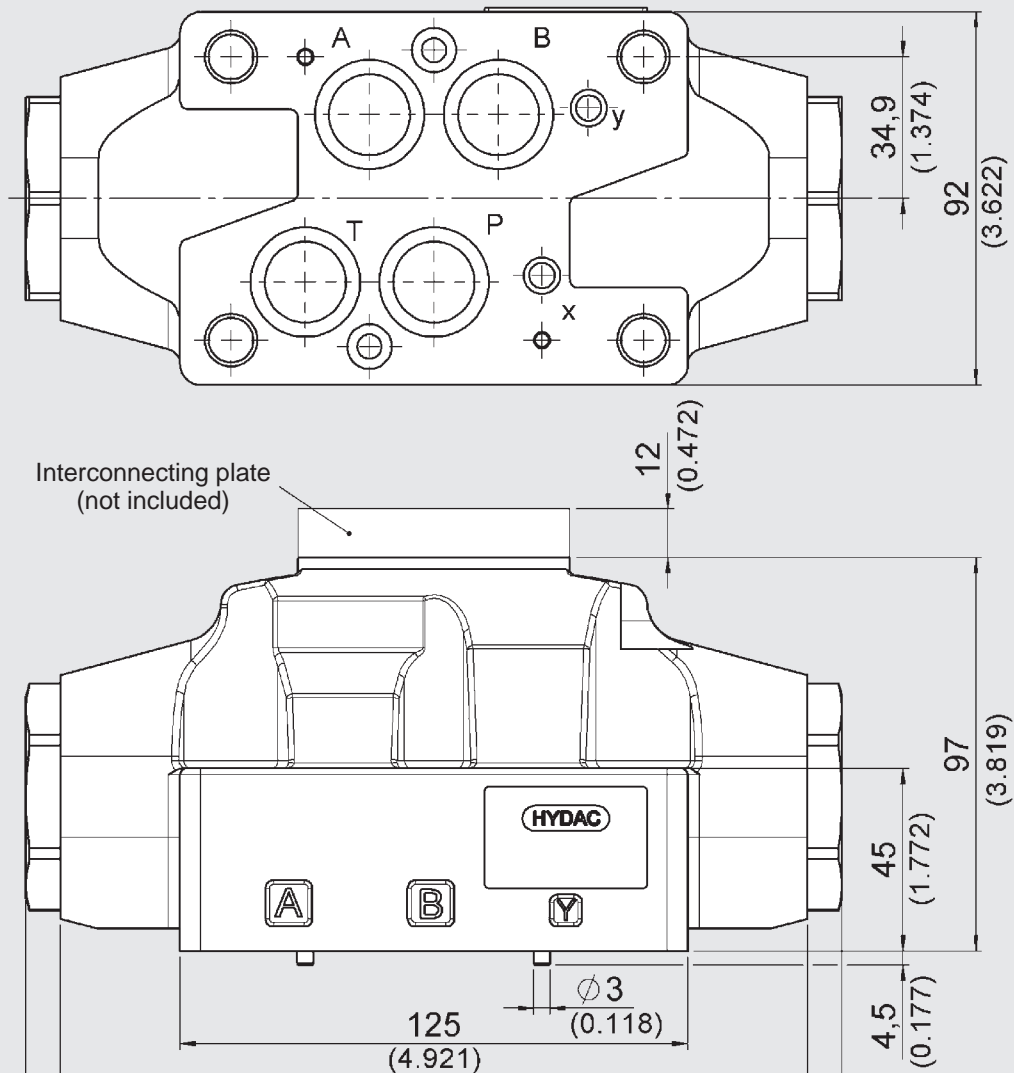

Plug

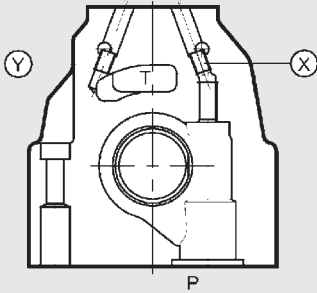

X:
M6x8 for external pilot supply

Y:
M6x8 for external pilot drain

Control type		Installation		Control
		X	Y	
E	external pilot drain and supply	•	•	hydraulically or pilot operated
EI	external pilot supply, internal pilot drain	•	–	pilot operated
I	internal pilot drain and supply	–	–	pilot operated
IE	internal pilot supply, external pilot drain	–	•	pilot operated

Plates

Check plate

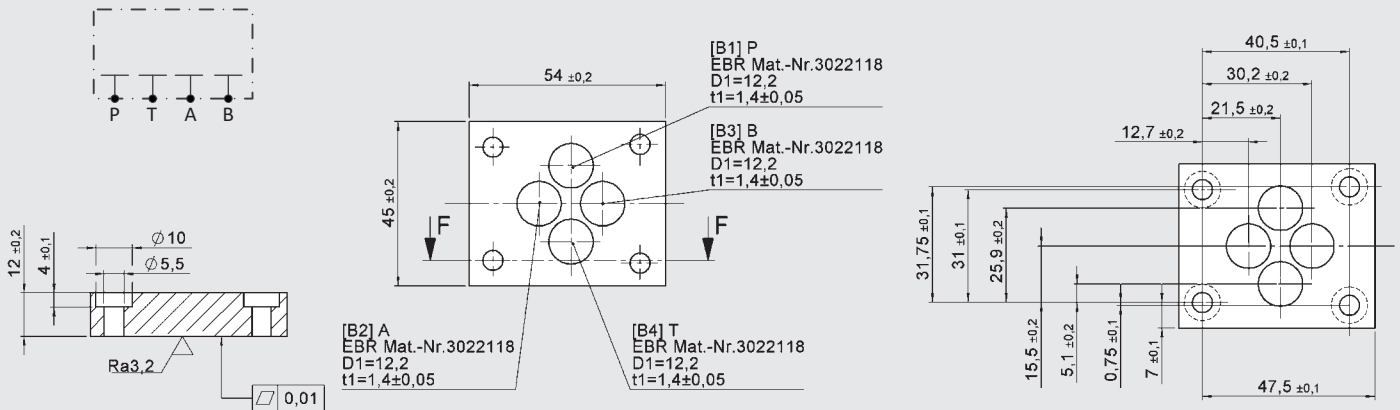

Interconnecting plates

PATB

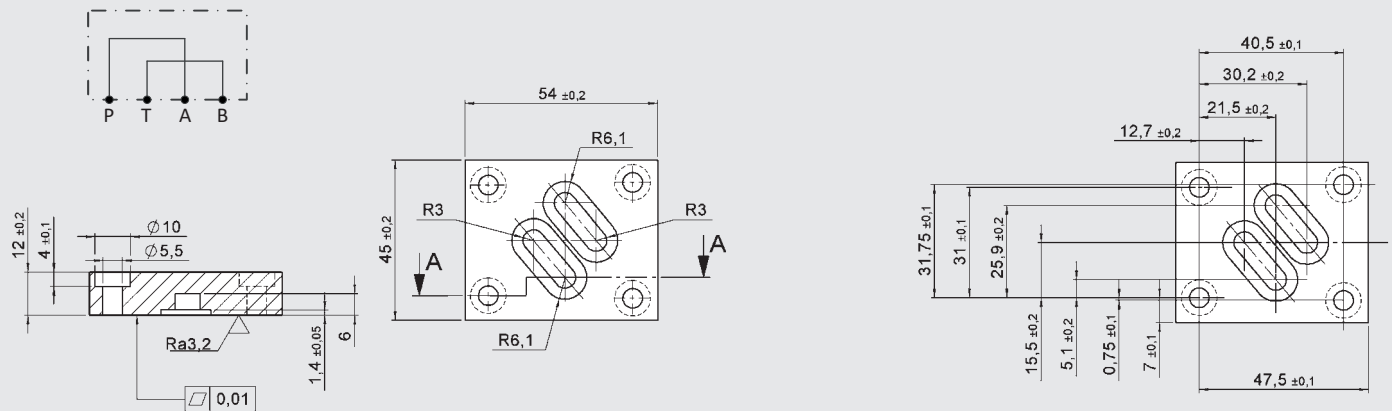

PBTA

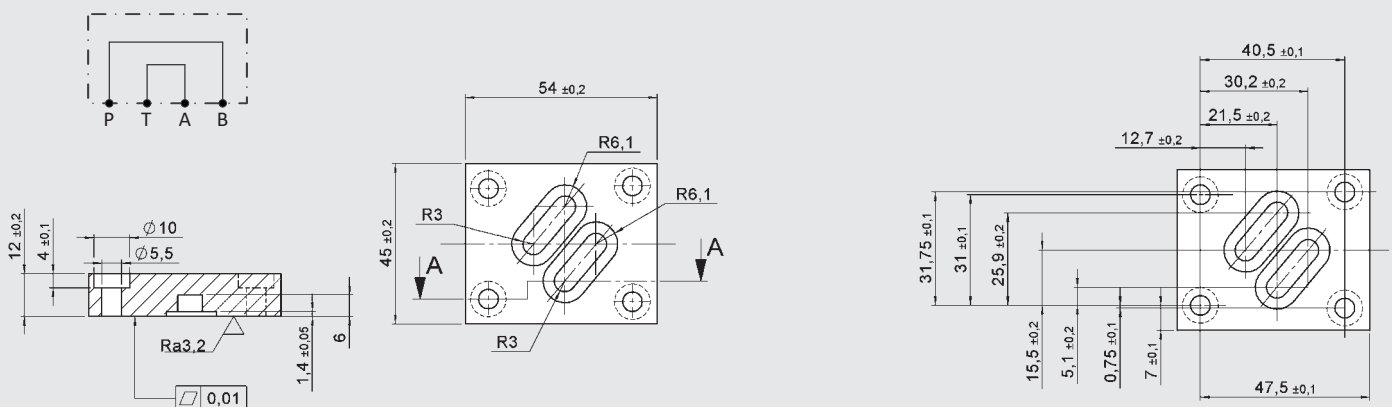

ACCESSORIES

	Designation	Part no.
Seal kits (6-part set)	22.22 x 2.62 -NBR -90 Sh (4 pieces)	3524553
	10.82 x 1.78 -NBR -90 Sh (2 pieces)	
	22.22 x 2.62 -FKM -90 Sh (4 pieces)	3524634
	10.82 x 1.78 -FKM -90 Sh (2 pieces)	
Mounting screws (6 pcs)	Screw set of M10x60 (4 pieces) and M6x50 (2 pieces)	3524695
Plug	M6x8 -45H	3524750
Plates	Check plate -NBR	3611576
	Check plate -FKM	3611580
	Interconnecting plate PATB -NBR	3581660
	Interconnecting plate PATB -FKM	3581661
	Interconnecting plate PBTA -NBR	3581662
	Interconnecting plate PBTA -FKM	3581663

Note

The information in this brochure relates to the operating conditions and applications described. For applications not described, please contact the relevant technical department. All technical details are subject to change without notice.

HYDAC Fluidtechnik GmbH
 Justus-von-Liebig-Str.
D-66280 Sulzbach/Saar
 Tel.: 0 68 97 /509-01
 Fax: 0 68 97 /509-598
 E-mail: valves@hydac.com

4/2- and 4/3-directional spool valve Hydraulically operated 4WH 25

DESCRIPTION

The 4WH valves in nominal size 25 are directional spool valves with hydraulic operation. They are used to control the start, stop and direction of a volume flow. A wide variety of spool types and options for opening control are available in this valve series.

FEATURES

- Hydraulically operated directional spool valve
- Electro-hydraulic operation via pilot valve NG 6 or hydraulic operation via interconnecting plate
- Flow rates up to 600 l/min
- The pilot supply and/or drain can be internal or external and can be achieved by changing the plug
- Interface according to ISO 4401-08



Nominal size 25
up to 600 l/min
up to 350 bar

CONTENTS

Description	_____
Features	_____
Model code	_____
Spool types / symbols	_____
Function	_____
Section view	_____
Technical data	_____
Performance	_____
Dimensions	_____
Accessories	_____

MODEL CODE

4WH E 25 G S01 /V /U

Type

4/2- or 4/3-directional spool valve, hydraulically operated

Control type

- E = external pilot drain and supply
- EI = external pilot supply, internal pilot drain
- I = internal pilot drain and supply (symbols G and H only with option G)
- IE = internal pilot supply, external pilot drain (symbols G and H only with option G)

Nominal size

25

Spool symbol ¹⁾

See page 80

Series

S01 = CETOP 4.2-4 P05-320 (Standard)

Sealing material

- N = NBR
- V = FKM (standard)

Options

Not specified = without interconnecting plate (standard)

- G = with check valve

¹⁾ Other models on request

SPOOL TYPES / SYMBOLS

4/2-DIRECTIONAL SPOOL VALVES

Type	Basic symbol	With intermediate position
C		
D		
Y		

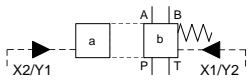

4/3-DIRECTIONAL SPOOL VALVES

Type	Basic symbol	With intermediate position
E		
G		
H		
J		

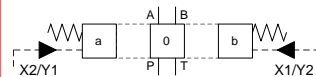

FUNCTION

The valves of the 4WH 25 series are directional spool valves with hydraulic operation which can control the start, stop and direction of a volume flow. They consist of the valve casing (1), the main control spool (2) and the return springs (3).

The fluid power supply of the valve is provided centrally via the standard porting pattern.

Without pilot oil, the main control spool is centred in its middle position by the springs. The actuation of the main control spool (2) is caused by pressurisation. The required pilot oil is provided by port X and Y or is controlled by an additional pilot valve that is adopted to the main valve. The pilot pressure depends on rate of flow. The minimal pilot pressure of 5 bar is sufficient only for low flow rates. Pilot pressure has to be increased up to 12 bar by increasing rates of volume flow. Pressure loading on one of the two front sides of the main control spool (2) with pilot pressure causes desired switching position, whereby the required ports will be linked. The spring, which is across from the pressurised control piston surface, causes the resetting of the piston into zero or initial position by relieving of pressure.

SECTION VIEW

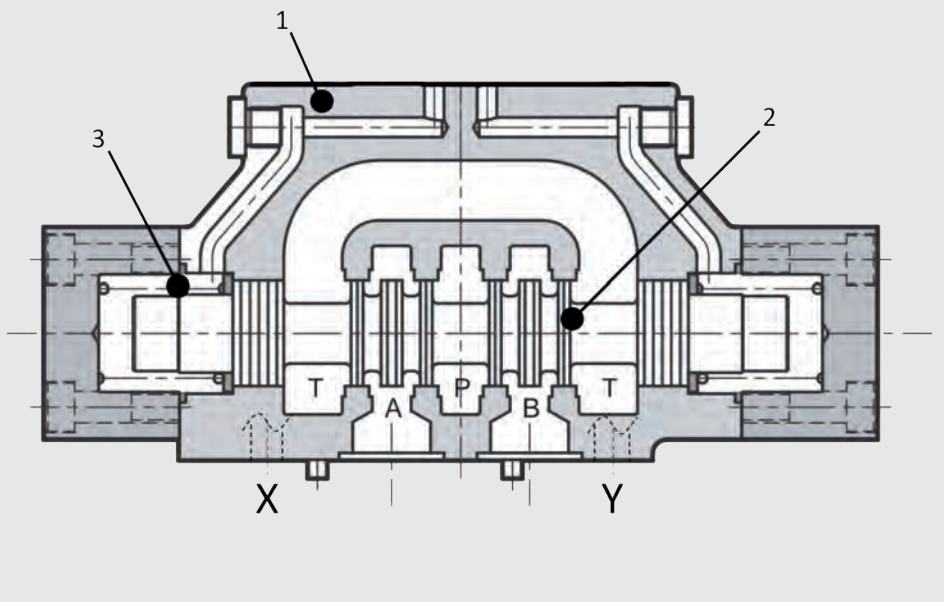

Control types – Pilot supply and pilot drain

If the valve is used as a hydraulically actuated valve, the pilot supply and pilot drain will occur external via port X and Y.

If the valve is used as the main stage in a pilot-operated valve, there are four possible control types for each basic valve. This can be seen in the model code.

The valve will be delivered correspondingly configured. Modification is possible afterwards. The glued threaded plugs will make disassembly more difficult.

- **Version "E"** – Pilot supply is external from a separate fluid power supply via port X. The pilot drain is also external via port Y.
- **Version "EI"** – Pilot supply is external from a separate fluid power supply via port X. The pilot drain is internal via port T.
- **Version "IE"** – Pilot supply is internal via port P. The pilot drain is external via port Y.
Hint: Symbols G and H only with option G.
- **Version "I"** – Pilot supply is internal via port P. The pilot drain is external via port T.
Hint: Symbols G and H only with option G.

TECHNICAL DATA ¹

General specifications	
MTTF _d :	According to EN ISO 13849-1:2015 chart C1 & C2
Ambient temperature range: [°C]	-20 to +50
Installation position:	No orientation restrictions
Weight: [kg]	15
Material:	Valve casing: Cast iron
	Name plate: Aluminium
Surface coating:	Valve casing: Phosphate plated

Hydraulic specifications	
Operating pressure: [bar]	350
Pilot pressure min: [bar]	5 to 12 ²
Pilot pressure max: [bar]	210
Nominal flow: [l/min]	600
Operating fluid:	Hydraulic oil to DIN 51524 Part 1, 2 and 3
Media operating temperature range: [°C]	-20 to +80
Viscosity range: [mm ² /s]	10 to 400
Permitted contamination level of operating fluid:	Class 20/18/15 according to ISO 4406
Sealing material:	FKM (standard), NBR

¹ see "Conditions and Instructions for Valves" in brochure 53.000

² Pilot pressure depends on rate of delivery flow. The minimal pilot pressure is sufficient only for low rates of delivery flow. As the rate of delivery flow increases, it is necessary to increase the pilot pressure up to the specified maximum value.

PERFORMANCE

Pressure drop

measured at $v = 36 \text{ mm}^2/\text{s}$, $T = 50 \text{ °C}$

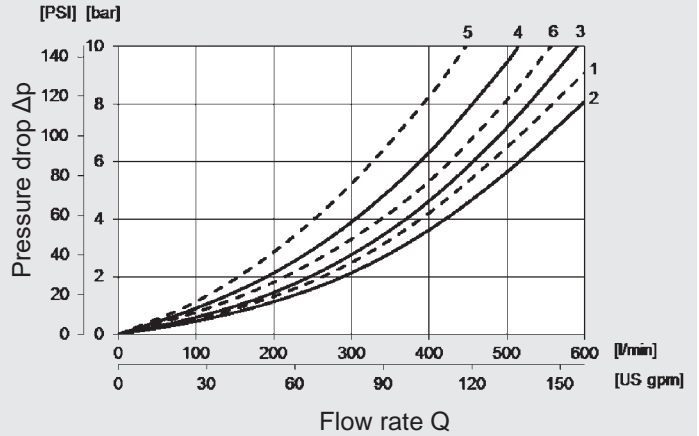

Performance limits

measured at $v = 36 \text{ mm}^2/\text{s}$, $T = 50 \text{ °C}$

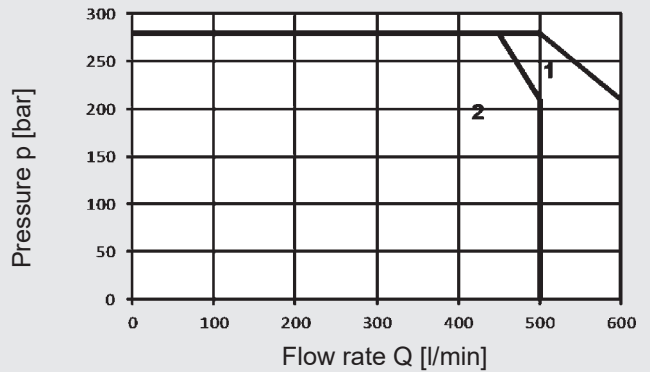

Performance assignment to the associated spools:

Spool	Switching position	Pressure drop					Performance limits
		P→A	P→B	A→T	B→T	P→T	
D	Not operated	1			3		1
	Operated		1	2			
E	Not operated						1
	Operated	1	1	2	3		
J	Not operated			4●	4○		1
	Operated	1	1	1	2		
H	Not operated					6**	1
	Operated	2	2	1	2		
G	Not operated					5	2
	Operated	6	6	3	4		

** A-B blocked ● B blocked ○ A blocked

DIMENSIONS

Interface according to ISO 4401-08-08-0-05 (CETOP 4.2-4-08-320)

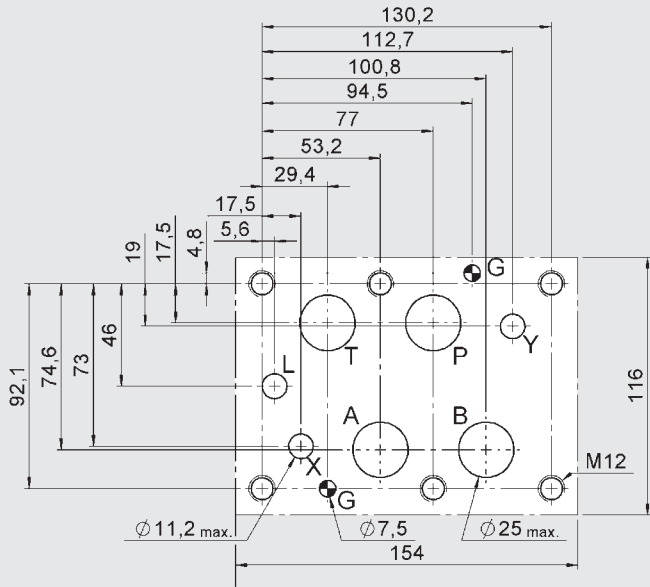

Mounting screws:

(not included in delivery)

6 Screws M12x60 ISO 4762

Tightening torque: 115 Nm (screws A 10.9)

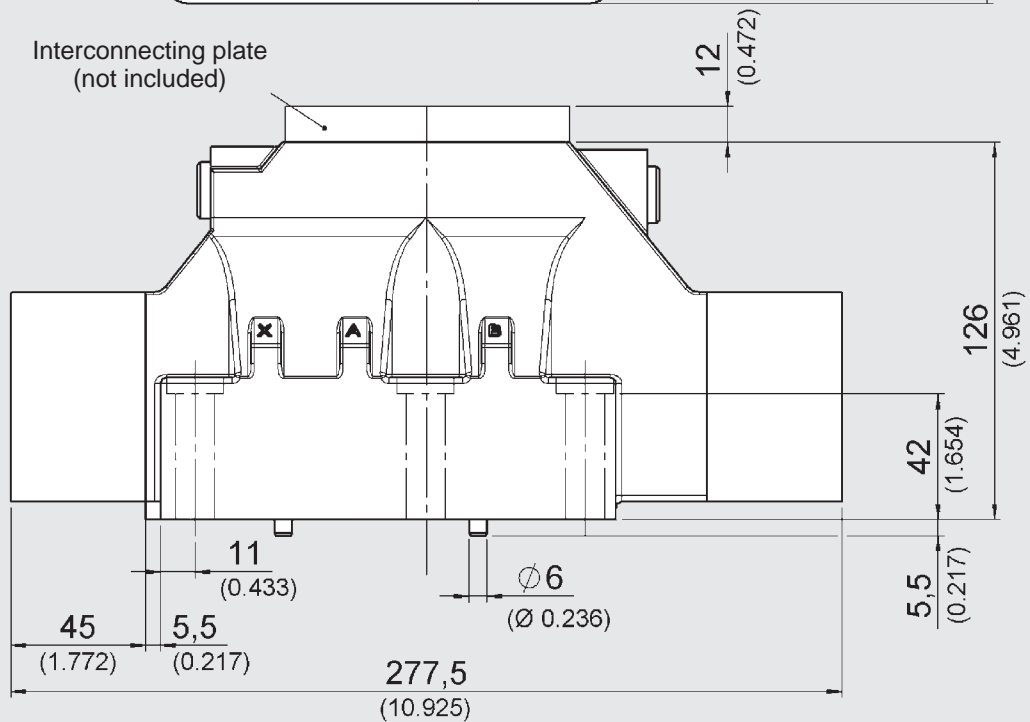
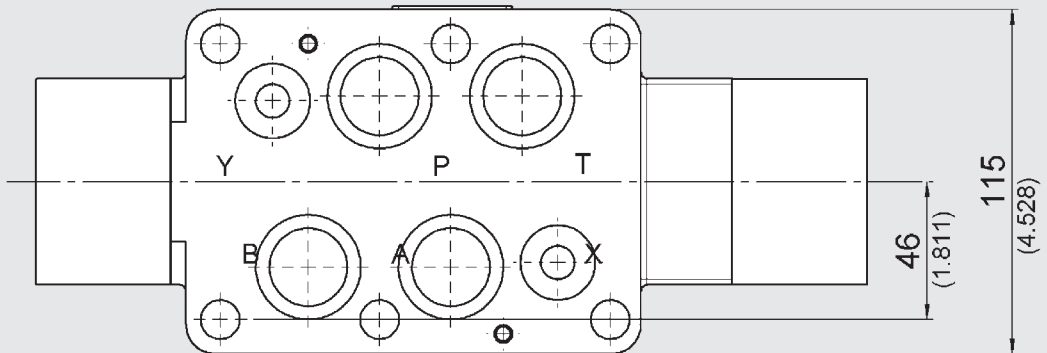

Plug

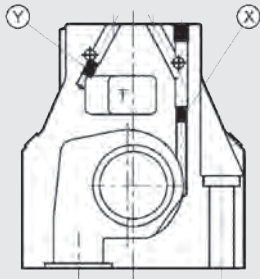

X: M6x8
for external pilot supply
Y: M6x8
for external pilot drain

Control type		Installation		Control
		X	Y	
E	external pilot drain and supply	•	•	hydraulically or pilot operated
EI	external pilot supply, internal pilot drain	•	–	pilot operated
I	internal pilot drain and supply	–	–	pilot operated
IE	internal pilot supply, external pilot drain	–	•	pilot operated

Plates

Check plate

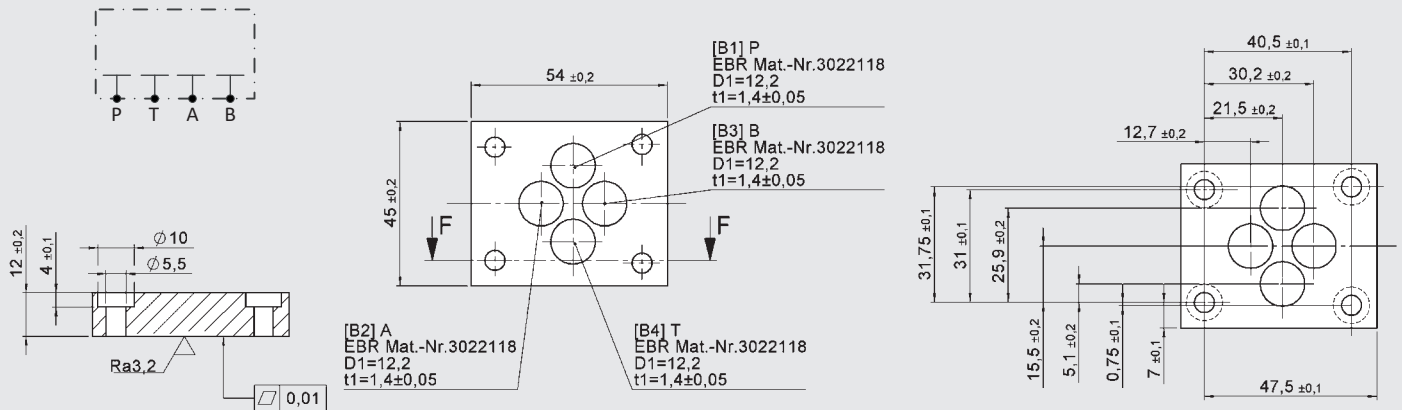

Interconnecting plates

PATB

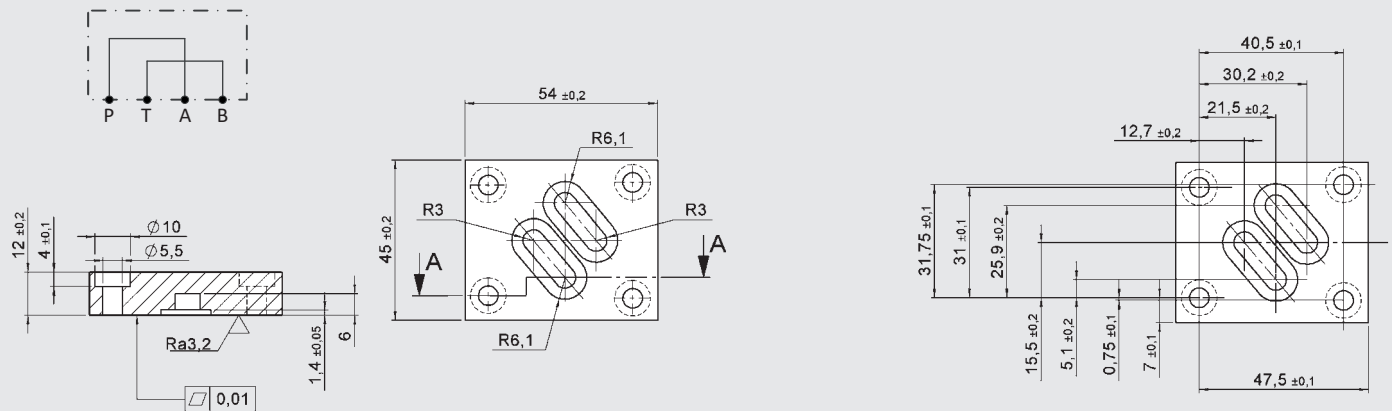

PBTA

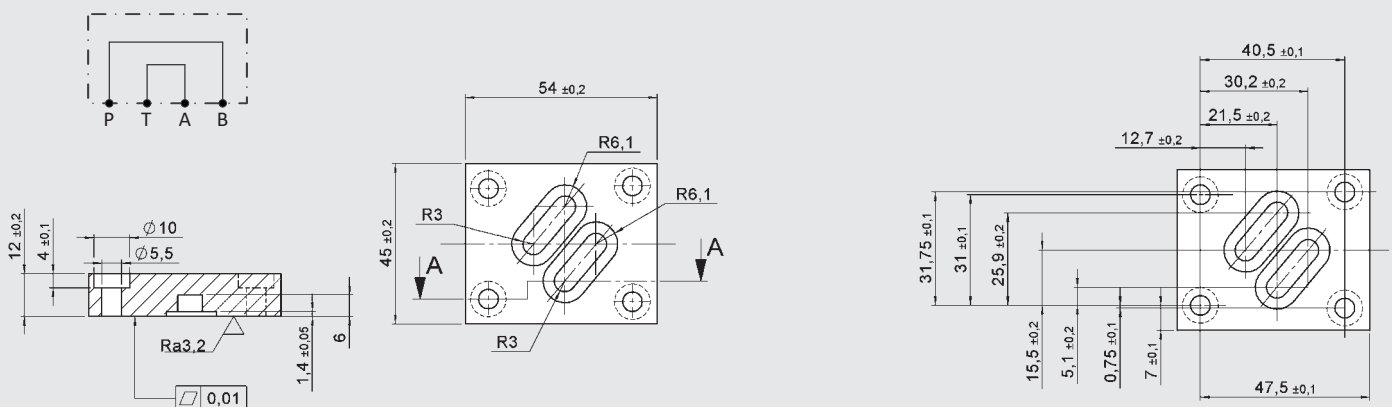

ACCESSORIES

	Designation	Part no.
Seal kits (6-part set)	29.82 x 2.62 -NBR -90 Sh (4 pieces)	3524659
	20.24 x 2.62 -NBR -90 Sh (2 pieces)	
	29.82 x 2.62 -FKM -90 Sh (4 pieces)	3524660
	20.24 x 2.62 -FKM -90 Sh (2 pieces)	
Mounting screws (6 pcs)	DIN EN ISO 4762-M12x60-10.9	3524698
Plug	M6x8 -45H	3524750
Plates	Check plate -NBR	3611576
	Check plate -FKM	3611580
	Interconnecting plate PATB -NBR	3581660
	Interconnecting plate PATB -FKM	3581661
	Interconnecting plate PBTA -NBR	3581662
	Interconnecting plate PBTA -FKM	3581663

Note

The information in this brochure relates to the operating conditions and applications described. For applications or operating conditions not described, please contact the relevant technical department.

Technical modifications are reserved.

HYDAC Fluidtechnik GmbH
 Justus-von-Liebig-Str.
D-66280 Sulzbach/Saar
 Tel.: 0 68 97 /509-01
 Fax: 0 68 97 /509-598
 E-mail: valves@hydac.com

4/2- and 4/3-directional spool valve Hydraulically operated 4WH 32

DESCRIPTION

The valves in nominal size 32 of the 4WH series are directional spool valves with hydraulic operation. They are used to control the start, stop and direction of the volume flow.

A wide variety of spool types and options for opening control are available in the context of the valve series.

FEATURES

- Hydraulically operated directional spool valve
- Electro-hydraulic operation via pilot valve NG 6 or hydraulic operation via interconnecting plate
- Flow rates up to 1000 l/min
- The pilot supply and/or drain can be internal or external and can be achieved by changing the plug
- Interface according to ISO 4401-10



Nominal size 32
up to 1000 l/min
up to 350 bar

CONTENTS

Description

Features

Model code

Spool types / symbols

Function

Section view

Technical data

Performance

Dimensions

Accessories

MODEL CODE

4WH E 32 G S01 V

Type

4/2- or 4/3-directional spool valve, hydraulically operated

Control type

- E = external pilot supply and drain
- EI = external pilot supply, internal pilot drain
- I = internal pilot supply and drain (not for symbol G and H)
- IE = internal pilot supply, external pilot drain (preload tank line: pressure between pilot and drain must be higher than the minimum pilot pressure)

Nominal size

32

Spool symbol ¹⁾

See page 88

Series

S01 = ISO 4401-10-09-0-05 (CETOP 4.2-4-10-350)

Sealing material

- N = NBR
- V = FKM (Standard)

¹⁾ Other models on request

SPOOL TYPES / SYMBOLS

4/2-DIRECTIONAL SPOOL VALVES

Type	Basic symbol	With intermediate position
D		

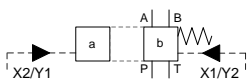

4/3-DIRECTIONAL SPOOL VALVES

Type	Basic symbol	With intermediate position
E		
G		
H		
J		

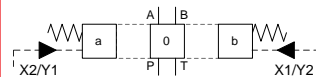

FUNCTION

The valves of the 4WH 32 type are directional spool valves with hydraulic operation which can control the start, stop and direction of the volume flow. They consist of the valve casing (1), the main control spool (2) and the return springs (3).

The fluid power supply of the valve is provided centrally via the standard porting pattern.

Without pilot oil, the main control spool is centred in its middle position by the springs. The actuation of the main control spool (2) is caused by pressurisation. The required pilot oil is provided by port X and Y or is controlled by an additional pilot valve that is adopted to the main valve. The pilot pressure depends on rate of volume flow. The minimal pilot pressure of 5 bar is sufficient only for low rates of flow. Pilot pressure has to be increased up to 12 bar by increasing rates of volume flow.

Pressure loading on one of the two front sides of the main control spool (2) with pilot pressure causes desired switching position, whereby the required ports will be linked.

The spring, which is across from the pressurised control piston surface, causes the resetting of the piston into zero or initial position by relieving of pressure.

SECTION VIEW

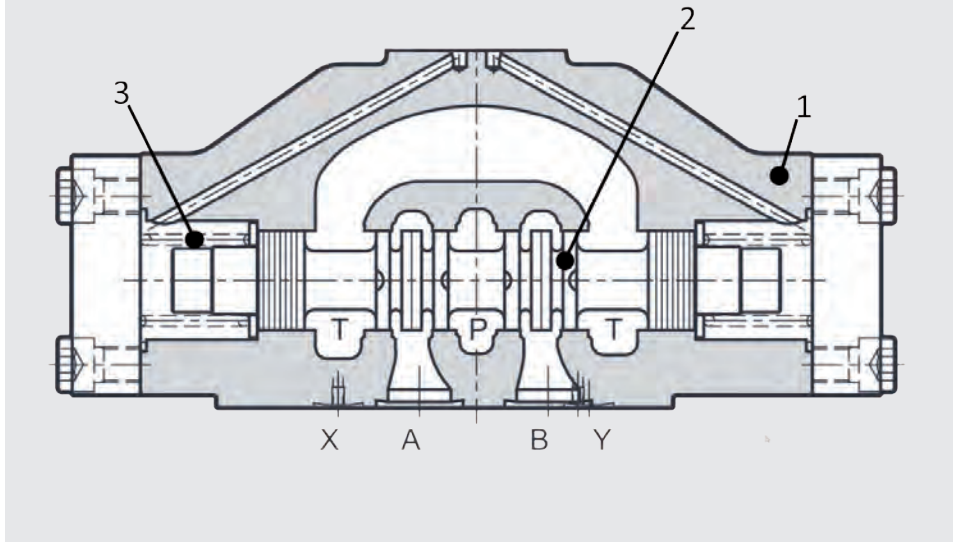

Control types – Pilot supply and pilot drain

If the valve is used as a hydraulically actuated valve, then the pilot supply and drain will occur externally via port X and Y.

If the valve is used as main stage in a pilot-operated valve, there are four possible control types for each basic valve. This can be seen in the model code.

The valve will be delivered correspondingly configured. Modification is possible afterwards. The glued threaded plugs will make disassembly more difficult.

- **Version "E"** – Pilot supply is external from a separate fluid power supply via port X. The pilot drain is also external via port Y.
- **Version "EI"** – Pilot supply is external from a separate fluid power supply via port X. The pilot drain is internal via port T.
- **Version "IE"** – Pilot supply is internal via port P. The pilot drain is external via port Y.
Hint: Preload tank line - pressure between pilot and drain must be higher than the minimum pilot pressure.
- **Version "I"** – Pilot supply is internal via port P. The pilot drain is internal via port T.
Hint: Not for symbol G and H.

TECHNICAL DATA ¹

General specifications	
MTTF _d :	According to EN ISO 13849-1:2015 chart C1 & C2
Ambient temperature range: [°C]	-20 to +50
Installation position:	No orientation restrictions
Weight: [kg]	48.0
Material:	Valve casing: Cast iron
	Name plate: Aluminium
Surface coating:	Valve casing: Phosphate plated
Hydraulic specifications	
Operating pressure: [bar]	Port A, B, P: $p_{max} = 350$
	Port T: $p_{max} = 210$
Pilot pressure min: [bar]	6 to 12 ²
Pilot pressure max: [bar]	280
Nominal flow: [l/min]	1000
Operating fluid:	Hydraulic oil to DIN 51524 Part 1, 2 and 3
Media operating temperature range: [°C]	-20 to +80
Viscosity range: [mm ² /s]	10 to 400
Permitted contamination level of operating fluid:	Class 20/18/15 according to ISO 4406
Sealing material:	FKM (standard), NBR

¹ see "Conditions and Instructions for Valves" in brochure 53.000

² Pilot pressure depends on rate of delivery flow. The minimal pilot pressure is sufficient only for low rates of delivery flow. If the rate of delivery flow increases, it is necessary to increase the pilot pressure up to the specified maximum value.

PERFORMANCE

Pressure drop

measured at $v = 36 \text{ mm}^2/\text{s}$, $T = 50 \text{ °C}$

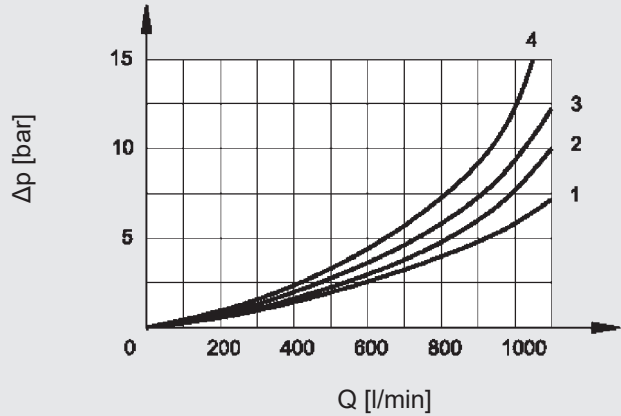

Performance limits

measured at $v = 36 \text{ mm}^2/\text{s}$, $T = 50 \text{ °C}$

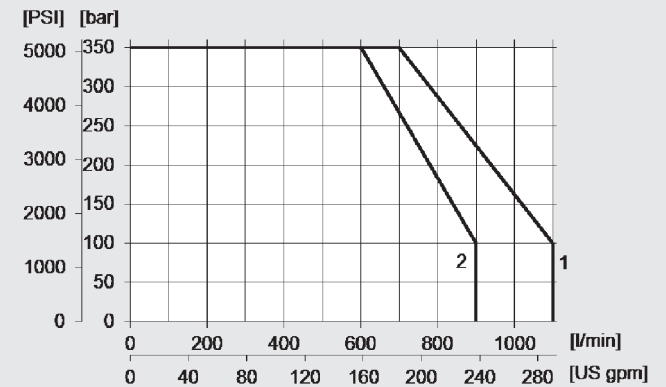

Performance assignment to the associated spools:

Spool	Switching position	Pressure drop					Performance limits
		P-A	P-B	A-T	B-T	P-T	
D	Not operated	1				1	1
	Operated		1	1			
E	Not operated						1
	Operated	1	1	1	1		
J	Not operated			4●	4○		1
	Operated	1	1	4	4		
H	Not operated					3**	2
	Operated	2	2	2	2		
G	Not operated					4	2
	Operated	2	2	2	2		

** A-B blocked ● B blocked ○ A blocked

DIMENSIONS

Interface according to ISO 4401-10-09-0-05 (CETOP 4.2-4-10-350)

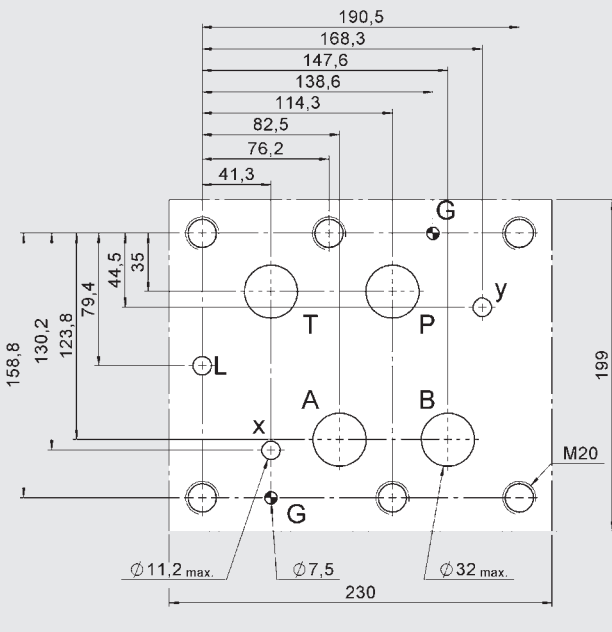

Mounting screws:

(not included in delivery)

6 screws M20x70 ISO 4762

Tightening torque: 560 Nm (screws A 10.9)

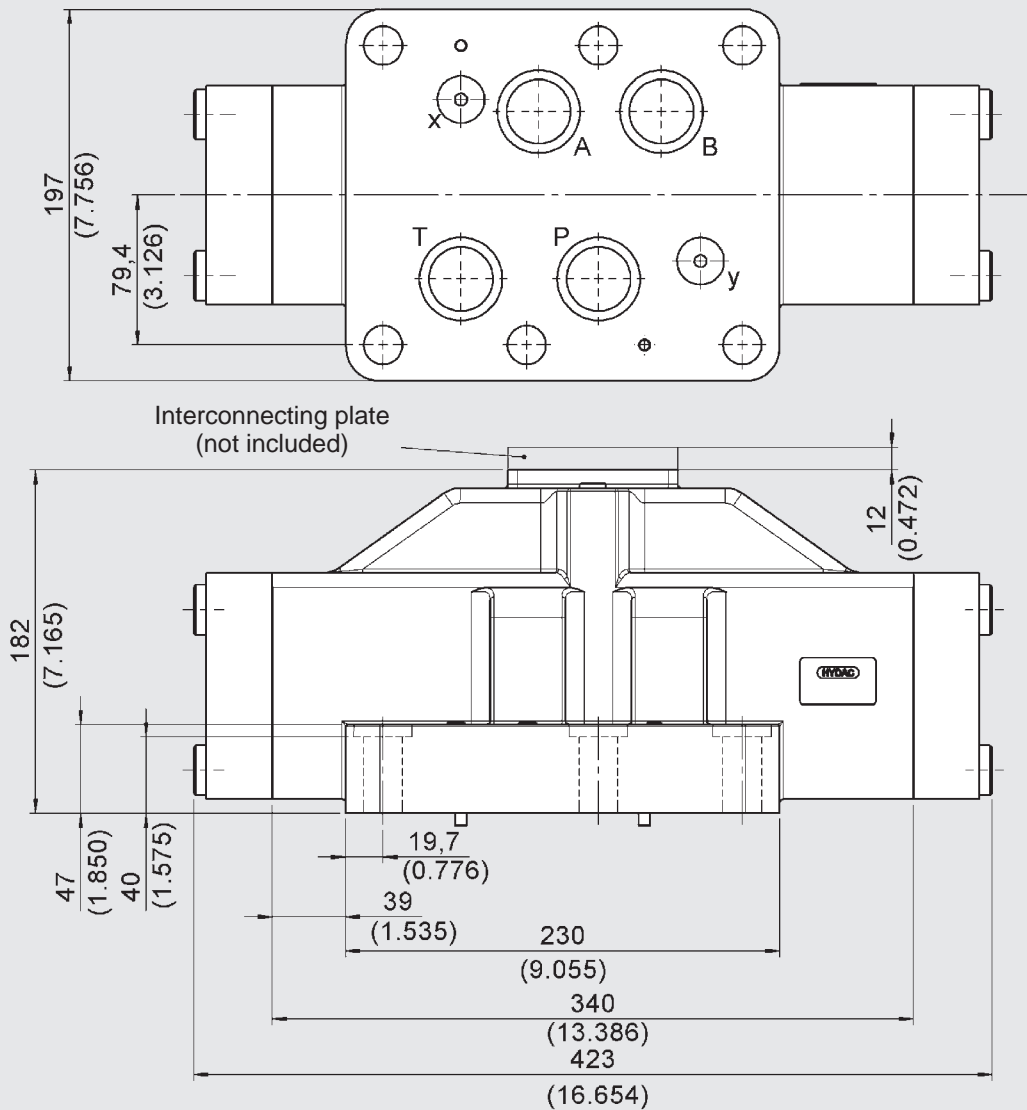

Plug

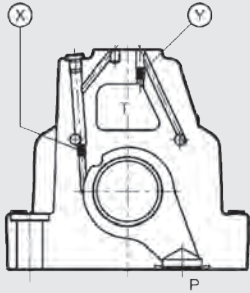

X: M6x8
for external pilot supply
Y: M6x8
for external pilot drain

Control type		Installation		Control
		X	Y	
E	External pilot drain and supply	•	•	hydraulically or pilot operated
EI	External pilot supply, internal pilot drain	•	–	pilot operated
I	Internal pilot drain and supply	–	–	pilot operated
IE	Internal pilot supply, external pilot drain	–	•	pilot operated

Plates

Check plate

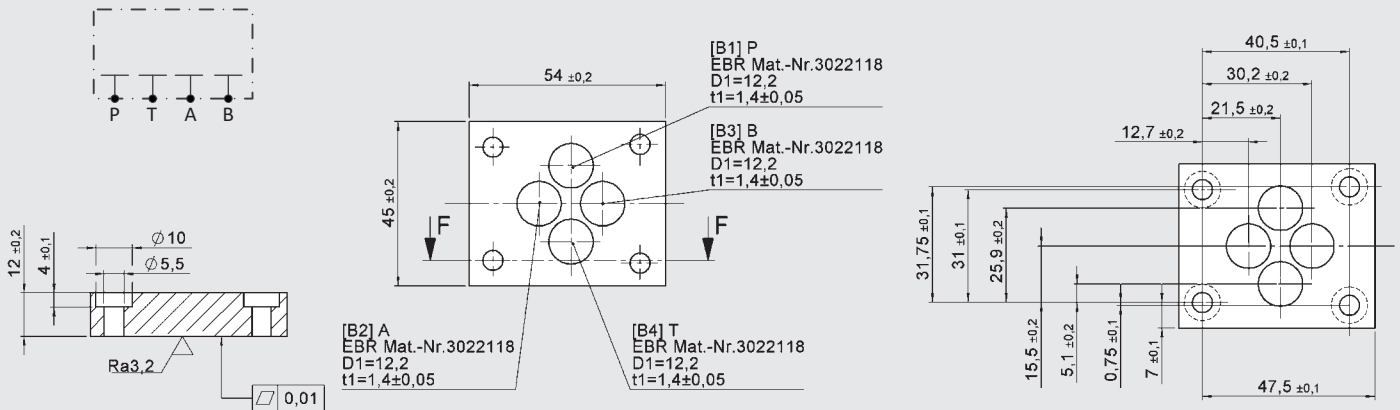

Interconnecting plates

PATB

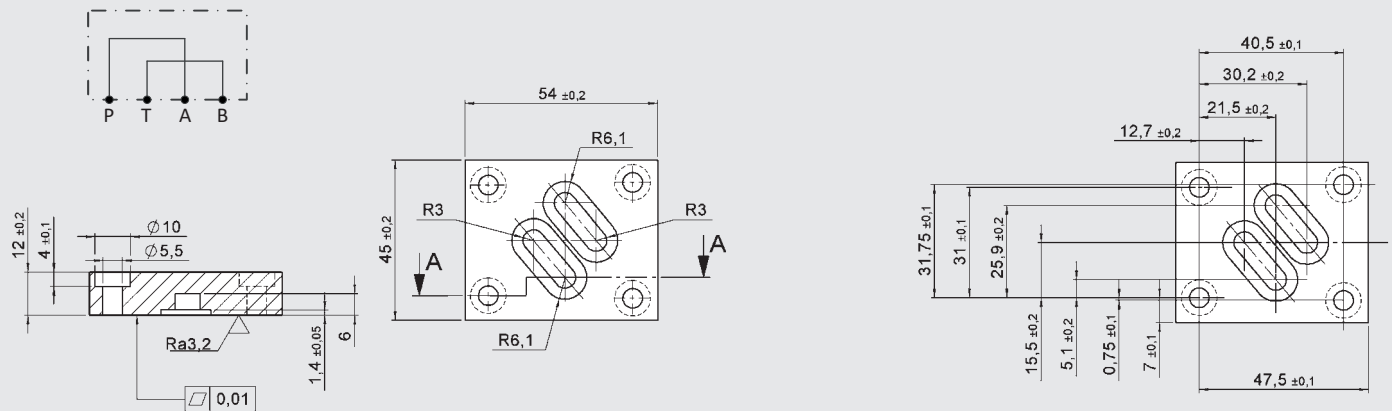

PBTA

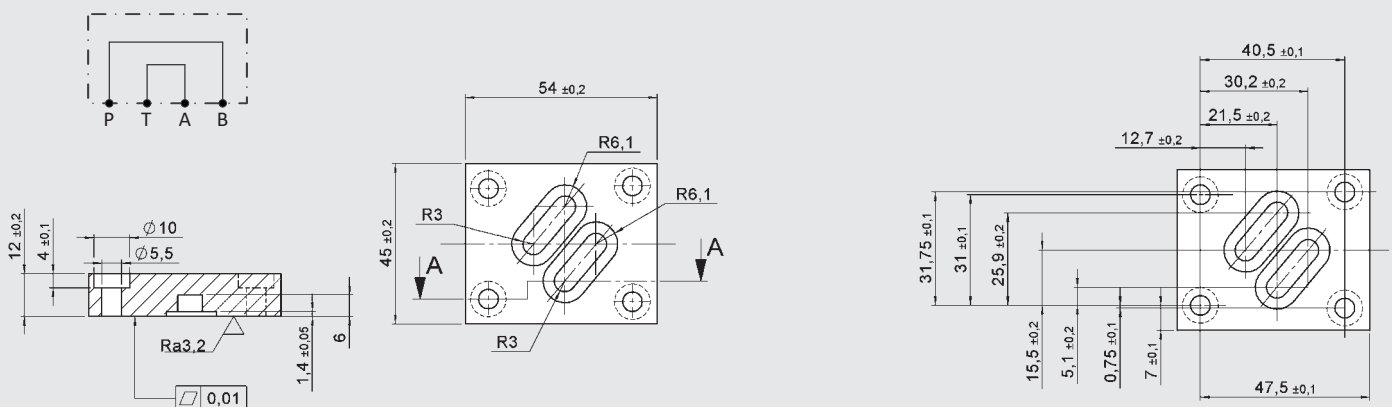

ACCESSORIES

	Designation	Part no.
Seal kits (6-part set)	37.59 x 3.53 -NBR -90 Sh (4 pieces)	3524685
	20.24 x 2.62 -NBR -90 Sh (2 pieces)	
	37.59 x 3.53 -FKM -90 Sh (4 pieces)	3524690
	20.24 x 2.62 -FKM -90 Sh (2 pieces)	
Mounting screws (4 pcs)	DIN EN ISO 4762-M20x70-10.9	3524700
Plug	M6x8 -45H	3524750
Plates	Check plate -NBR	3611576
	Check plate -FKM	3611580
	Interconnecting plate PATB -NBR	3581660
	Interconnecting plate PATB -FKM	3581661
	Interconnecting plate PBTA -NBR	3581662
	Interconnecting plate PBTA -FKM	3581663

Note

The information in this brochure relates to the operating conditions and applications described. For applications not described, please contact the relevant technical department. All technical details are subject to change without notice.

HYDAC Fluidtechnik GmbH
 Justus-von-Liebig-Str.
D-66280 Sulzbach/Saar
 Tel.: 0 68 97 /509-01
 Fax: 0 68 97 /509-598
 E-mail: valves@hydac.com

4/2- and 4/3-directional spool valve pilot operated 4WEH 10 to 32

DESCRIPTION

HYDAC 4/2- and 4/3- directional valves of the 4WEH series are pilot operated spool valves, which control start, stop and direction of a volume flow.

The pilot valve operates by oil-immersed solenoid. During this process, the solenoid pushes the pilot valve's control spool into the respective position.

By actuating the solenoid, the pilot flow rate is controlled, so the piston of the the main stage moves whereby the the desired flow paths can be switched.

A wide variety of spool types and options for opening control are available in this valve series.

FEATURES

- Pilot operated, solenoid-operated directional valve
- Electro-hydraulic operation via pilot valve NG 06
- Flows from 150 to 1000
- The pilot supply or drain can be internal or external, which can be achieved by changing the plugs
- Easy interchangeability via standardised to ISO 4401



CONTENT

Description
Features
Model code
Spool types / Symbols
Technical data
Function
Section view
Performance
Dimensions
Electrical connections
Manual overrides
Accessories

MODEL CODE

4WEH E 10 D S01 – 24 D G /V /M1 /D

Type

Solenoid-operated directional valve with 4 main ports,
hydraulically operated, pilot operated

Control type

E = external pilot supply and drain

EI = external pilot supply, internal pilot drain

I = internal pilot supply and drain

IE = internal pilot supply, external pilot drain

(preload tank line: pressure between pilot and drain must be more
than minimum pilot pressure)

Nominal size (NG)

10, 16, 25, 32

Symbols¹

see chapter „Spool types / Symbols“

Series

S01 = standard interface see “Dimensions”

S02 = ISO 4401-05-05-0-05 (NG10 only)

Rated voltage of the solenoid coil¹

12 = 12 VDC

24 = 24 VDC

96 = 96 VDC*

205 = 205 VDC*

110 = 110 VAC*

230 = 230 VAC*

* only in combination with the electrical connection G

Type of voltage

D = DC voltage

A = AC voltage (only in combination with electrical connection G)

Electrical connection (for details see chapter „Electrical connections“)

G = device connector, DIN EN 175301-803 A

L = single leads

N = device connector, Deutsch

O = device connector, M12

U = device connector, Junior Timer

Sealing material

V = FKM (standard)

N = NBR

Manual override

Not specified = with concealed manual override (standard)

/M... = see chapter „Manual overrides“

Options

Not specified = without option (standard)

G = with check valve (NG16 and NG25 only)

D = with pressure reducing valve type ZW-DM06, fixed setting to 30 bar

SZ = Switching time setting as meter-in control

SA = Switching time setting as meter-out control

/YXX = orifice insert: Y = port P, A, B, T

XX = diameter (e.g. 12 = 1,2 mm)

¹ other models on request

SPOOL TYPES / SYMBOLS

4/2-DIRECTIONAL SPOOL VALVES

Type	Symbol with intermediate position
D	
C	
Y	
EA	
EB	
GA	
HA	
JA	
QA	

With detent (...-OF)

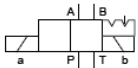

4/3-DIRECTIONAL SPOOL VALVES

Type	Symbol with intermediate position
E	
G	
H	
J	
Q	
L	

TECHNICAL DATA ¹

General specifications

	Nominal size			
	10	16	25	32
MTTF _d :	To EN ISO 13849-1:2015 chart C1 & C2			
Ambient temperatures range: [°C]	-20 to +50			
Installation position:	No orientation restrictions			
Weight main stage: [kg]	5,0	6,6	15	48,0
Weight Pilot: [kg]	1,5 with one solenoid; 2,0 with two solenoids			
Material:	Valve casing:	Bast iron		
	Pole tube	Steel		
	Coil casing:	Steel		
	Name plate:	Aluminium		
Surface coating:	Valve casing:	Phosphate plated		
	Pole tube	Zn-coating		
	Coil casing:	Zn-Ni-coating		

Hydraulic specifications

	Nominal size			
	10	16	25	32
Operating pressure port A, B, P: [bar]	$p_{max} = 320$	$p_{max} = 350$		
	Port T, internal leak port:		$p_{max} = 210$	
	Port T, external leak port:		$p_{max} = 210$	
Control pressure: [bar]	$p_{min} = 5$ to 12^3			$p_{min} = 6$ to 12^3
	$p_{max} = 210$			$p_{max} = 280$
Max. flow: [l/min]	150	300	600	1000
Operating fluid:	Hydraulic oil to DIN 51524 part 1, 2 and 3			
Media operating temp. range: [°C]	-20 to +80			
Viscosity range: [mm ² /s]	10 – 400			
Permitted contamination level of operating fluid:	class 20/18/15 to ISO 4406			
Sealing material:	NBR, FKM (standard)			

Electrical specifications

	Nominal size			
	10	16	25	32
Switching-time energized: [ms]	50	60	70	100
Switching-time de-energized: [ms]	40	45	50	60
Type of voltage and rated voltage: [V]	DC: 12, 24, 96, 205			
	AC: 110, 230			
Voltage tolerance: [%]	±10			
Nominal power: [W]	30			
Duty cycle: [%]	100			
Max. surface temperature of the coil: [°C]	150			
Protection class according to DIN EN 60529:	with electrical connection "G"	IP65 ²		
	with electrical connection "L"	IP65 ²		
	with electrical connection "N"	IP65 / IP67 ²		
	with electrical connection "O"	IP65 ²		
	with electrical connection "U"	IP65 ²		

¹ see „Conditions and Instructions for Valves“ in brochure 53.000

² if installed correctly

³ Pilot pressure depends on rate of delivery flow. The minimal pilot pressure is sufficient only for low rates of delivery flow. If the rate of delivery flow increases, it is necessary to increase the pilot pressure up to the specified maximum value

FUNCTION

The valves of the 4WEH series are hydraulic pilot operated directional spool valves, which can control start, stop and direction of a volume flow. They essentially consist of a pilot valve NG6 (1) and a main stage (2).

The fluid power supply of the valve is provided centrally via standard porting pattern. Without pilot oil, the main control spool is centered in its middle position by the springs. The actuation of the main control spool is caused by the pilot valve. The control pressure is dependent on the flow rate. The minimal control pressure of 5 bar is only sufficient for low flow rates. Pilot pressure has to be increased up to 12 bar by increasing flow rates. Pressure loading on one of the two front sides of the main control spool with pilot pressure causes the desired switching position, whereby the required ports will be linked.

The spring, which is across from the pressurised control piston surface, causes the resetting of the piston into zero or initial position by relieving of pressure.

If the control is external, port X and Y take the oil supply or the relief of the pilot circuit to the tank level. Port Y is used for pilot oil drain and is usually discharged into the tank without pressure (leak port).

The standard interface differ in the respective nominal sizes and are not compatible.

SECTION VIEW

Example 4WEH10

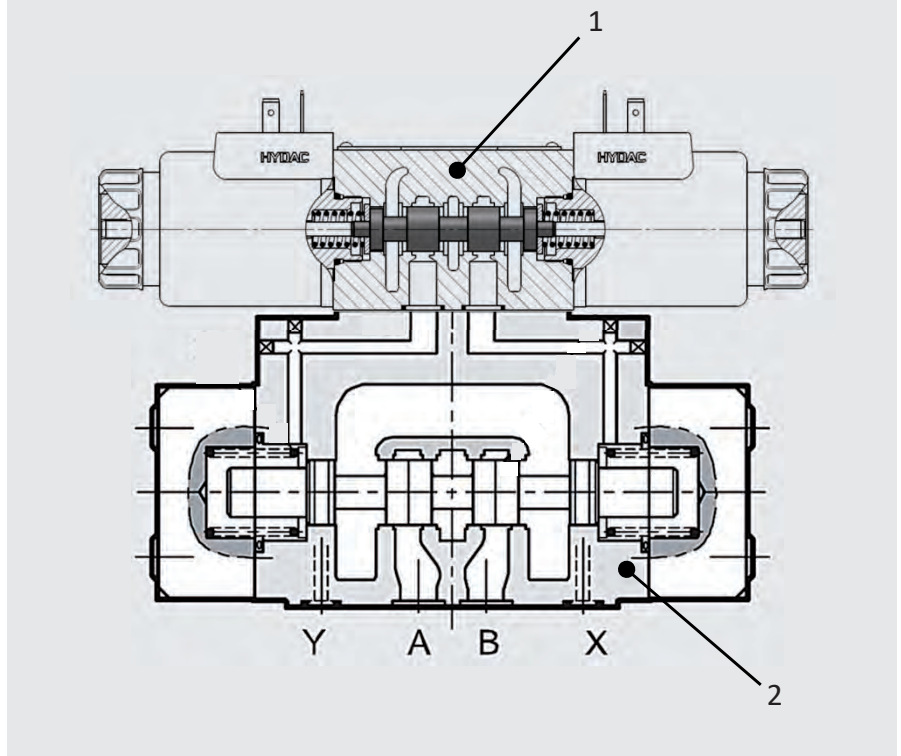

Control types – Pilot oil supply and pilot oil drain

If the valve is used as a hydraulic actuated valve, the pilot oil supply and pilot oil drain will occur externally via port X and Y.

There are four possible control types. This can be seen in the model code.

The valve will be factory-set configured and delivered corresponding to the model code. The threaded plugs are glued. Subsequent modification is not recommended.

Version „E“

Pilot supply is external from a separate fluid power supply via port X. The pilot drain is also external via port Y.

Version „EI“

Pilot supply is external from a separate fluid power supply via port X. The pilot drain is internal via port T.

Version „IE“

Pilot supply is internal via port P. The pilot drain is external via port Y.

Hint: Preload tank line - Pressure between pilot and drain must be more than minimum pilot pressure

Version „I“

Pilot supply is internal via port P. The pilot drain is internal via port T.

Hint: NG10 and NG32: Not for symbol G and H.

NG16 and NG25: Symbol G and H only with option G.

PERFORMANCE NG10

Pressure drop

measured at $v = 36 \text{ mm}^2/\text{s}$, $T = 50 \text{ }^\circ\text{C}$

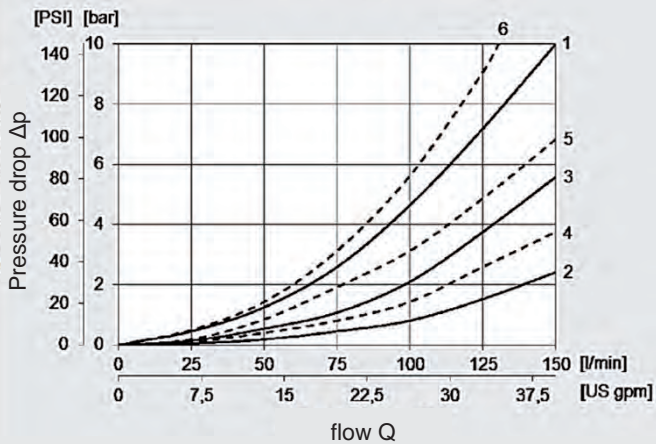

Performance limits

measured at $v = 36 \text{ mm}^2/\text{s}$, $T = 50 \text{ }^\circ\text{C}$

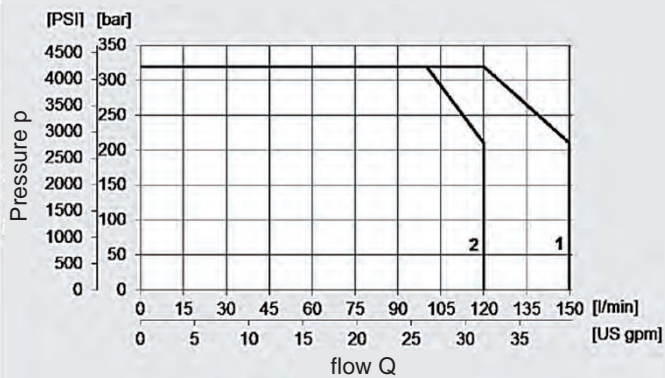

Performance assignment to the associated spools

Spool	Switching position	Pressure drop					Performance limits
		P→A	P→B	A→T	B→T	P→T	
D	not operated	1			3		1
	operated		1	4			
E	not operated						1
	operated	1	1	2	3		
G	not operated					6	2
	operated	6	6	3	5		
H	not operated					6*	1
	operated	5	5	2	4		
J	not operated			1●	1○		1
	operated	1	1	2	4		
Q	not operated						1
	operated	1	1	2	2		

* A-B blocked ● B blocked ○ A blocked

PERFORMANCE NG16

Pressure drop

measured at $v = 36 \text{ mm}^2/\text{s}$, $T = 50 \text{ }^\circ\text{C}$

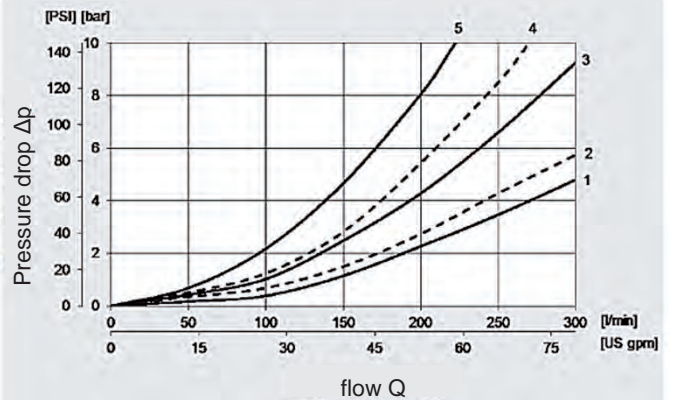

Performance limits

measured at $v = 36 \text{ mm}^2/\text{s}$, $T = 50 \text{ }^\circ\text{C}$

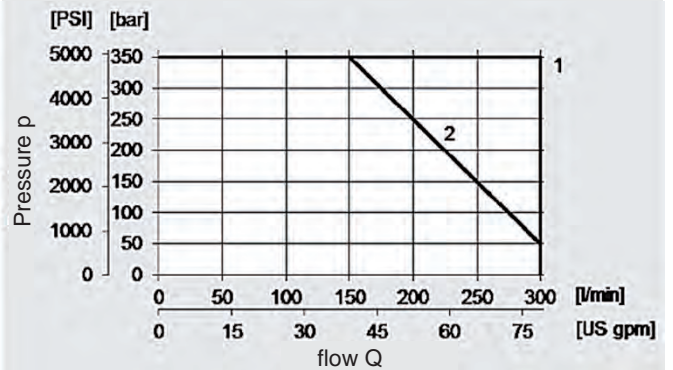

Performance assignment to the associated spools

Spool	Switching position	Pressure drop					Performance limits
		P→A	P→B	A→T	B→T	P→T	
C	Not operated	1			4		1
	Operated		1	4			
D	Not operated	1			4		1
	Operated		1	3			
E	Not operated						1
	Operated	1	1	3	4		
J	Not operated			4●	4○		1
	Operated	1	1	4	4		
H	Not operated					2**	1
	Operated	1	1	4	4		
G	Not operated					4	2
	Operated	2	2	4	5		
L	Not operated			4			1
	Operated	1	1	3	4		
Q	Not operated						1
	Operated	1	1	3	4		
Y	Not operated		1	3			1
	Operated	1			4		

** A-B blocked ● B blocked ○ A blocked

PERFORMANCE NG25

Pressure drop

measured at $v = 36 \text{ mm}^2/\text{s}$, $T = 50 \text{ }^\circ\text{C}$

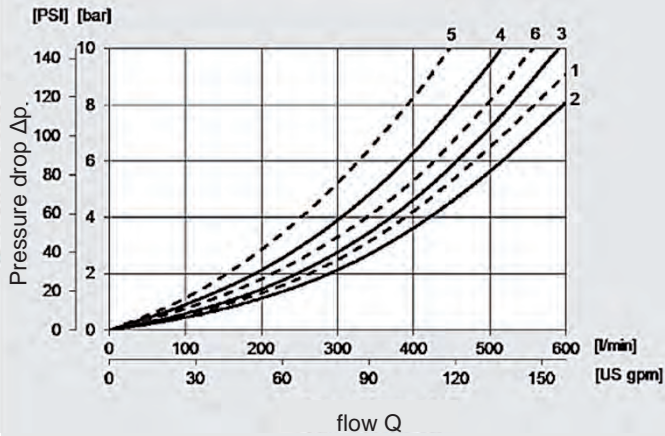

Performance limits

measured at $v = 36 \text{ mm}^2/\text{s}$, $T = 50 \text{ }^\circ\text{C}$

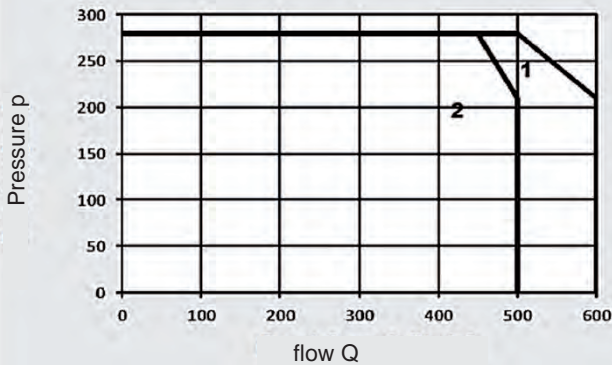

Performance assignment to the associated spools

Spool	Switching position	Pressure drop					Performance limits
		P-A	P-B	A-T	B-T	P-T	
D	Not operated	1			3		1
	Operated		1	2			
E	Not operated						1
	Operated	1	1	2	3		
J	Not operated			4●	4○		1
	Operated	1	1	1	2		
H	Not operated					6**	1
	Operated	2	2	1	2		
G	Not operated					5	2
	Operated	6	6	3	4		

** A-B blocked ● B blocked ○ A blocked

PERFORMANCE NG32

Pressure drop

measured at $v = 36 \text{ mm}^2/\text{s}$, $T = 50 \text{ }^\circ\text{C}$

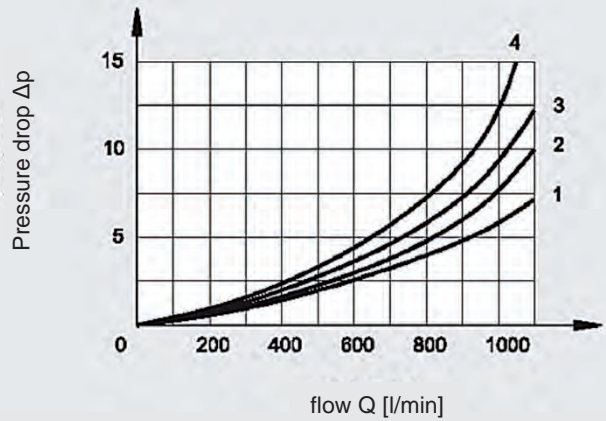

Performance limits

measured at $v = 36 \text{ mm}^2/\text{s}$, $T = 50 \text{ }^\circ\text{C}$

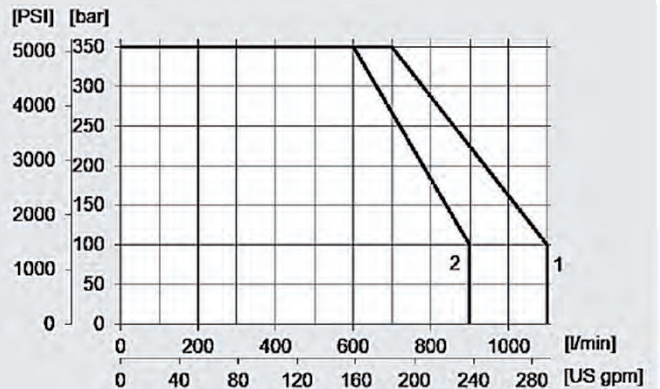

Performance assignment to the associated spools

Spool	Switching position	Pressure drop					Performance limits
		P-A	P-B	A-T	B-T	P-T	
D	Not operated	1			1		1
	Operated		1	1			
E	Not operated						1
	Operated	1	1	1	1		
J	Not operated			4●	4○		1
	Operated	1	1	4	4		
H	Not operated					3**	2
	Operated	2	2	2	2		
G	Not operated					4	2
	Operated	2	2	2	2		

** A-B blocked ● B blocked ○ A blocked

DIMENSIONS NG10

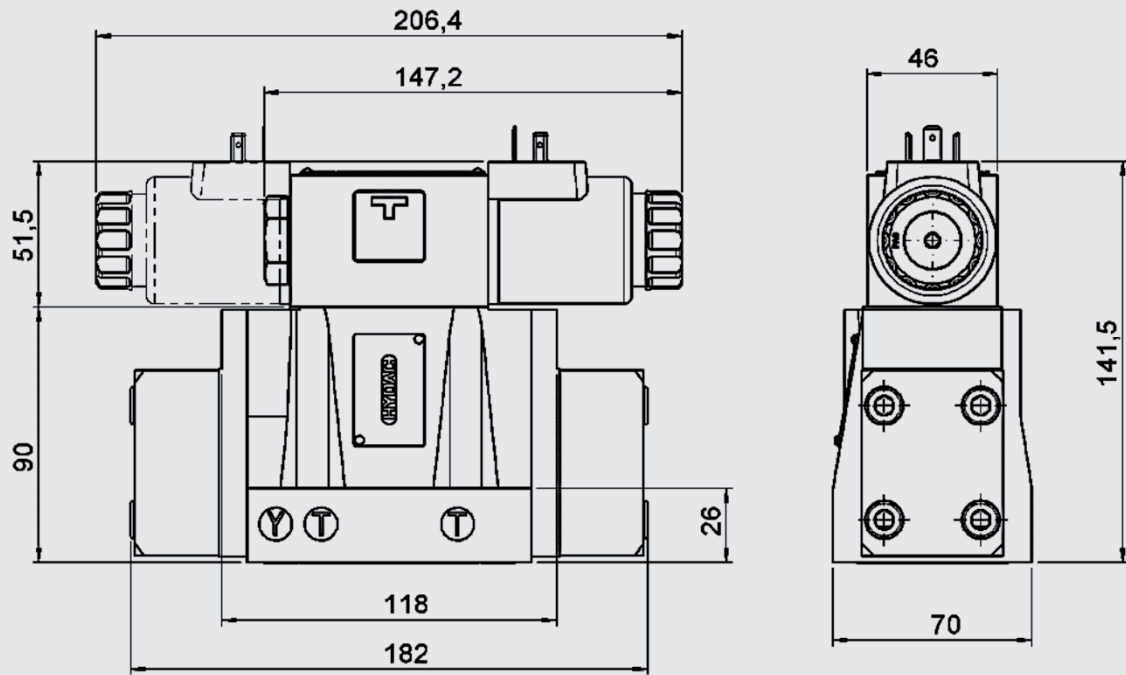

with option D and SZ

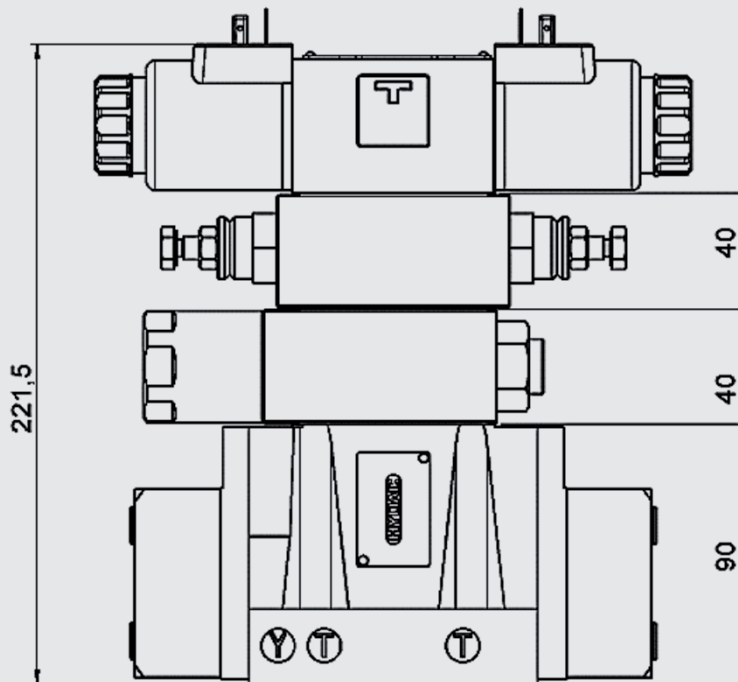

Mounting screws:
(not included in delivery)
4 screws (A10.9) M6x35 ISO4762
Torque: 12 Nm

DIMENSIONS NG16

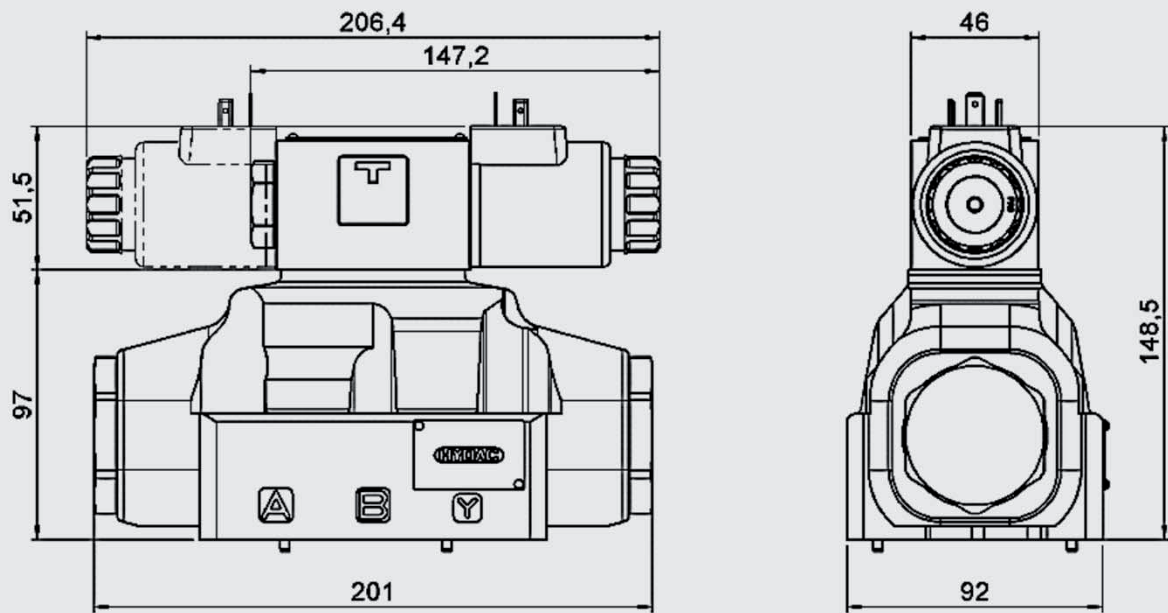

with option D and SZ

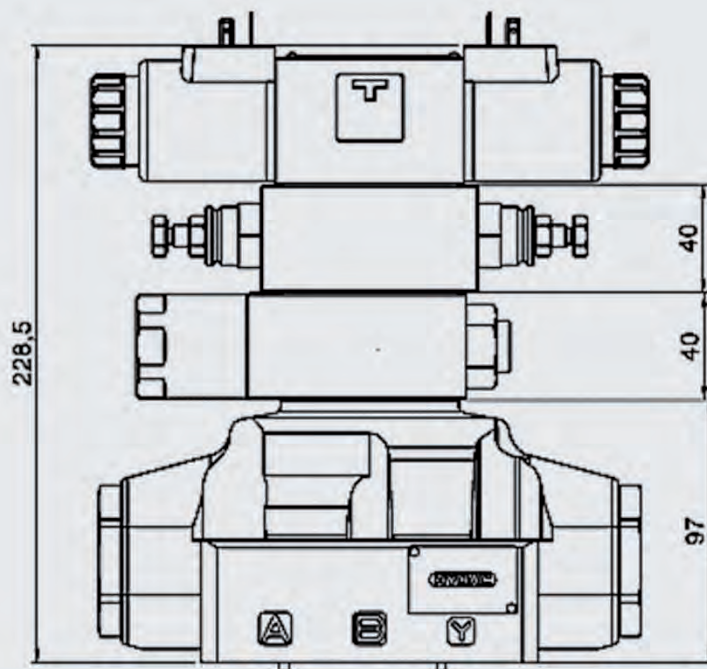

Mounting screws:

(not included in delivery)

4 screws (A10.9) M10x60 and

2 screws (A10.9) M6x50 ISO4762

Torque:

M10x60: 57 Nm and M6x50: 14 Nm

DIMENSIONS NG25

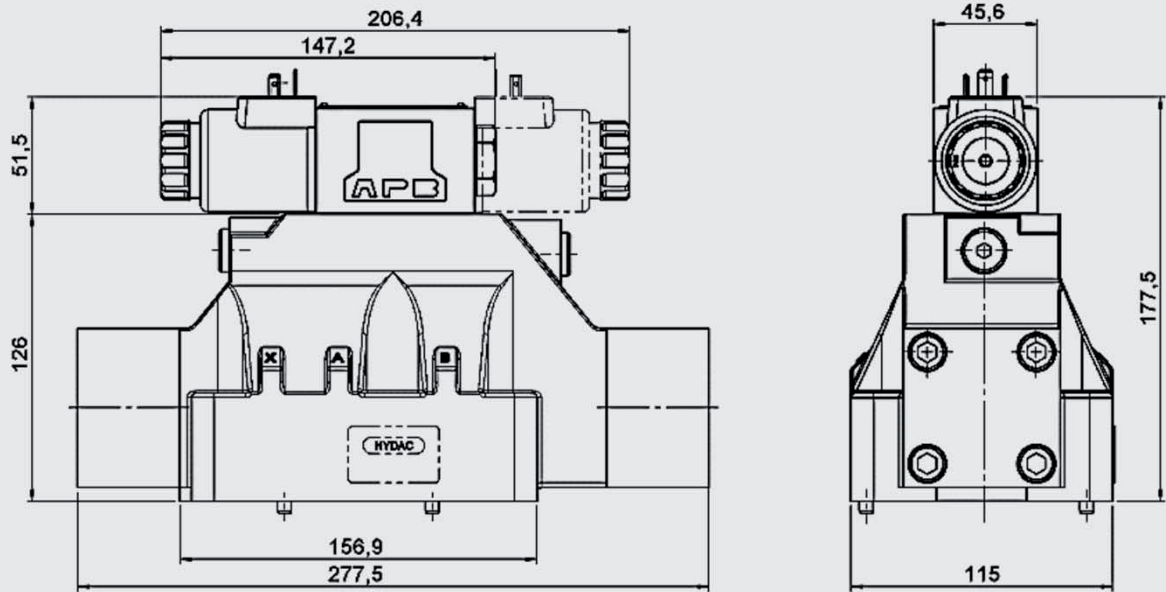

with option D and SZ

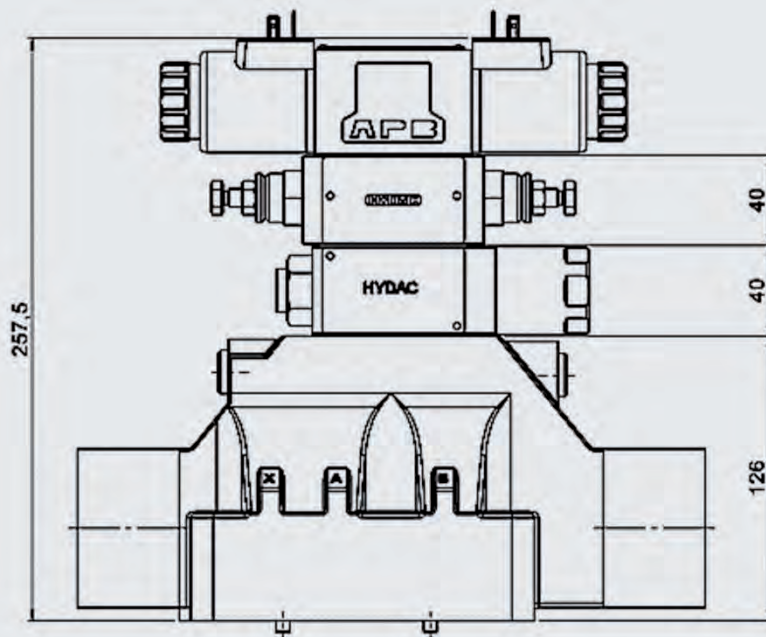

Mounting screws:

(not included in delivery)

6 screws (A10.9) M12x60 ISO4762

Torque: 115 Nm

DIMENSIONS NG32

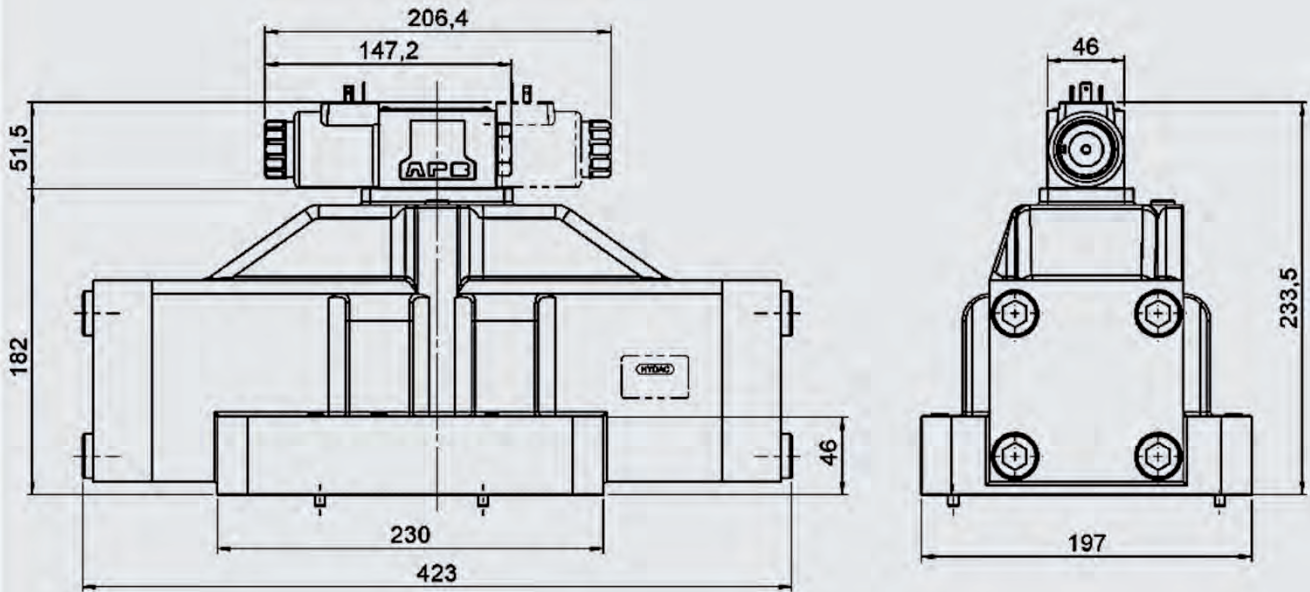



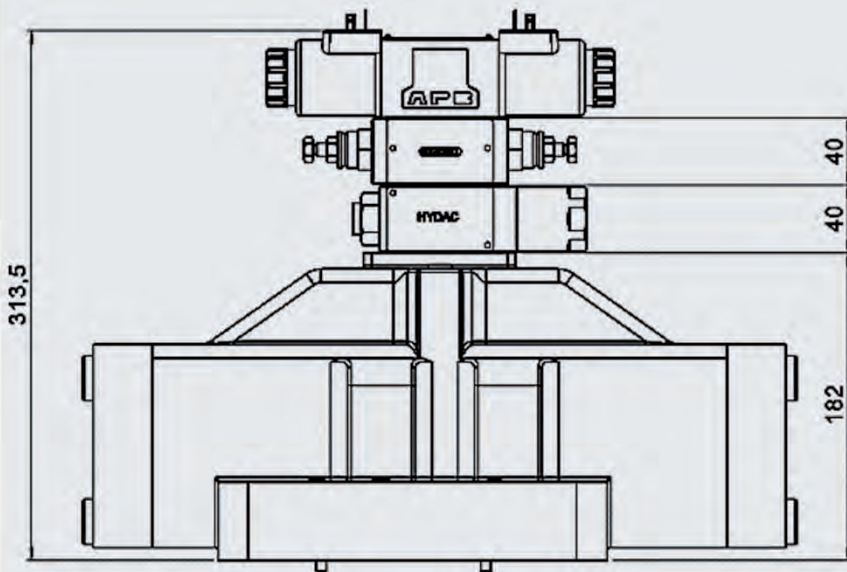

with option D and SZ

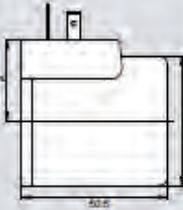
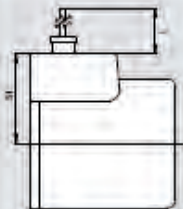

Mounting screws:
(not included in delivery)
6 screws (A10.9) M20x70 ISO4762
Torque: 560 Nm

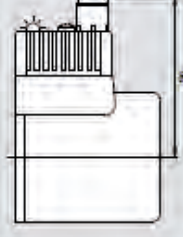
ELECTRICAL CONNECTIONS

G Device connector DIN EN 175301-803 A		<ul style="list-style-type: none"> ● IP65 ● A = 28 mm for DC (DG) ● A = 30.7 mm for AC (AG)
L 2 strands		<ul style="list-style-type: none"> ● IP65 ● Standard strands length L = 457 mm ● Optional with suppressor diode
N Device connector, Deutsch (DT04-2P)		<ul style="list-style-type: none"> ● IP65 / IP67 ● Optional with suppressor diode
O Device connector M12		<ul style="list-style-type: none"> ● IP65 ● With yellow LED as operation indicator ● Pin assignment
U Device connector Junior Timer (axial)		<ul style="list-style-type: none"> ● IP65 ● Optional with suppressor diode

Other models on request

MANUAL OVERRIDES

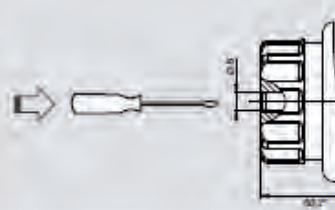
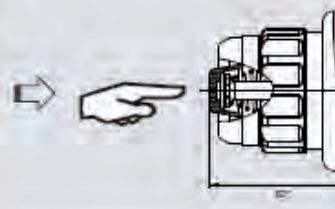
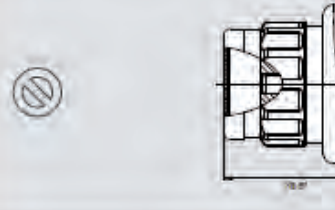
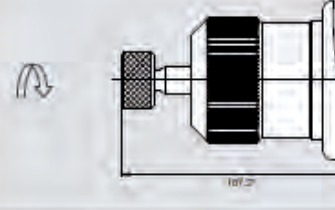
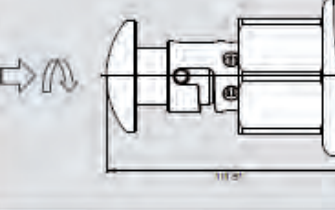
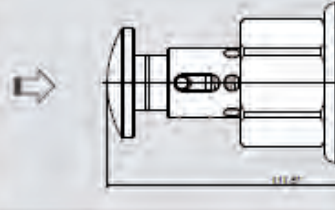
Standard with concealed manual override		Operation with tool
M1 with manual override		Operation without tool with spring return
M2 with covered manual override		Manual override covered, operation only possible after disassembly of cap
M4 with knurled- head screw		Operation by turning the knurled-head screw
M5 with mushroom head (lockable)		Operation by pressing, locking by subsequently turning the mushroom button
M6 with mushroom head (not lockable)		Operation by pressing the mushroom button

* Dimensions up to valve housing

In case of emergency, the valve can also be operated manually. There are different forms of manual override available.

The tank pressure should not exceed 50 bar. If the tank pressure is higher, the force required to operate the manual override increases accordingly.

For valves with two solenoids, simultaneous operation of both manual overrides is not permitted..

ACCESSORIES

	Designation	Part no.
Seals kits (main stage)	4WEH 10: 12,42 x 1,78 90 Sh (5 pcs) 9,25 x 1,78 90 Sh (2 pcs)	FKM: 3524523 NBR: 3524475
	4WEH 16: 22,22 x 2,62 90 Sh (4 pcs) 10,82 x 1,78 90 Sh (2 pcs)	FKM: 3524634 NBR: 3524553
	4WEH 25: 29,82 x 2,62 90 Sh (4 pcs) 20,24 x 2,62 90 Sh (2 pcs)	FKM: 3524660 NBR: 3524659
	4WEH 32: 37,59 x 3,53 90 Sh (4 pcs) 20,24 x 2,62 90 Sh (2 pcs)	FKM: 3524690 NBR: 3524685
Mounting screws	4WEH 10: ISO 4762 M6 x 35 (4 pcs)	3524691
	4WEH 16: ISO 4762 M10 x 60 (4 pcs) ISO 4762 M6 x 60 (2 pcs)	4501973
	4WEH 25: ISO 4762 M12 x 60 (6 pcs)	3524698
	4WEH 32: ISO 4762 M20 x 70 (6 pcs)	3524700
Solenoid coils	COIL 12DG -50-2345 -S	4244169
	COIL 12DN -50-2345 -S	4244170
	COIL 12DO -50-2345 -S	4250874
	COIL 24DG -50-2345 -S	4244171
	COIL 24DN -50-2345 -S	4244172
	COIL 24DO -50-2345 -S	4250885
	COIL 96DG -50-2345 -S	4244173
	COIL 110AG -50-2345 -S	4244174
	COIL 205DG -50-2345 -S	4244275
COIL 230AG -50-2345 -S	4244276	
Seal kit for solenoid coils	Nut open, O-ring	4317299
	Nut with folding cap, O-ring	4317301
	Nut with cap, O-ring	4317302
Connector	Z4 standard 2-pole without PE	394287
	ZW4 incl. rectifier	394293
	Z4L incl. LED	394285
Manual overrides	M4 with knurled-head screw	4429328
	M5 with mushroom manual override (lockable)	4373722
	M6 with mushroom manual override (not lockable)	4373490

Note

The information in this brochure relates to the operating conditions and applications described. For applications not described, please contact the relevant technical department. All technical details are subject to change without notice.

HYDAC Fluidtechnik GmbH
Justus-von-Liebig-Str.
D-66280 Sulzbach/Saar
Tel: 0 68 97 /509-01
Fax: 0 68 97 /509-598
E-Mail: valves@hydac.com

Valves in sandwich plate design Nominal size 6

DESCRIPTION

HYDAC valves in sandwich plate design in nominal size 6 enable modular design of the hydraulic control via stacked valve assembly. We offer them as pressure reducing and pressure relief valves for pressure control and as needle or flow valves with bypass check valve for flow control.

Furthermore, the sandwich plates are available as check valve for direction control, pilot-to-open and non-pilot-to-open, and as pressure compensator to realise the flow control function.

Mounting elements are dependent on the modular design of your hydraulic control and are thus not included in delivery.

FEATURES

- Available with pressure, flow, check and pressure compensator function
- Modular design of the hydraulic control
- Interface to ISO 4401-03-02-0-05 (Cetop 4.2-4-03-350)



Nominal size 6
up to 75 l/min
up to 350 bar

TECHNICAL DATA*

General specifications

Ambient temperature	[°C]	-20 to +60
Installation position		no orientation restrictions
Material		casing: cast iron
		name plate: aluminium
Surface coating		valve casing: phosphate-plated

Hydraulic specifications

Operating pressure	[bar]	350
Operating fluid		Hydraulic oil to DIN 51524 Part 1, 2 and 3
Temp. range of operating fluid	[°C]	-20 to +80
Viscosity	[mm ² /s]	10 to 400
Permitted contamination level of operating fluid		Class 20/18/15 to ISO 4406
Sealing material		NBR, FKM (standard)

*see "Conditions and Instructions for Valves" in brochure 53.000

CONTENTS

Directional valve

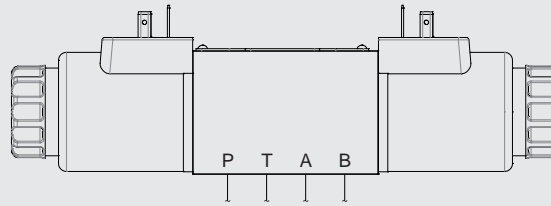

Pressure reducing valves

ZW-DM06...PT

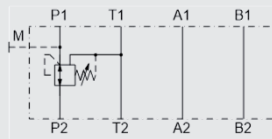

ZW-DM06...PB

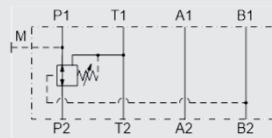

ZW-DM06...PA

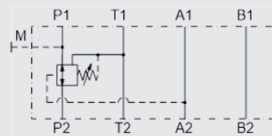

Pressure relief valves

ZW-DM06...AB

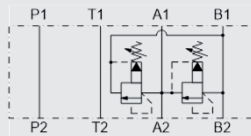

ZW-DM06...AT

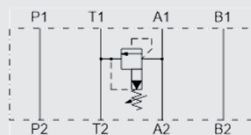

ZW-DM06...BT

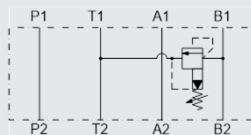

ZW-DM06...ABT

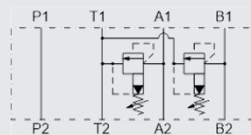

ZW-DM06...PT

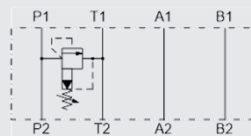

Pressure compensators

ZW-DW06...PAB...V

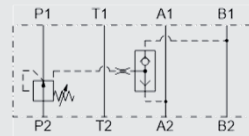

ZW-DW06...PAB

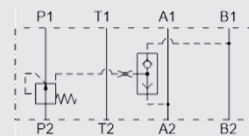

ZW-DW06...PTAB...V

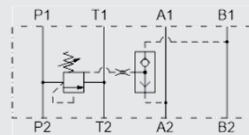

ZW-DW06...PTAB

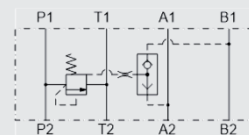

Needle valves

ZW-SDR06...AA

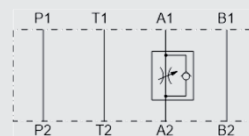

ZW-SDR06...AB

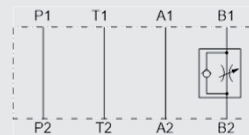

ZW-SDR06...AAB

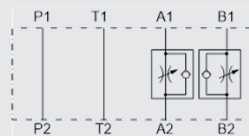

ZW-SDR06...ZAB

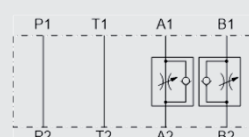

CONTENTS

Directional valve

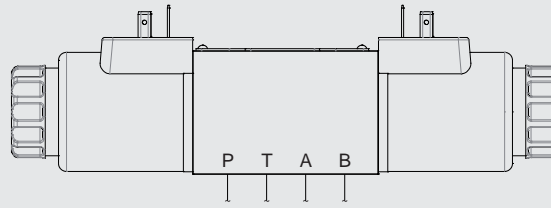

Flow control valves

ZW-2SR06...AA

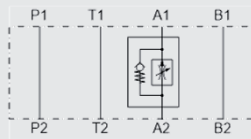

ZW-2SR06...AB

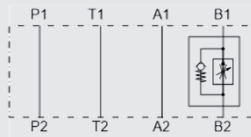

ZW-2SR06...AAB

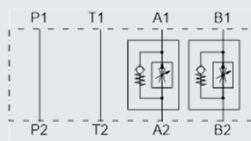

Check valves pilot-to-open

ZW-RP06...AA

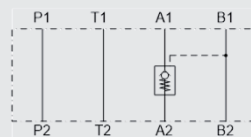

ZW-RP06...AB



ZW-RP06...AAB

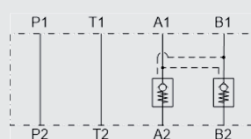

Check valves

ZW-RV06...A

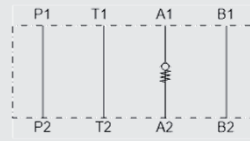

ZW-RV06...B

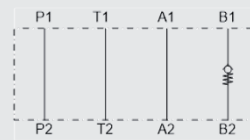

ZW-RV06...P

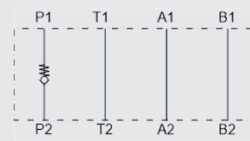

ZW-RV06...T

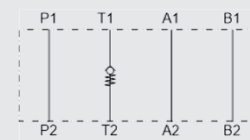

ZW-RV06...AB

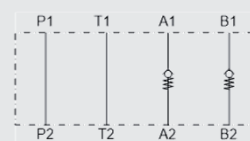

ZW-RV06...PT

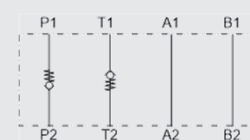

Accessories

PRESSURE REDUCING VALVE IN SANDWICH PLATE DESIGN ZW – DM06



SUPPLEMENTARY TECHNICAL DATA

General specifications

Weight	[kg]	1.4
--------	------	-----

Hydraulic specifications

Tank pressure	[bar]	port T: $p_{\max} = 10$
---------------	-------	-------------------------

Flow rate	[l/min]	50
		75

Leakage	[l/min]	≤ 0.08
---------	---------	-------------

MODEL CODE

ZW-DM 06 - 01 - PA 035 V - N

Type

Pressure reducing valve in sandwich plate design, direct-acting

Nominal size

6

Series

01 = specified by manufacturer

Spool symbol

PA = pressure control in port A
PB = pressure control in port B
PT = pressure control in port T

Pressure ranges

035 = 3 to 35 bar
070 = 10 to 70 bar
140 = 30 to 140 bar
280 = 60 to 280 bar

Adjustment types

V = adjustable using tool

Sealing material

N = NBR
V = FKM (standard)

SPOOL TYPES / SYMBOLS

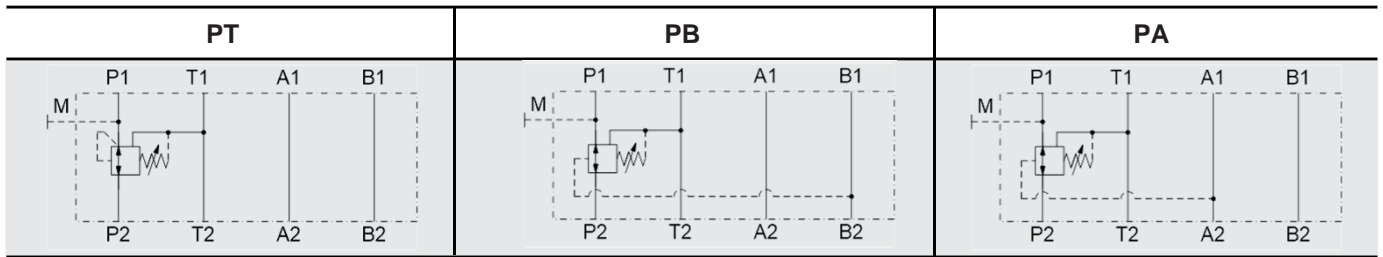

SECTION VIEW

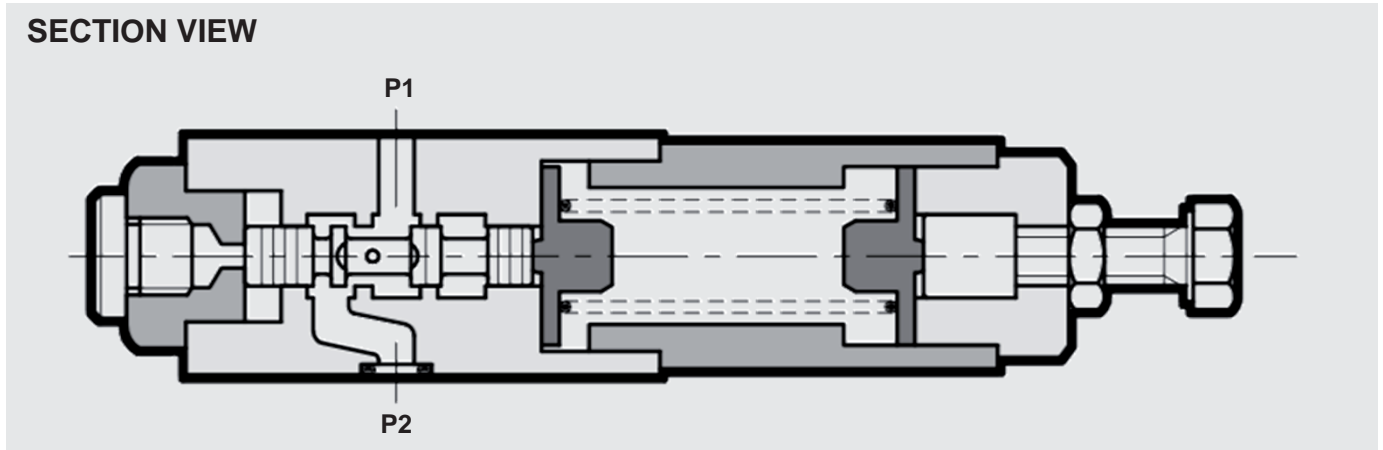

FUNCTION

The direct-acting pressure reducing valve in sandwich plate design in nominal size 6 is used to reduce the inlet pressure at P2 to a smaller outlet pressure P1. The pressure tapping for the reduced pressure is designed differently depending on the symbol:

- reduced pressure in line A → PA
- reduced pressure in line B → PB
- reduced pressure in line P → PT

The outlet pressure P1 can be tapped at measuring port (M).

Hint

In designs PA and PB, the pressure losses of the subsequent components must be considered when selecting the inlet pressure.

PERFORMANCE

measured at $v = 36 \text{ mm}^2/\text{s}$ and $T_{\text{oil}} = 50^\circ\text{C}$

Control

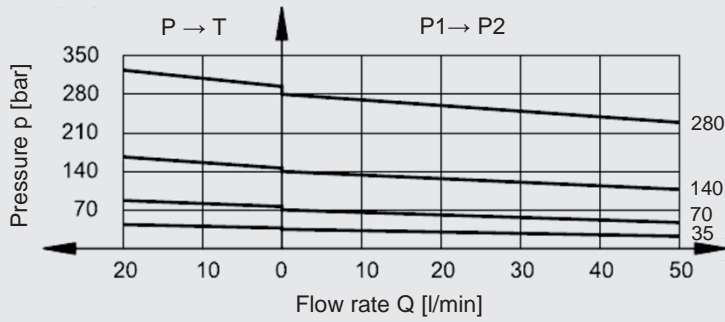

Pressure drop

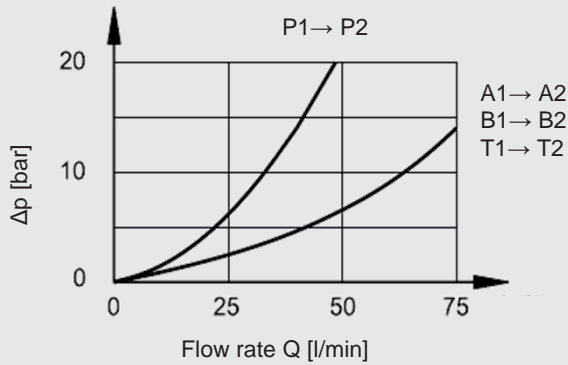

DIMENSIONS

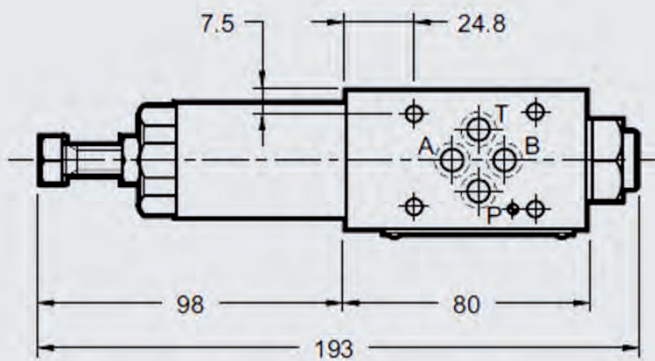

Interface to ISO 4401-03-02-0-05 (Cetop 4.2-4-03-350)

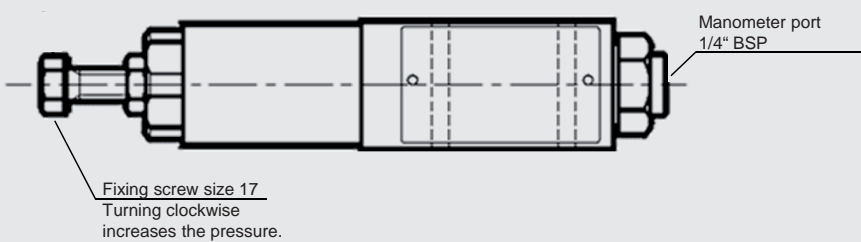
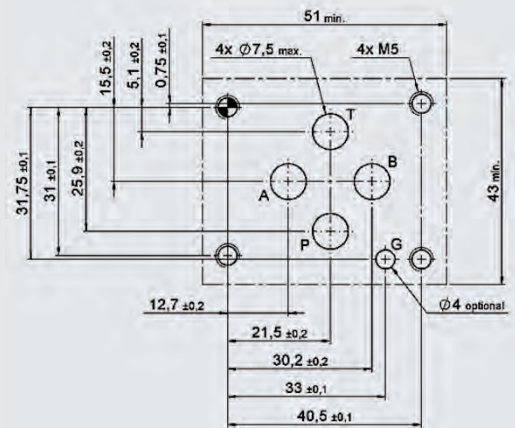

PRESSURE RELIEF VALVE IN SANDWICH PLATE DESIGN ZW – DB06



SUPPLEMENTARY TECHNICAL DATA

General specifications

Weight	[kg]	1.4
		2.1 (symbol ABT)

Hydraulic specifications

Flow rate	[l/min]	75
-----------	---------	----

MODEL CODE

ZW-DB 06 - 01 - AB 70 V - N

Type

Pressure relief valve in sandwich plate design, pilot-operated

Nominal size

6

Series

01 = specified by manufacturer

Spool symbol

AB = pressure relief in port B, meter-out in port A
 AT = pressure relief in port A, meter-out in port T
 BT = pressure relief in port B, meter-out in port T
 PT = pressure relief in port P, meter-out in port T
 ABT = pressure relief in port A and B, meter-out in port T

Pressure ranges

070 = up to 70 bar
 140 = up to 140 bar
 210 = up to 210 bar
 350 = up to 350 bar

Adjustment types

V = adjustable using tool

Sealing material

N = NBR
 V = FKM (standard)

SPOOL TYPES / SYMBOLS

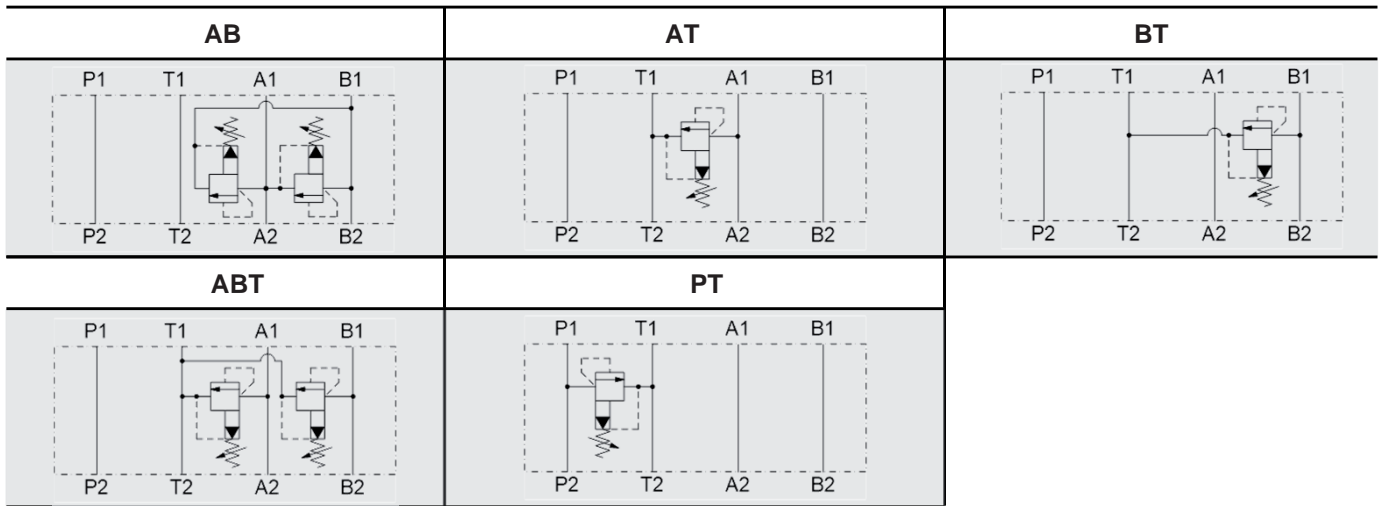

SECTION VIEW

Example PT

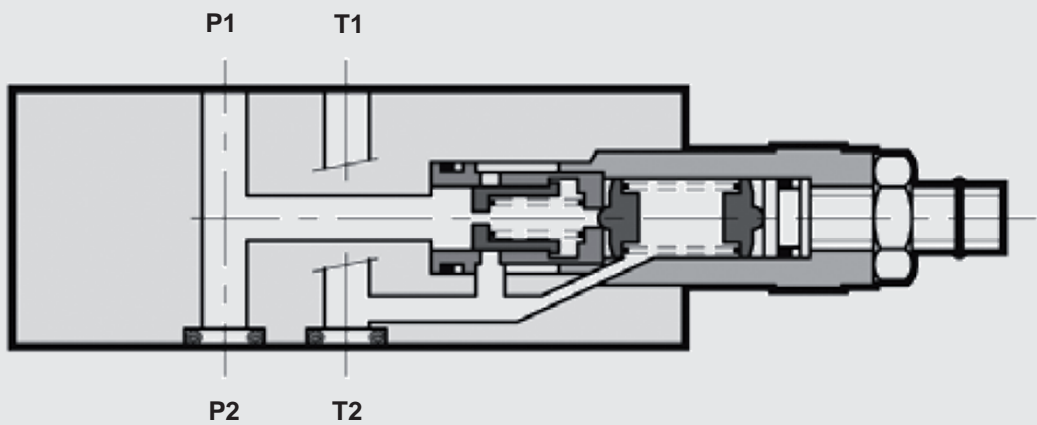

FUNCTION

The pressure relief valve is a pilot-operated spool valve in sandwich plate design in nominal size 6, which limits the pressure in the system.

If the pressure at port P exceeds the pressure setting, the pilot stage opens, so a small flow flows to the tank via pilot stage. Because of the resulting pressure difference, the main piston moves towards the return spring and allows flow from port P to T.

PERFORMANCE

measured at $v = 36 \text{ mm}^2/\text{s}$ and $T_{\text{oil}} = 50^\circ\text{C}$

Control

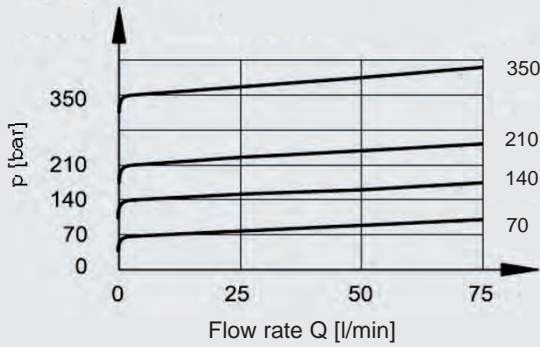

Pressure drop

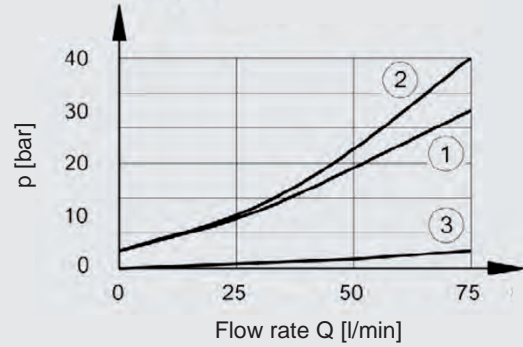

- 1) Controlled port, symbol PT, AT, BT
- 2) Controlled port, symbol AB, ABT
- 3) Free port

DIMENSIONS

Symbol AT

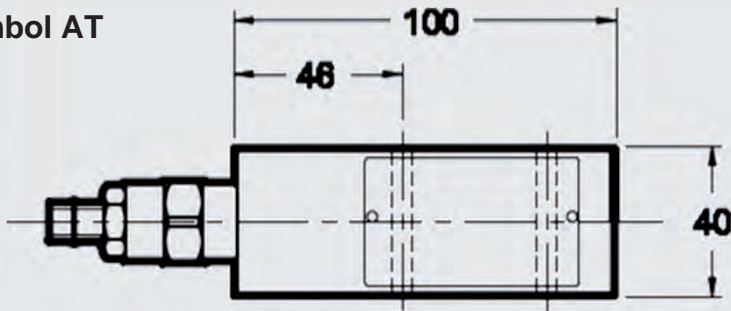

Interface to ISO 4401-03-02-0-05

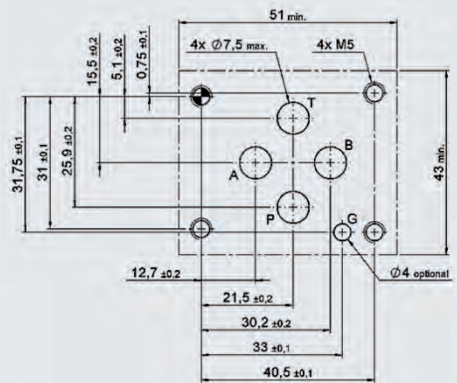

Symbol PT, BT

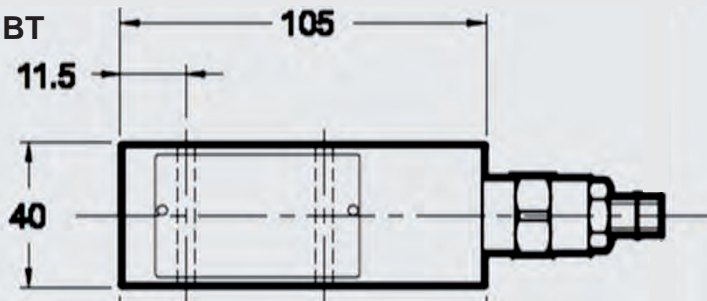

Symbol AB, ABT

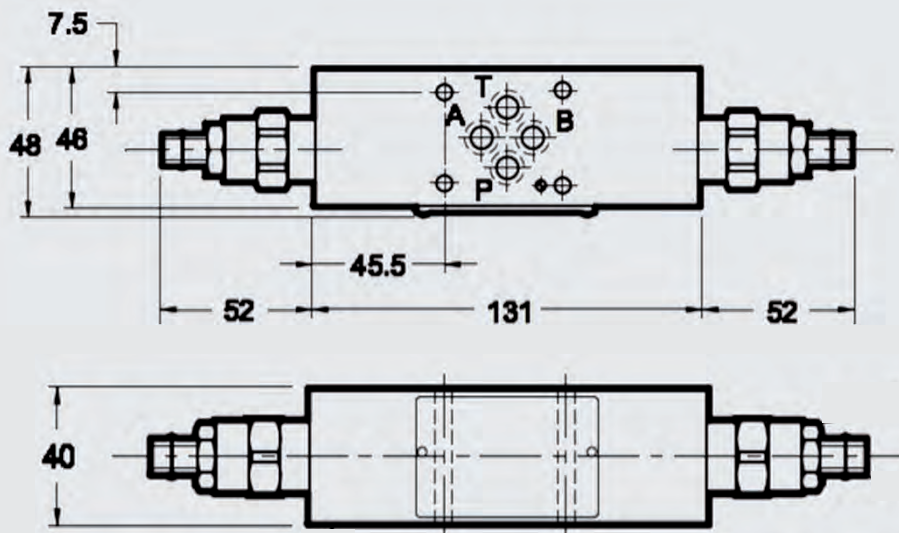

PRESSURE COMPENSATOR IN SANDWICH PLATE DESIGN ZW – DW06



SUPPLEMENTARY TECHNICAL DATA

General specifications

Weight [kg] 1.5

Hydraulic specifications

Flow rate [l/min] 40

MODEL CODE

ZW-DW 06 - 01 - PAB 33 V - N

Type

Pressure compensator in sandwich plate design

Nominal size

6

Series

01 = specified by manufacturer

Spool symbol

PAB = 2-way pressure compensator
PTAB = 3-way pressure compensator

Setting ranges

4 = 4 bar
8 = 8 bar
33 = 7 to 33 bar

Adjustment types

Not specified = non-adjustable
V = adjustable using tool (only with setting range 33 bar)

Sealing material

N = NBR
V = FKM (standard)

SPOOL TYPES / SYMBOLS

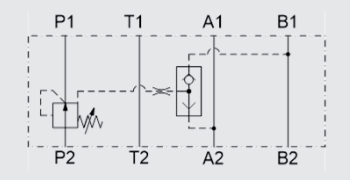
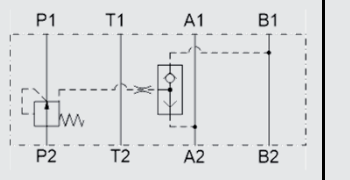
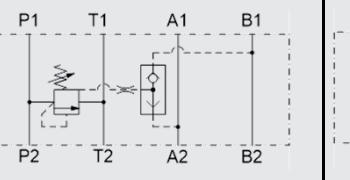
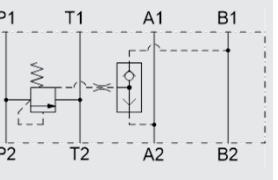
PAB...V (adjustable)	PAB	PTAB...V (adjustable)	PTAB
			

SECTION VIEW

Example PAB

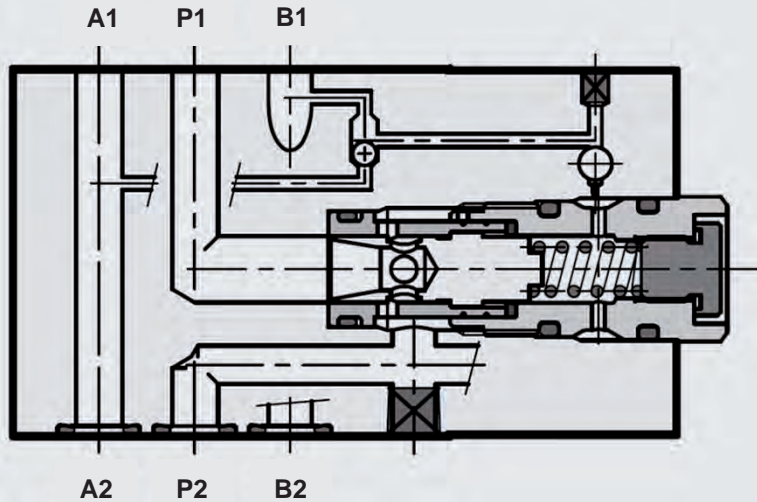

FUNCTION

The pressure compensator in sandwich plate design in nominal size 6 keeps the pressure loss constant between inlet port P and – depending on the remote control of the integrated shuttle valve – the inlet to either consumer port A or B. In combination with a needle valve or proportional directional valve results in a constant flow to the consumer at port A or B. The control pressure of the pressure compensator can be specified between 7 and 33 bar via an internal hexagon adjustment screw. Non-adjustable pressure compensators are available with a control pressure of 4 or 8 bar.

The valve is available as a 2- or 3-way pressure compensator.

For the 3-way pressure compensator, an excess flow flows to tank port T.

Application example for a meter-in flow control at cylinder port A or B with a proportional directional valve:

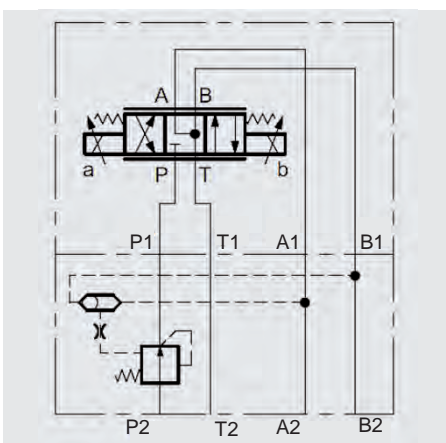

PERFORMANCE

measured at $v = 36 \text{ mm}^2/\text{s}$ and $T_{\text{oil}} = 50^\circ\text{C}$

2-way pressure compensator

Flow pressure $Q = f(p)$

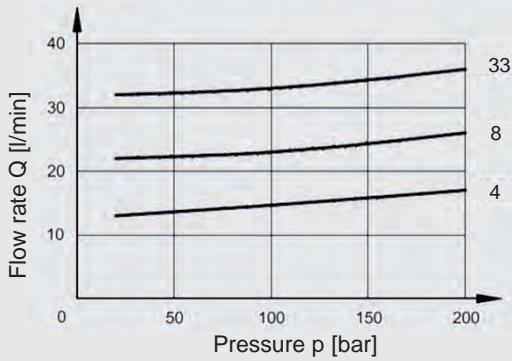

Pressure drop $\Delta p = f(Q)$

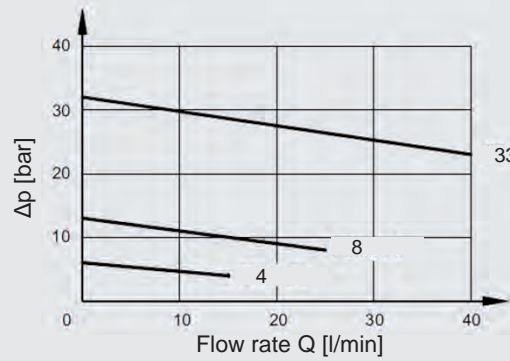

3-way pressure compensator

Flow pressure $Q = f(p)$

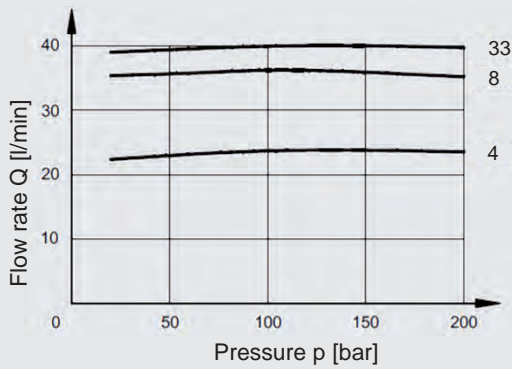

Pressure drop $\Delta p = f(Q)$

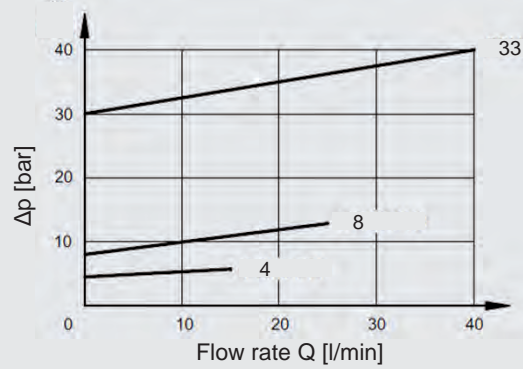

DIMENSIONS

Interface to ISO 4401-03-02-0-05
(Cetop 4.2-4-03-350)

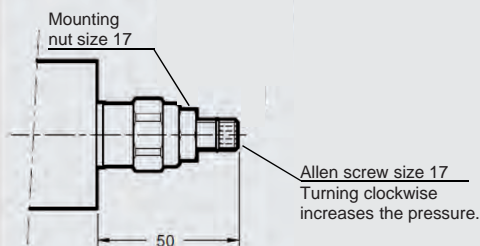
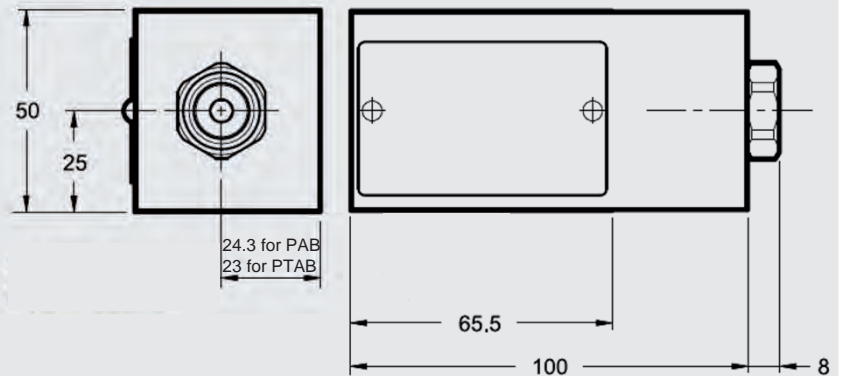
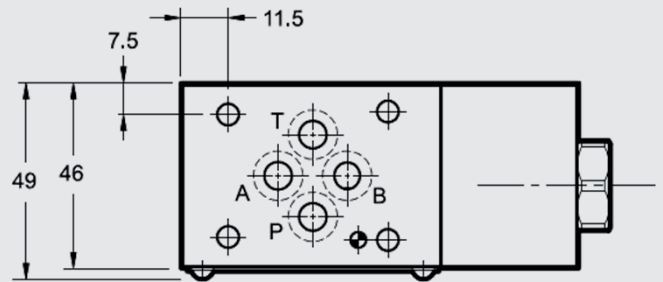
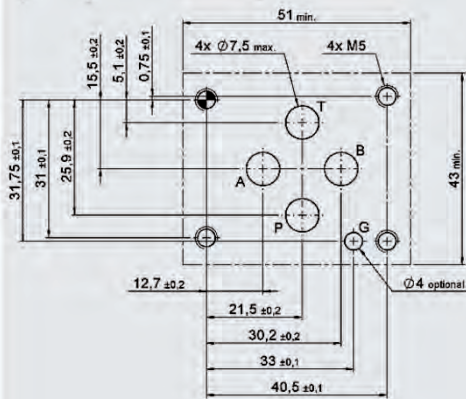

NEEDLE VALVE IN SANDWICH PLATE DESIGN ZW – SDR06



SUPPLEMENTARY TECHNICAL DATA

General specifications

Weight [kg] 1.3

Hydraulic specifications

Cracking pressure [bar] 0.5
check valve

Flow rate [l/min] 50 in controlled port
75 in free port

MODEL CODE

ZW-SDR 06 - 01 - AAB - N

Type

Needle valve in sandwich plate design

Nominal size

6

Series

01 = specified by manufacturer

Spool symbol

AA = meter-out in port A

AB = meter-out in port B

AAB = meter-out in port A and B

ZAB = meter-in in port A and B

Sealing material

N = NBR

V = FKM (standard)

SPOOL TYPES / SYMBOLS

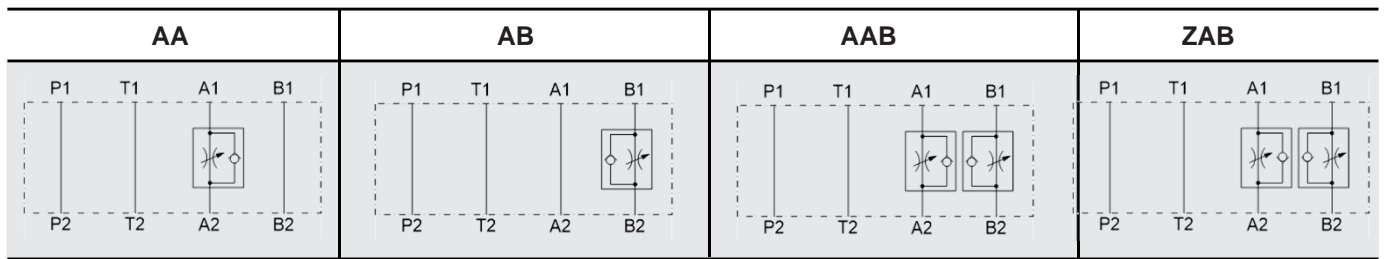

SECTION VIEW

Example ZAB

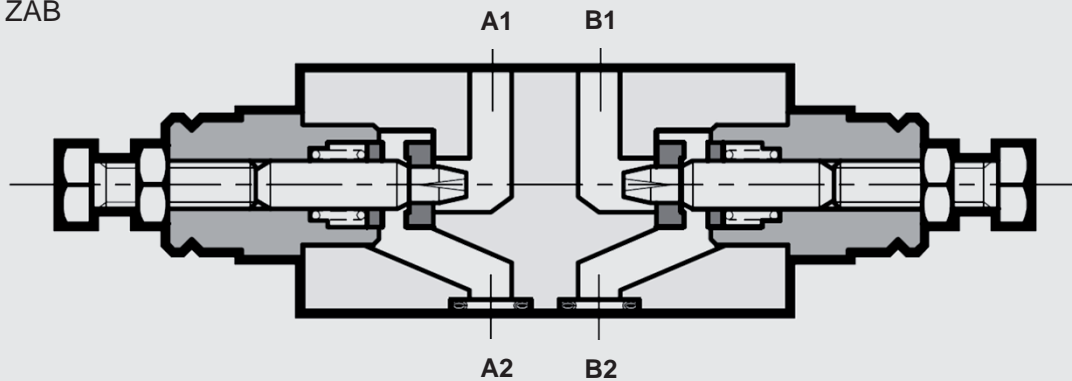

FUNCTION

The needle valve in sandwich plate design in nominal size 6 is used to control a flow in flow direction.

In the reverse direction there is free flow through the valve if the cracking pressure is exceeded. The valve opens when the inlet pressure at the check valve is higher than the outlet pressure including the pressure spring force.

The throttling of the flow rate depends on the version:

- flow from consumer to directional valve in port A → AA
- flow from consumer to directional valve in port B → AB
- flow from consumer to directional valve in port A and B → AAB
- flow from directional valve to consumer in port A and B → ZAB

PERFORMANCE

measured at $v = 36 \text{ mm}^2/\text{s}$ and $T_{\text{oil}} = 50^\circ\text{C}$

Control

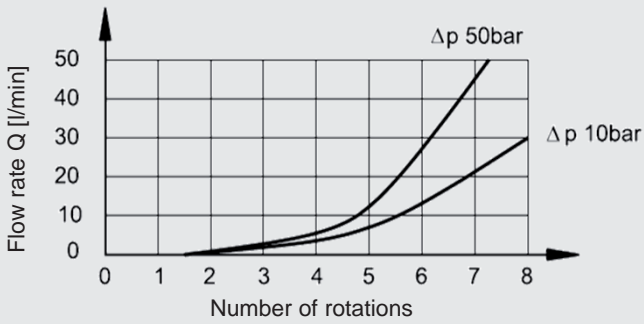

Pressure drop

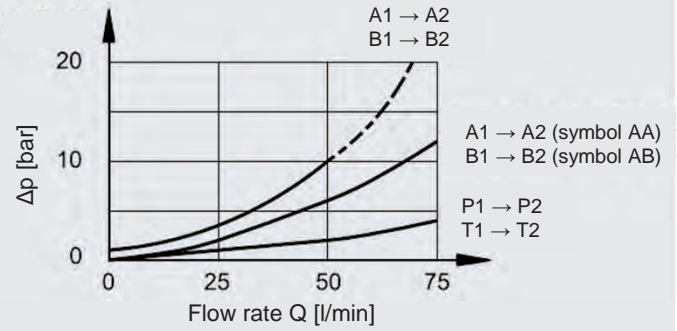

DIMENSIONS

Interface to ISO 4401-03-02-0-05
(Cetop 4.2-4-03-350)

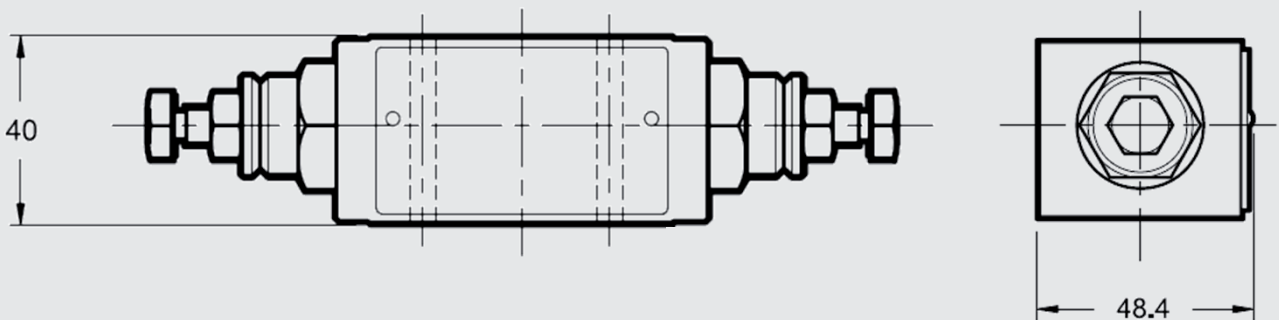
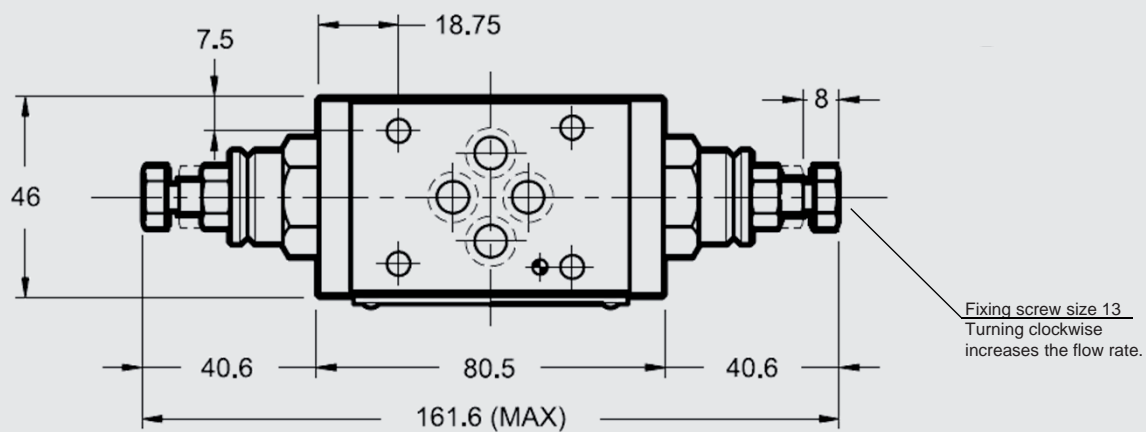
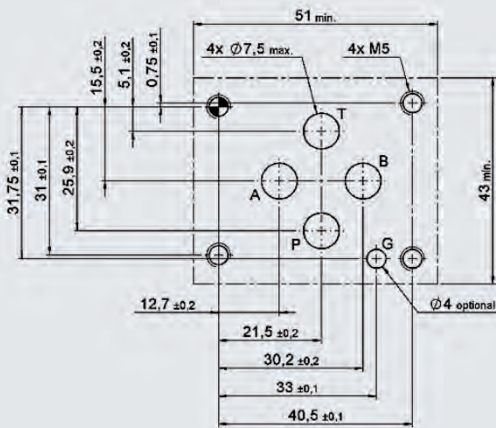

FLOW CONTROL VALVE IN SANDWICH PLATE DESIGN ZW – 2SR06



SUPPLEMENTARY TECHNICAL DATA

General specifications

Weight	[kg]	3 (symbol AA, AB) 4.1 (symbol AAB)
--------	------	---------------------------------------

Hydraulic specifications

Operating pressure	[bar]	250
Cracking pressure check valve	[bar]	0.5
Flow rate	[l/min]	controlled port: 1, 4, 10, 16, 22, 30 Free port: 65 (40 free flow in opposite direction)

MODEL CODE

ZW-2SR 06 - 01 - AA - 01 - N

Type

Flow control valve in sandwich plate design

Nominal size

6

Series

01 = specified by manufacturer

Spool symbol

AA = meter-out in port A

AB = meter-out in port B

AAB = meter-out in port A and B

Adjustment ranges, flow rate

01 = 1 bar

04 = 4 bar

10 = 10 bar

16 = 16 bar

22 = 22 bar

30 = 30 bar

Sealing material

N = NBR

V = FKM (standard)

SPOOL TYPES / SYMBOLS

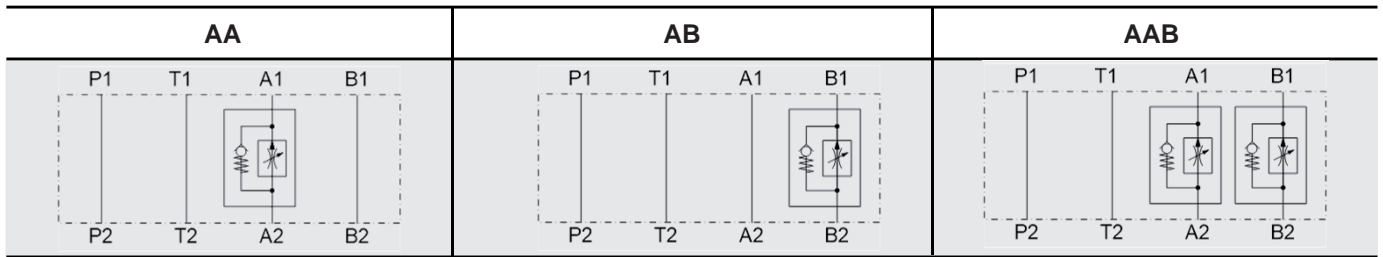

SECTION VIEW

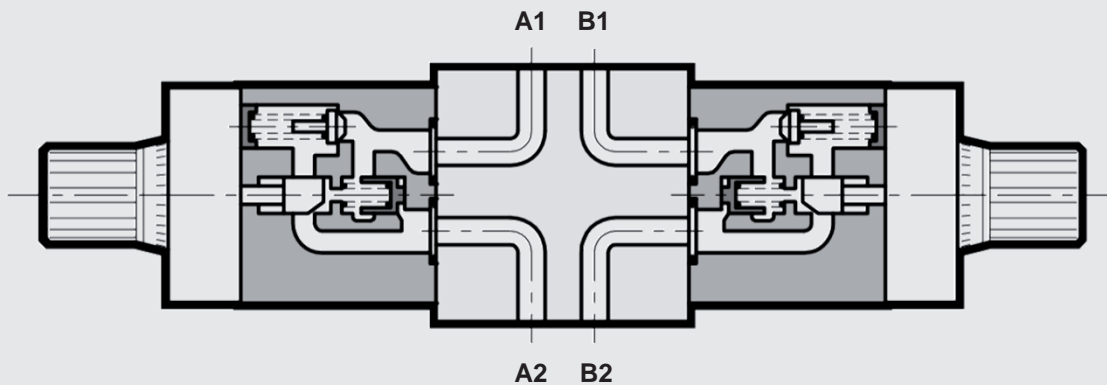

FUNCTION

The flow control valve in sandwich plate design in nominal size 6 is used to control a flow in flow direction. The flow rate is kept constant independent of the pressure loss at the consumer. In the reverse direction there is free flow through the valve if the cracking pressure is exceeded. The valve opens when the inlet pressure at the check valve is higher than the outlet pressure including the pressure spring force.

The control of the flow rate depends on the version:

- flow from consumer to directional valve in port A → AA
- flow from consumer to directional valve in port B → AB
- flow from consumer to directional valve in port A and B → AAB

PERFORMANCE

measured at $v = 36 \text{ mm}^2/\text{s}$ and $T_{\text{oil}} = 50^\circ\text{C}$

Control

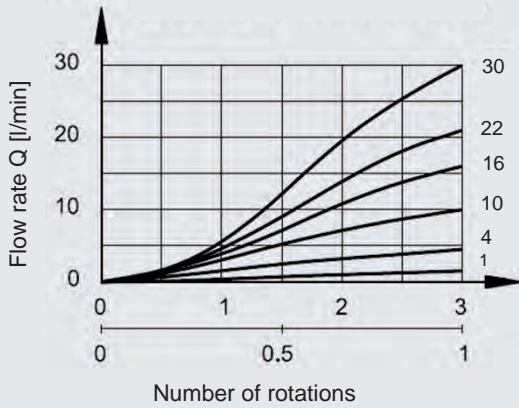

Pressure drop

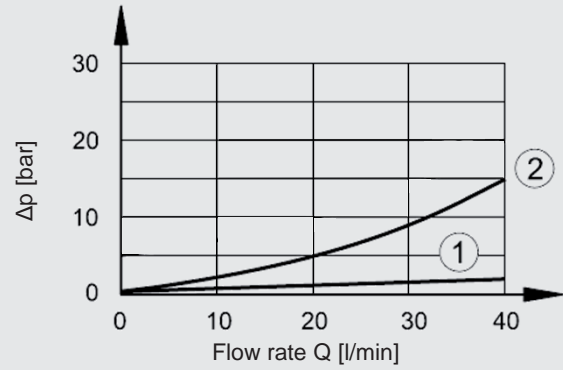

- 1) Free port
- 2) Check valve

DIMENSIONS

Interface to ISO 4401-03-02-0-05
(Cetop 4.2-4-03-350)

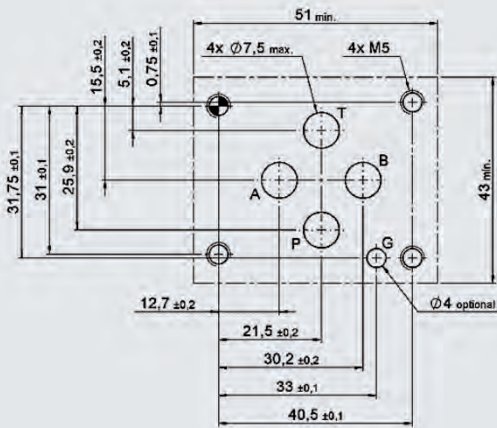

AAB

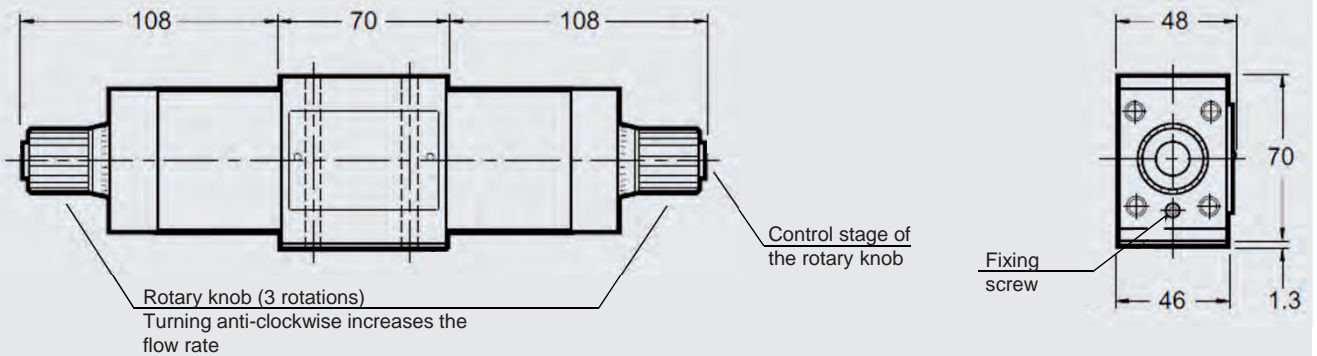

AA

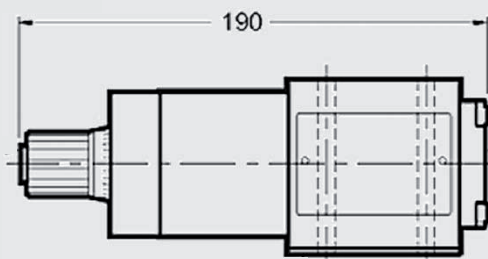

AB

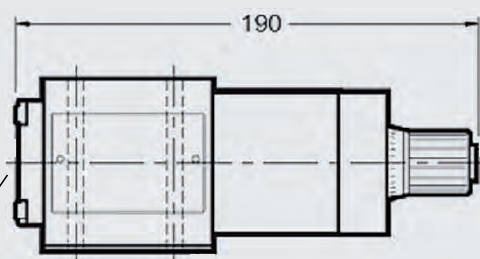

CHECK VALVE, PILOT-TO-OPEN IN SANDWICH PLATE DESIGN ZW – RP06



SUPPLEMENTARY TECHNICAL DATA

General specifications

Weight [kg] 1.3

Hydraulic specifications

Cracking pressure [bar] 3
check valve

Flow rate [l/min] 50 in controlled port
75 in free port

Pilot ratio 3.4 : 1

MODEL CODE

ZW-RP 06 - 01 - AA - N

Type

Check valve, pilot-to-open in sandwich plate design

Nominal size

6

Series

01 = specified by manufacturer

Spool symbol

AA = meter-out in port A

AB = meter-out in port B

AAB = meter-out in port A and B

Sealing material

N = NBR

V = FKM (standard)

SPOOL TYPES / SYMBOLS

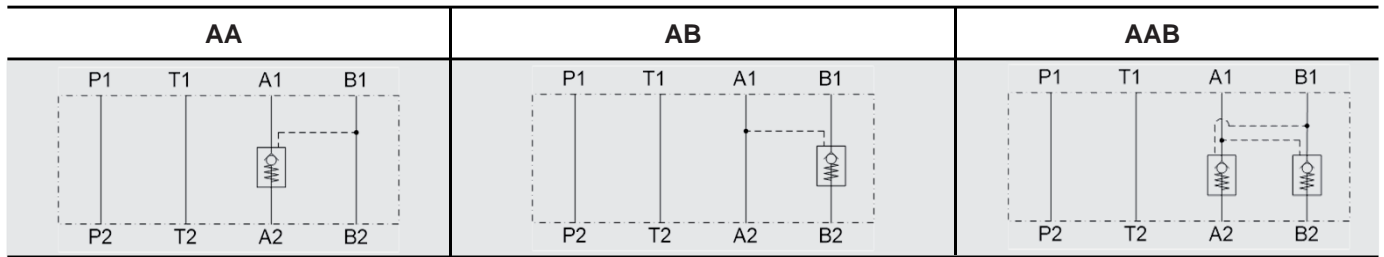

SECTION VIEW

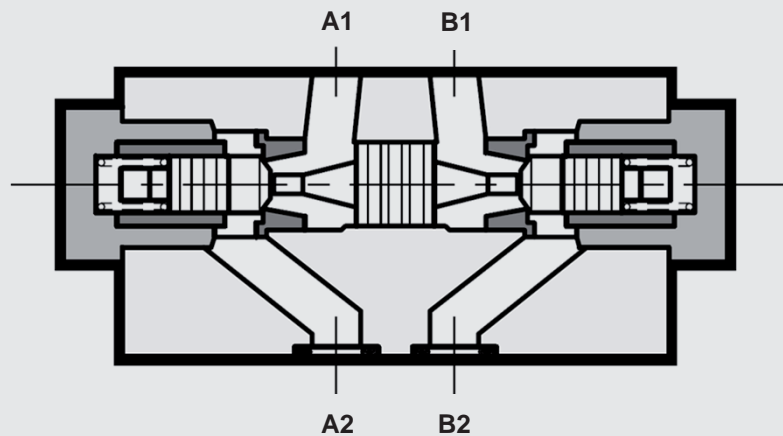

FUNCTION

The check valve, pilot-to-open in sandwich plate design in nominal size 6 is a direct-acting, spring-loaded poppet valve. It releases flow from the directional valve to the consumer and blocks flow from the consumer to the directional valve. Thereby the valve poppet is pressed into the seat and blocks the flow. If sufficiently high control pressure is built up in the relevant control port, the valve is unlocked and flow flows from the consumer to the directional valve. The required control pressure is based on the pressure difference between the ports to be unblocked.

Hint

A pressure in the port of the directional valve influences the required control pressure.

PERFORMANCE

measured at $v = 36 \text{ mm}^2/\text{s}$ and $T_{\text{oil}} = 50^\circ\text{C}$

Pressure drop

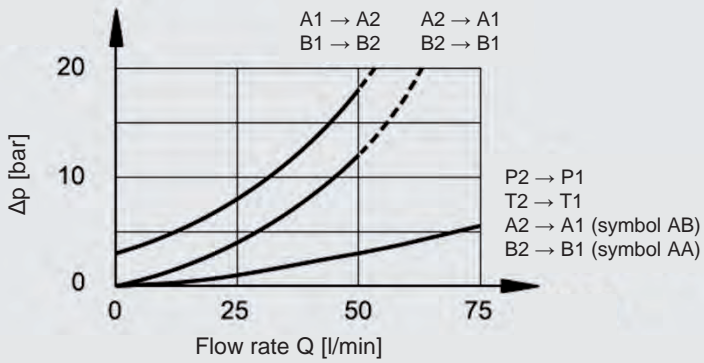

Use the following formula to calculate the min. required pilot pressure in port B:

$$p_{\text{control}} = \frac{p_{A2} - p_{A1}}{\phi} + p_{A1}$$

Use the following formula to calculate the min. required pilot pressure in port A:

$$p_{\text{control}} = \frac{p_{B2} - p_{B1}}{\phi} + p_{B1}$$

DIMENSIONS

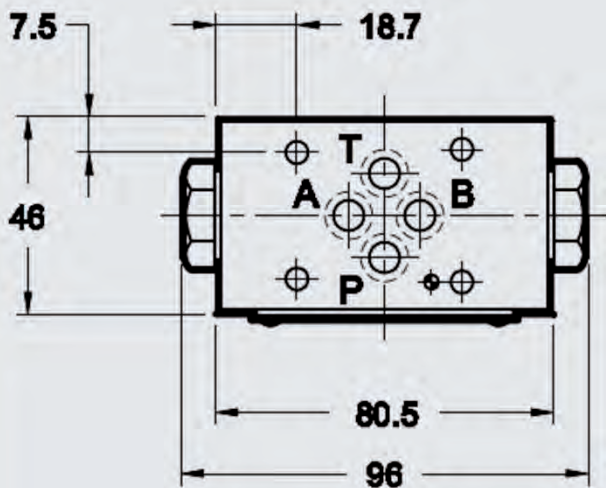

Interface to ISO 4401-03-02-0-05 (Cetop 4.2-4-03-350)

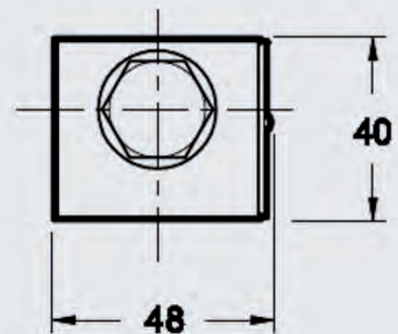
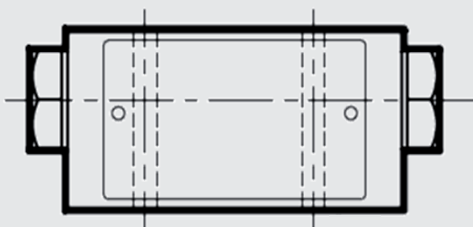
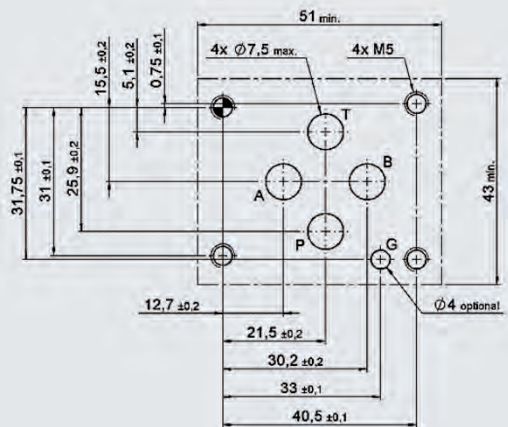

CHECK VALVE IN SANDWICH PLATE DESIGN ZW – RV06



SUPPLEMENTARY TECHNICAL DATA

General specifications

Weight [kg] 1

Hydraulic specifications

Cracking pressure [bar] 0.5
check valve 3
5

Flow rate [l/min] 50 in controlled port
75 in free port

MODEL CODE

ZW-RV 06 - 01 - A 0,5 - N

Type

Check valve in sandwich plate design

Nominal size

6

Series

01 = specified by manufacturer

Spool symbol

A = check valve in port A
B = check valve in port B
P = check valve in port P
T = check valve in port T
AB = check valve in port AB
PT = check valve in port PT

Cracking pressure

0.5 = 0.5 bar
Other cracking pressures on request

Sealing material

N = NBR
V = FKM (standard)

SPOOL TYPES / SYMBOLS

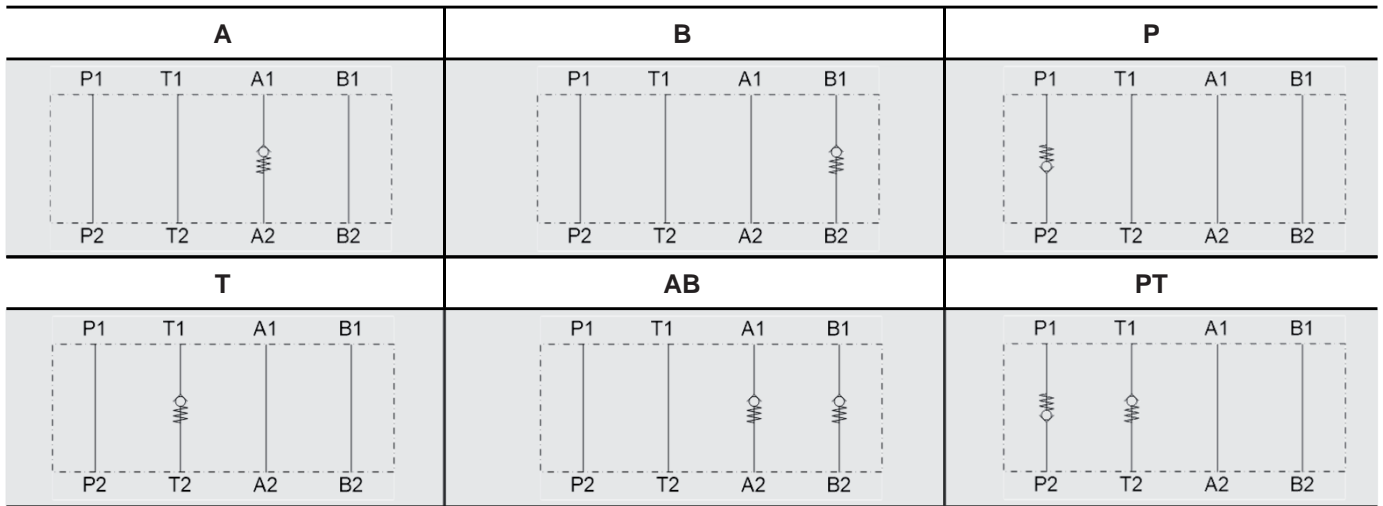

SECTION VIEW

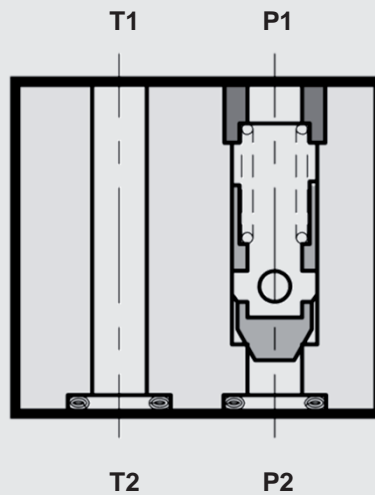

FUNCTION

The check valve in sandwich plate design in nominal size 6 is a direct-acting, spring-loaded poppet valve. The valve releases a flow in one direction after exceeding the spring force and blocks the flow in the opposite direction. Thereby the valve poppet is pressed into the seat and blocks the flow.

- Flow blocked in port A from consumer to directional valve → A
- Flow blocked in port B from consumer to directional valve → B
- Meter-out blocked to pressure supply → P
- Preload of meter-out to tank → T
- Flow blocked in port A and B from consumer to directional valve → AB
- Meter-out blocked to pressure supply and preload of meter-out to tank → PT

Hint

Spring-side pressures at the check element are added to its cracking pressure.

PERFORMANCE

measured at $v = 36 \text{ mm}^2/\text{s}$ and $T_{\text{oil}} = 50^\circ\text{C}$

Pressure drop

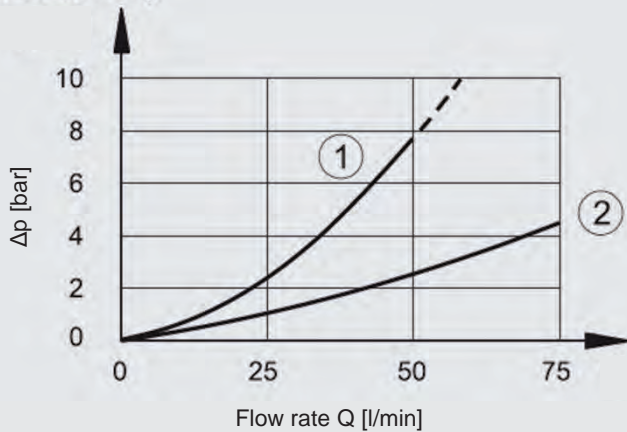

- 1) Controlled port (includes valve element)
- 2) Free port

Hint

The cracking pressure of the valve is added to the values of the performance curve 1).

DIMENSIONS

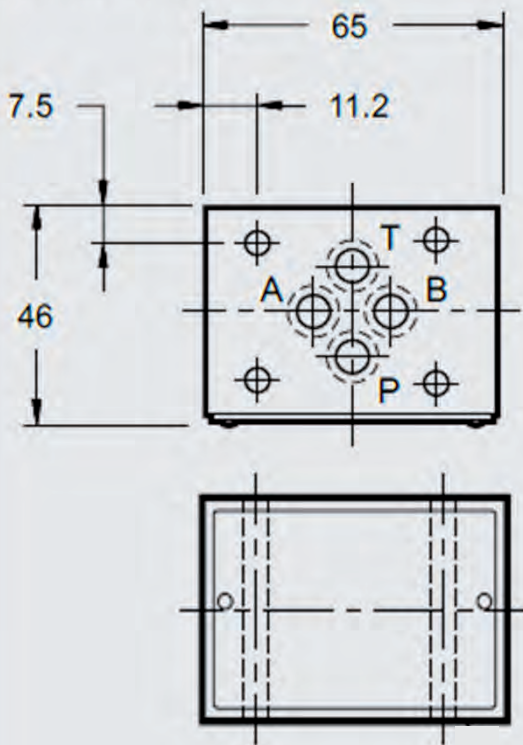

Interface to ISO 4401-03-02-05 (Cetop 4.2-4-03-350)

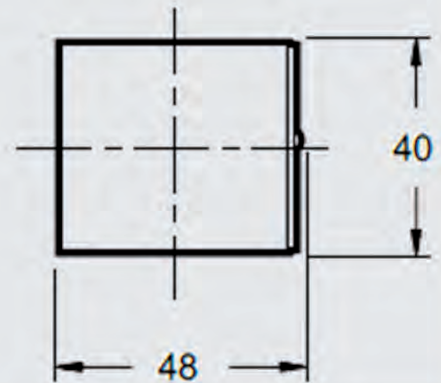
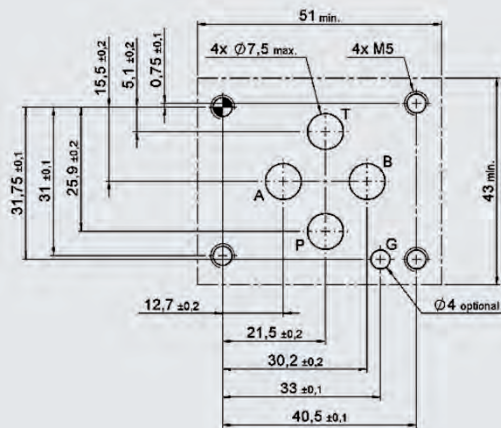

Note

The information in this brochure relates to the operating conditions and applications described. For applications not described, please contact the relevant technical department. Subject to technical modifications.

ACCESSORIES

	Designation	Part no.
Seal kits (4-part set)	9.25 x 1.78 80 Sh NBR	3492432
	9.25 x 1.78 80 Sh FKM	3120269

HYDAC Fluidtechnik GmbH
Justus-von-Liebig-Str.
66280 Sulzbach/Saar, Germany
Tel: 0 68 97 /509-01
Fax: 0 68 97 /509-598
E-mail: valves@hydac.com

Valves in sandwich plate design Nominal size 10

DESCRIPTION

HYDAC valves in sandwich plate design in nominal size 10 enable modular design of the hydraulic control via stacked valve assembly. We offer them as pressure reducing and pressure relief valves for pressure control and as needle or flow valves with bypass check valve for flow control.

Furthermore, the sandwich plates are available as check valve for direction control, pilot-to-open and non-pilot-to-open, and as pressure compensator to realise the flow control function.

Mounting elements are dependent on the modular design of your hydraulic control and are thus not included in delivery.

FEATURES

- Available with pressure, flow, check and pressure compensator function
- Modular design of the hydraulic control
- Interface to ISO 4401-05-04-0-05 (Cetop 4.2-4-05-350)



Nominal size 10
up to 120 l/min²
up to 350 bar²

TECHNICAL DATA¹

General specifications		
Ambient temperature	[°C]	-20 to +60
Mounting position		no orientation restrictions
Material		Casing: cast iron Name plate: aluminium
Surface coating		Valve housing: phosphate-plated
Hydraulic specifications		
Operating pressure	[bar]	350 ²
Operating fluid		Hydraulic oil to DIN 51524 Part 1, 2 and 3
Temp. range of operating fluid	[°C]	-20 to +70
Viscosity	[mm ² /s]	10 to 400
Permitted contamination level of operating fluid		Class 20/18/15 to ISO 4406
Sealing material		NBR, FKM (standard)

¹ see "Conditions and Instructions for Valves" in brochure 53.000

² in consideration of the charts "Supplementary technical data"

CONTENTS

Directional valve

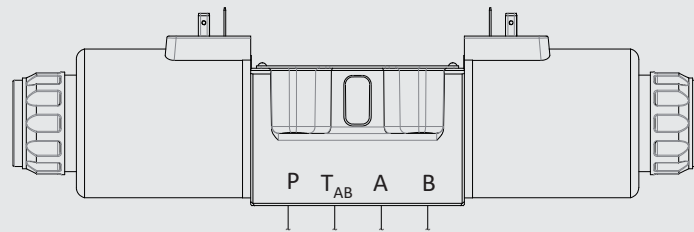

Pressure reducing valves

ZW-DM10...PT

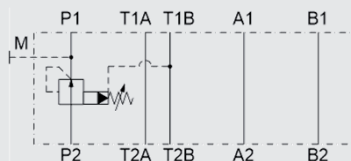

ZW-DM10...PB

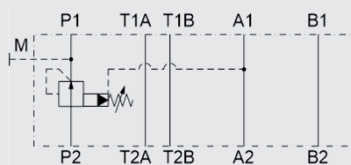

ZW-DM10...PA

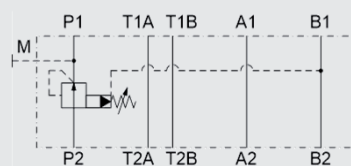

Pressure relief valves

ZW-DB10...AB

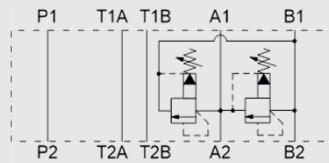

ZW-DB10...AT

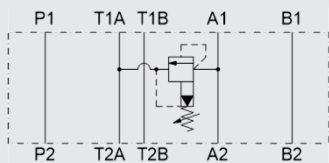

ZW-DB10...BT

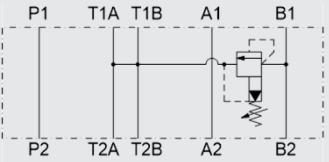

ZW-DB10...ABT

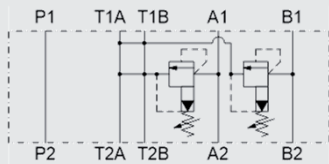

ZW-DB10...PT

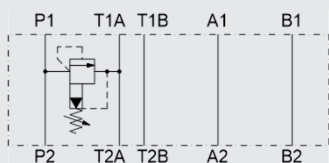

Pressure compensators

ZW-DW10...PAB

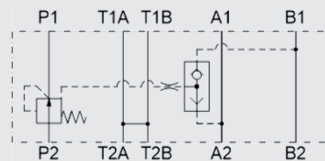

Needle valves

ZW-SDR10...AAB

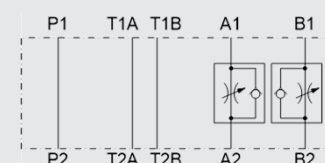

ZW-SDR10...ZAB

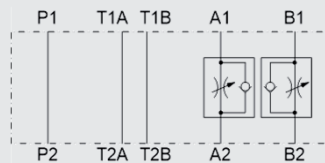

CONTENTS

Directional valve

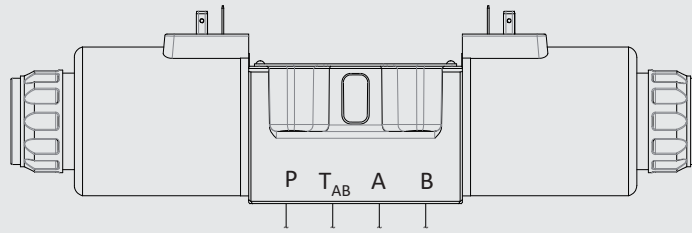

Check valves pilot-to-open

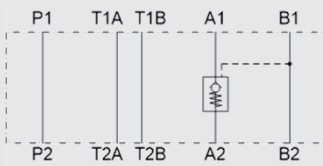

ZW-RP10...AA



ZW-RP10...AB

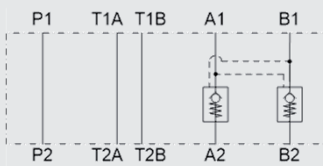

ZW-RP10...AAB

Check valves



ZW-RV10...A

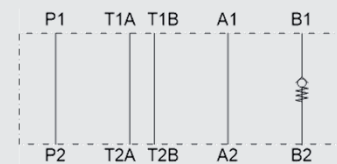

ZW-RV10...B



ZW-RV10...P

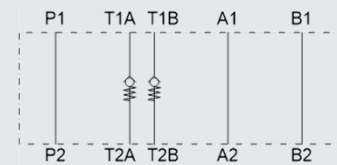

ZW-RV10...T

Accessories

PRESSURE REDUCING VALVE IN SANDWICH PLATE DESIGN ZW – DM10



SUPPLEMENTARY TECHNICAL DATA

General specifications

Weight [kg] 2.7

Hydraulic specifications

Pressure symbol PA, PB [bar] 210

Flow rate [l/min] 80 controlled line P
100 free lines

Leakage [l/min] < 0.7

MODEL CODE

ZW-DM 10 - 01 - PA - 070 V - N

Type

Pressure reducing valve in sandwich plate design, pilot-operated

Nominal size

10

Series

01 = specified by manufacturer

Spool symbol

PA = pressure control in port A
PB = pressure control in port B
PT = pressure control in port T

Pressure ranges

070 = 5 to 70 bar
140 = 8 to 140 bar
210 = 10 to 210 bar
320 = 15 to 320 bar (symbol PT only)

Adjustment types

V = adjustable using tool

Sealing material

N = NBR
V = FKM (standard)

SPOOL TYPES / SYMBOLS

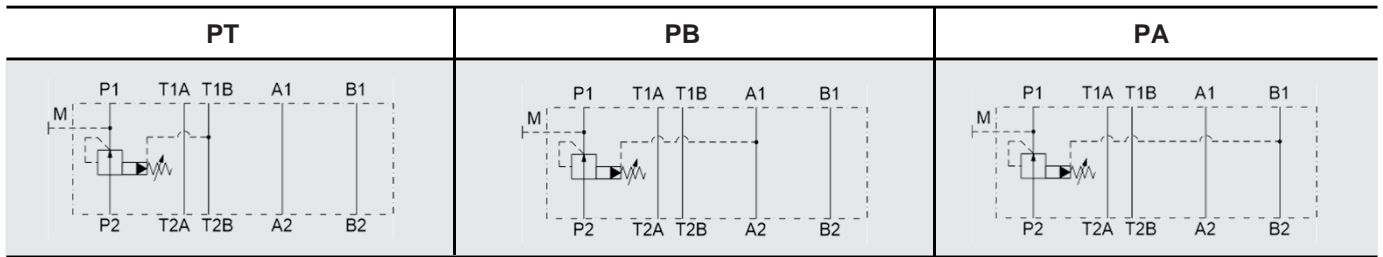

SECTION VIEW

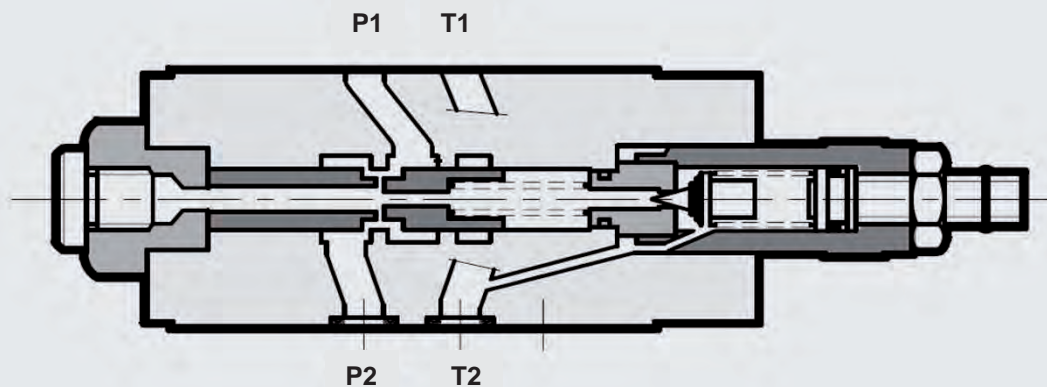

FUNCTION

The direct-acting pressure reducing valve in sandwich plate design in nominal size 10 is used to reduce the inlet pressure at P2 to a smaller outlet pressure P1. The pressure tapping for the reduced pressure is designed differently depending on the symbol:

- reduced pressure in port A → PA
- reduced pressure in port B → PB
- reduced pressure in port P → PT

The outlet pressure P1 can be tapped at measuring port (M).

Hint

In designs PA and PB, the pressure losses of the subsequent components must be considered when selecting the inlet pressure.

PERFORMANCE

measured at $v = 36 \text{ mm}^2/\text{s}$ and $T_{\text{oil}} = 50^\circ\text{C}$

Control

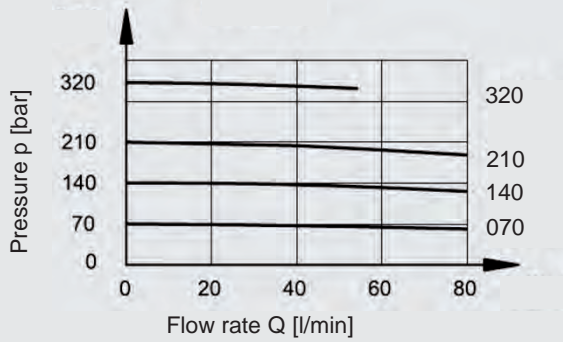

Pressure drop

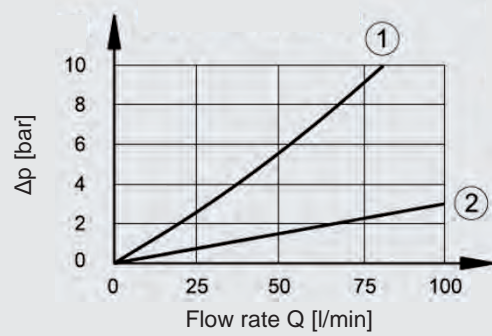

- 1) P2 → P1
- 2) Free lines

DIMENSIONS

Interface to ISO 4401-05-04-0-05
(Cetop 4.2-4-05-350)

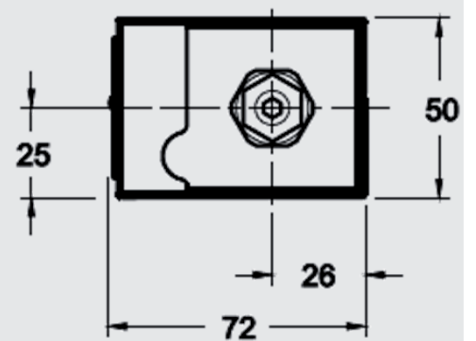
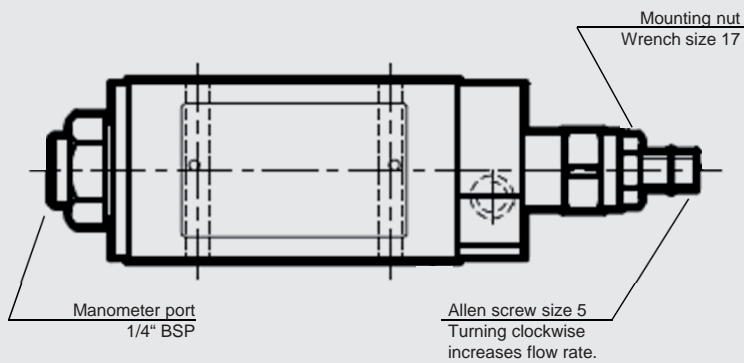
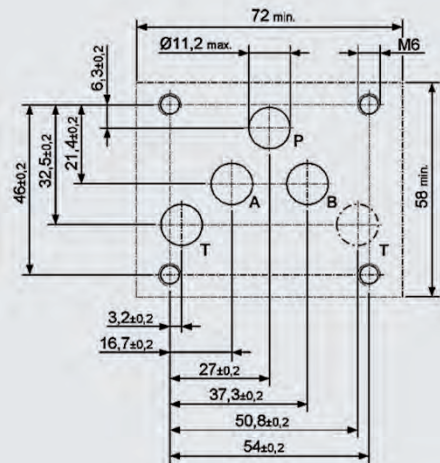
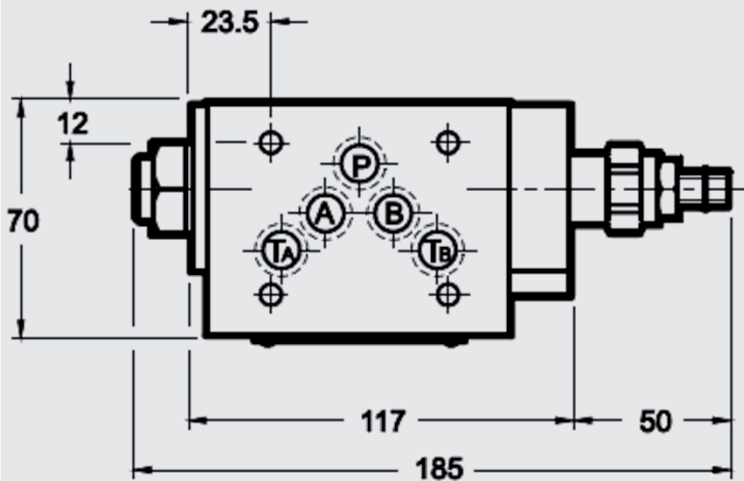

PRESSURE RELIEF VALVE IN SANDWICH PLATE DESIGN ZW – DB10



SUPPLEMENTARY TECHNICAL DATA

General specifications

Weight	[kg]	2.8
		3 (symbol AB and ABT)

Hydraulic specifications

Flow rate	[l/min]	120
-----------	---------	-----

MODEL CODE

ZW-DB 10 - D01 - AB 070 V - N

Type

Pressure relief valve in sandwich plate design, pilot-operated

Nominal size

10

Series

D01 = specified by manufacturer

Spool symbol

AB = pressure limiting in port B or A, outflow to port A or B
 AT = pressure limiting in port A, outflow to port T
 BT = pressure limiting in port B, outflow to port T
 PT = pressure limiting in port P, outflow to port T
 ABT = pressure limiting in port A and B, outflow to port T

Pressure ranges

070 = 6 to 70 bar
 140 = 6 to 140 bar
 210 = 6 to 210 bar
 350 = 6 to 350 bar

Adjustment types

V = adjustable using tool

Sealing material

N = NBR
 V = FKM (standard)

SPOOL TYPES / SYMBOLS

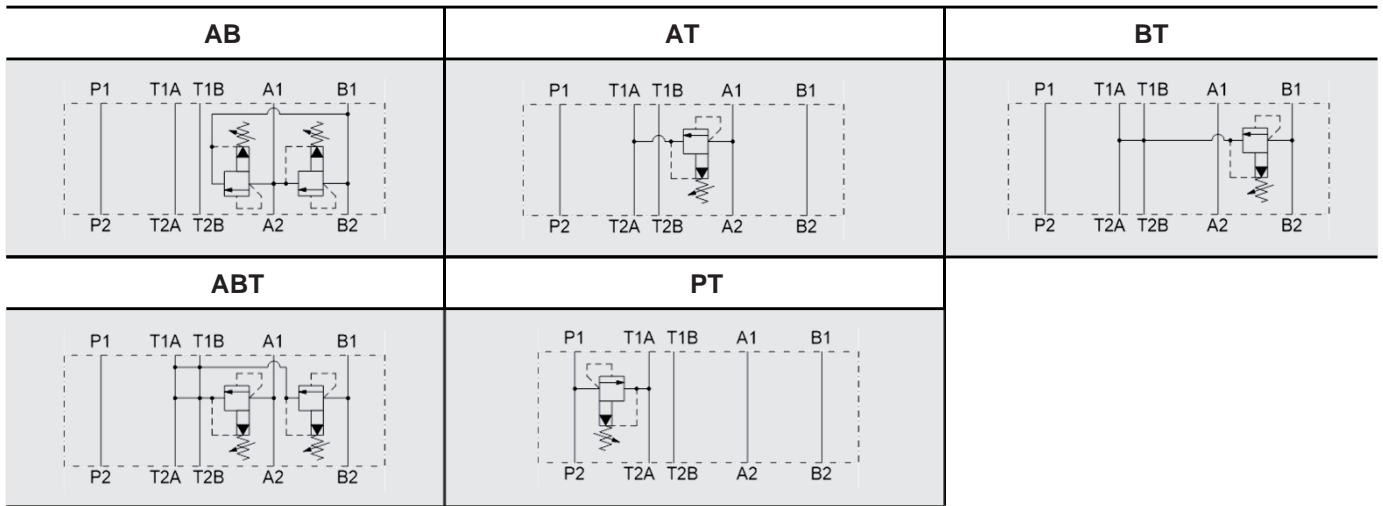

SECTION VIEW

Example PT

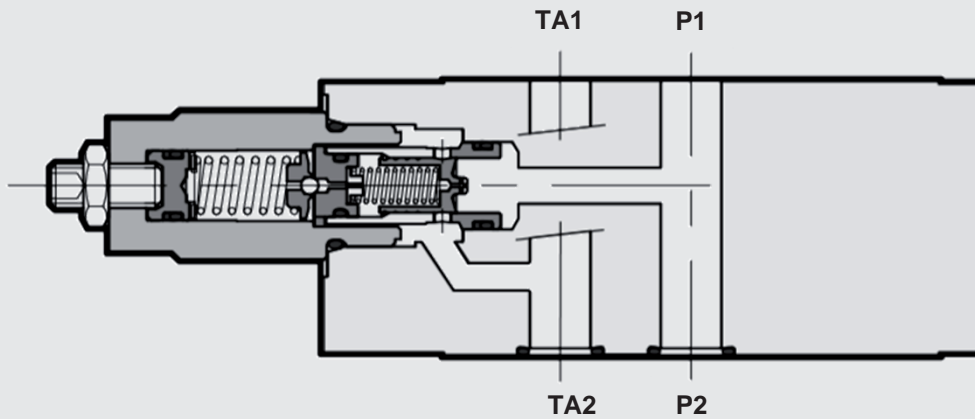

FUNCTION

The pressure relief valve in sandwich plate design in nominal size 10 is a pilot-operated spool valve, which limits the pressure in the system.

If the pressure at port P exceeds the pressure setting, the pilot poppet opens, so a small flow flows to the tank via pilot stage. Because of the resulting pressure difference, the main piston moves towards the return spring and allows flow from port P to T.

PERFORMANCE

measured at $v = 36 \text{ mm}^2/\text{s}$ and $T_{\text{oil}} = 50^\circ\text{C}$

Control

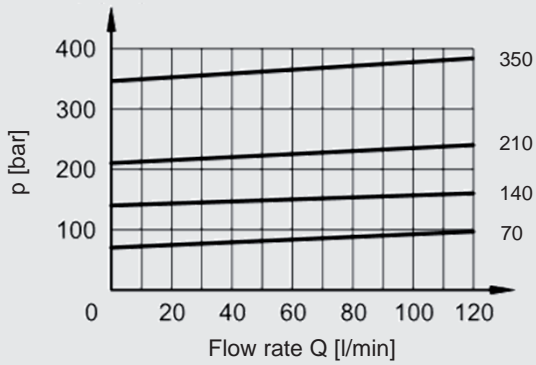

Pressure drop

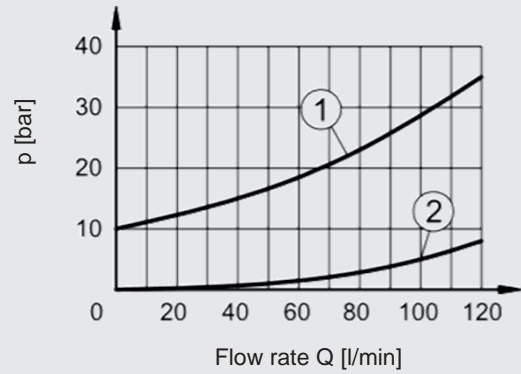

- 1) Controlled line symbol PT, AT, BT, ABT
- 2) Free line

DIMENSIONS

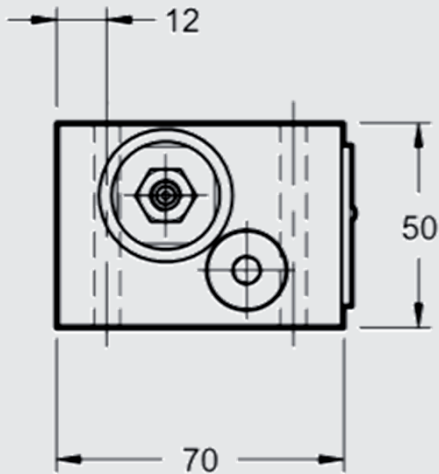

Interface to ISO 4401-05-04-0-05 (Cetop 4.2-4-05-350)

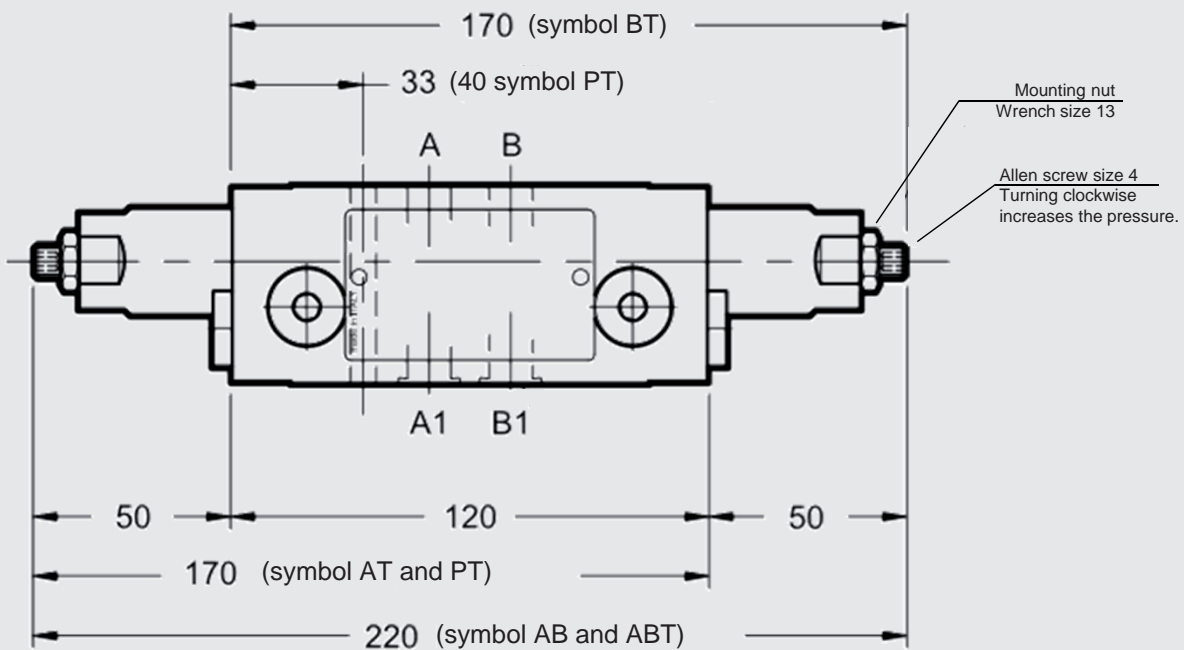
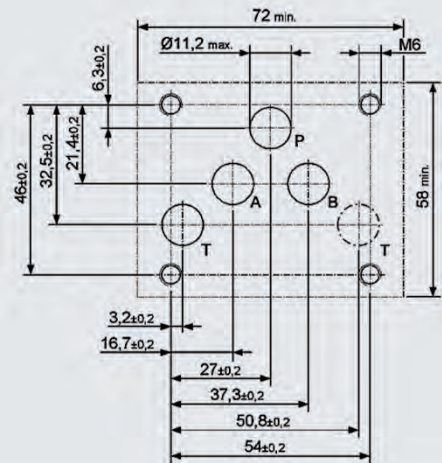

PRESSURE COMPENSATOR IN SANDWICH PLATE DESIGN ZW – DW10



SUPPLEMENTARY TECHNICAL DATA

General specifications

Weight [kg] 2.7

Hydraulic specifications

Flow rate [l/min] 100

MODEL CODE

ZW-DW 10 - 01 - PAB 4 - V

Type

Pressure compensator in sandwich plate design

Nominal size

10

Series

01 = specified by manufacturer

Spool symbol

PAB = 2-way pressure compensator

Pressure ranges

4 = 4 bar

8 = 8 bar

Sealing material

N = NBR

V = FKM (standard)

SPOOL TYPES / SYMBOLS

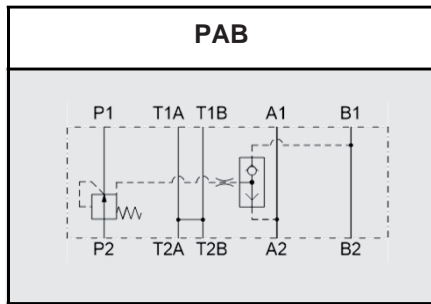

SECTION VIEW

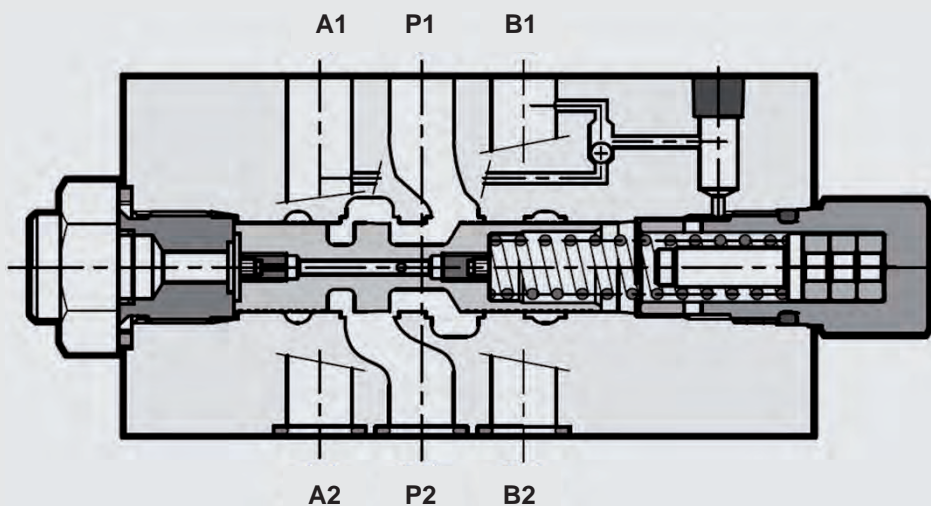

FUNCTION

The pressure compensator in sandwich plate design in nominal size 10 keeps the pressure loss constant between inlet P and – depending on the remote control of the integrated shuttle valve – the inlet to either consumer port A or B. In combination with a needle valve or proportional directional valve results in a constant flow rate to the consumer at port A or B. The control pressure of the pressure compensator can be specified between 4 and 8 bar depending on the design.

Application example for meter-in flow control at cylinder port A or B with a proportional directional valve:

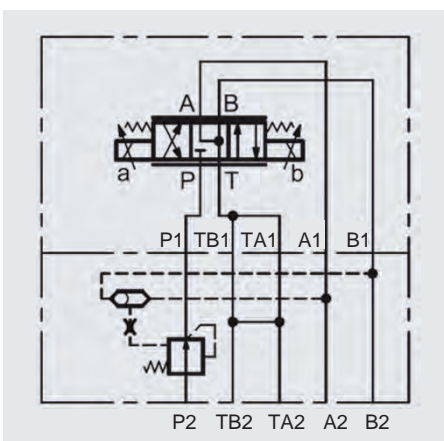

PERFORMANCE

measured at $v = 36 \text{ mm}^2/\text{s}$ and $T_{\text{oil}} = 50^\circ\text{C}$

2-way pressure compensator

Flow pressure $Q = f(p)$

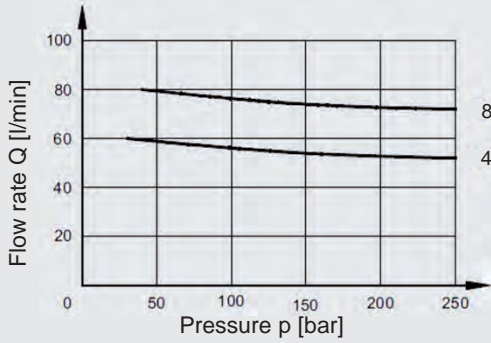

Pressure drop $\Delta p = f(Q)$

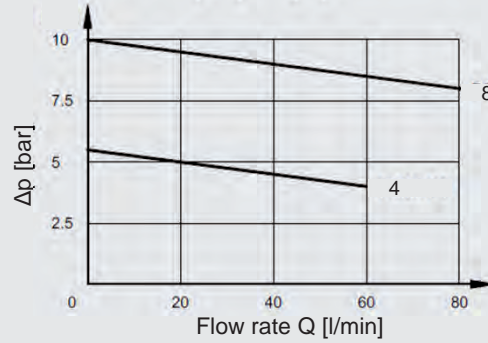

3-way pressure compensator

Flow pressure $Q = f(p)$

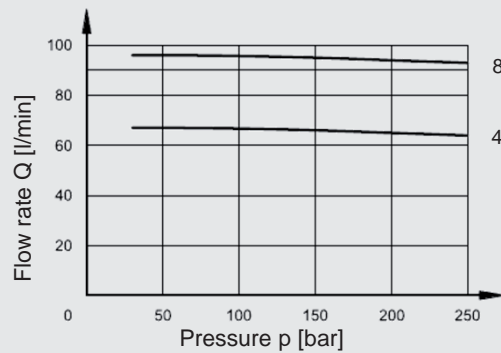

Pressure drop $\Delta p = f(Q)$

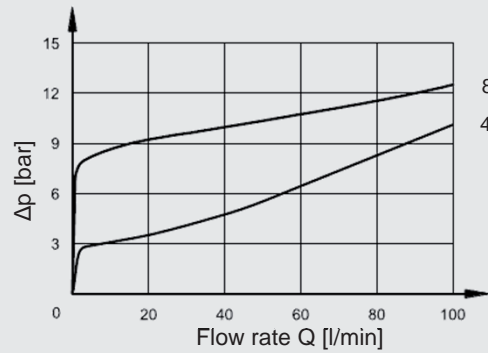

DIMENSIONS

Interface to ISO 4401-05-04-0-05
(Cetop 4.2-4-05-350)

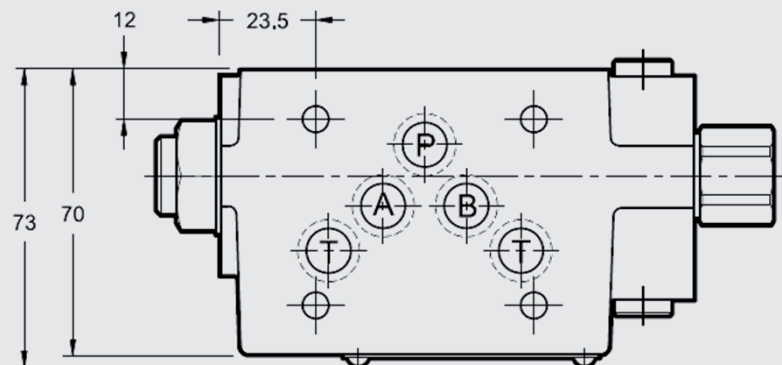
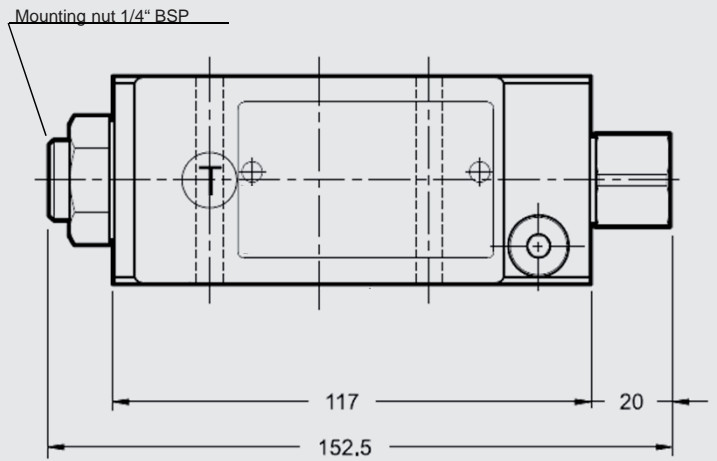
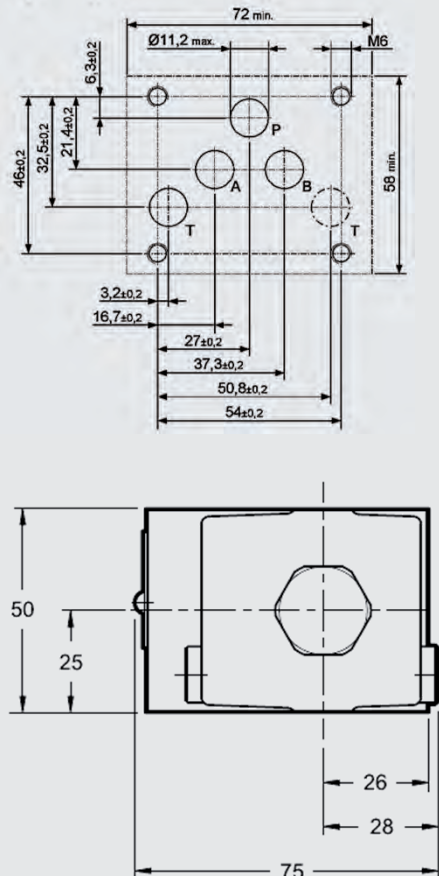

NEEDLE VALVE IN SANDWICH PLATE DESIGN ZW – SDR10



SUPPLEMENTARY TECHNICAL DATA

General specifications

Weight	[kg]	3.3
--------	------	-----

Hydraulic specifications

Cracking pressure	[bar]	0.4
-------------------	-------	-----

check valve

Flow rate	[l/min]	100
-----------	---------	-----

MODEL CODE

ZW-SDR 10 - 01 - AAB - N

Type

Needle valve in sandwich plate design

Nominal size

10

Series

01 = specified by manufacturer

Spool symbol

AAB = meter-out in port A and B
ZAB = meter-in in port A and B

Sealing material

N = NBR
V = FKM (standard)

SPOOL TYPES / SYMBOLS

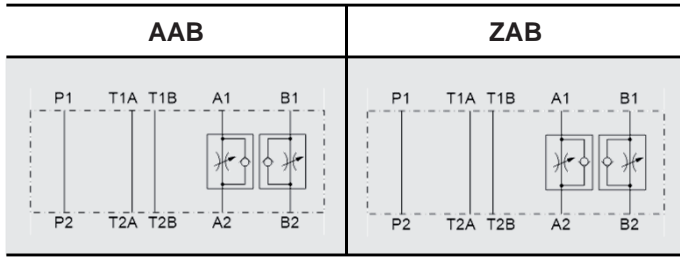

INSTALLATION EXAMPLE

Symbol AAB

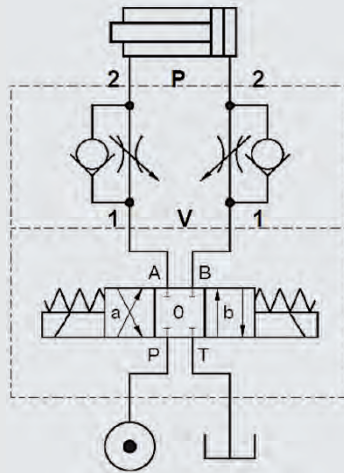

FUNCTION

The needle valve in sandwich plate design in nominal size 10 is used to control a flow rate in flow direction. In the reverse direction there is free flow through the valve if the cracking pressure is exceeded. The valve opens when the inlet pressure at the check valve is higher than the outlet pressure including the pressure spring force.

The throttling of the flow rate depends on the version:

- flow from consumer to directional valve in port A and B → AAB
- flow from consumer valve to actuator in port A and B → ZAB

PERFORMANCE

measured at $v = 32 \text{ mm}^2/\text{s}$ and $T_{\text{oil}} = 50^\circ\text{C}$

Pressure drop

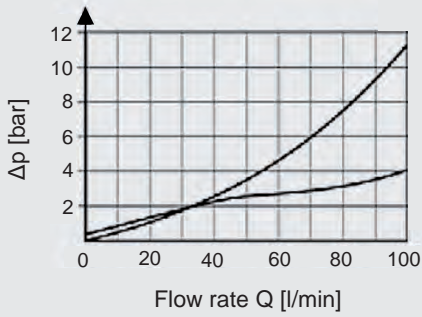

$P \rightarrow V$
Throttle completely open

$V \rightarrow P$
through check valve

DIMENSIONS

Interface to ISO 4401-05-04-0-05
(Cetop 4.2-4-05-350)

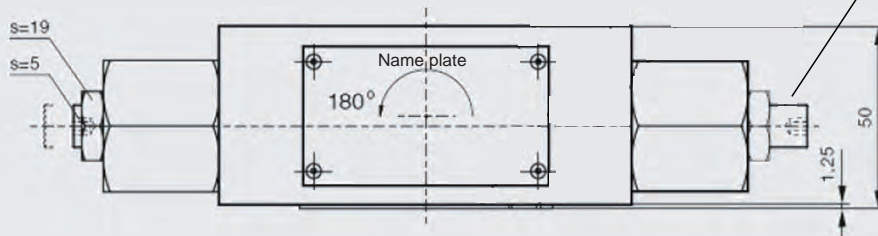
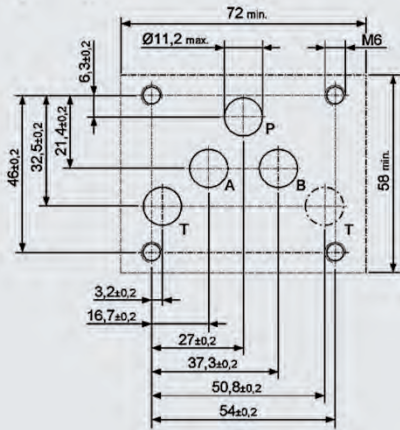

Throttle screw
Turning clockwise reduces flow rate.

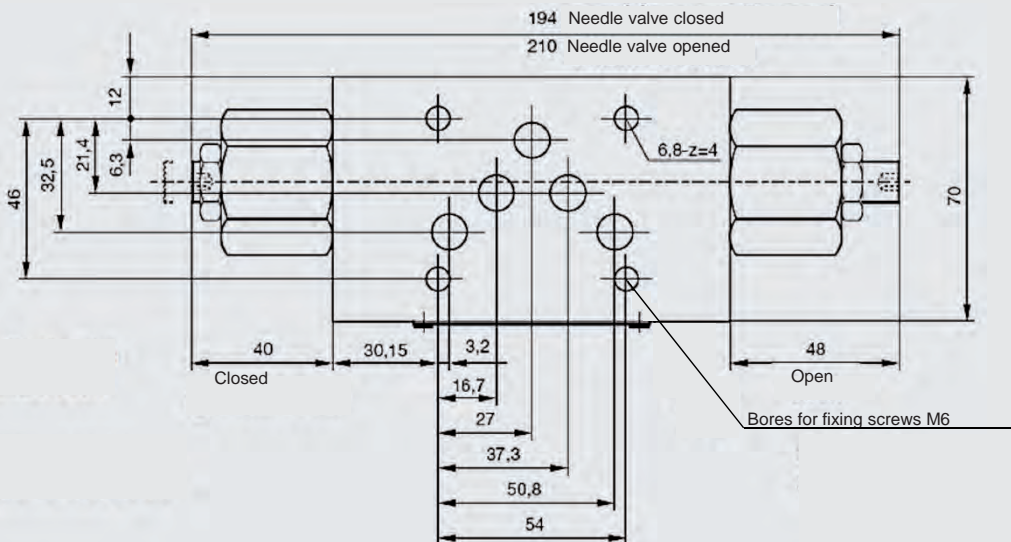

CHECK VALVE PILOT-TO-OPEN IN SANDWICH PLATE DESIGN ZW – RP10



SUPPLEMENTARY TECHNICAL DATA

General specifications

Weight	[kg]	3.5
--------	------	-----

Hydraulic specifications

Cracking pressure	[bar]	0.5
-------------------	-------	-----

Non-return valve		
------------------	--	--

Flow rate	[l/min]	100
-----------	---------	-----

Pilot ratio		3.6 : 1
-------------	--	---------

MODEL CODE

ZW-RP 10 - 01 - AA - N

Type

Check valve, pilot-to-open in sandwich plate design

Nominal size

10

Series

01 = specified by manufacturer

Spool symbol

AA = meter-out in port A

AB = meter-out in port B

AAB = meter-out in port A and B

Sealing material

N = NBR

V = FKM (standard)

SPOOL TYPES / SYMBOLS

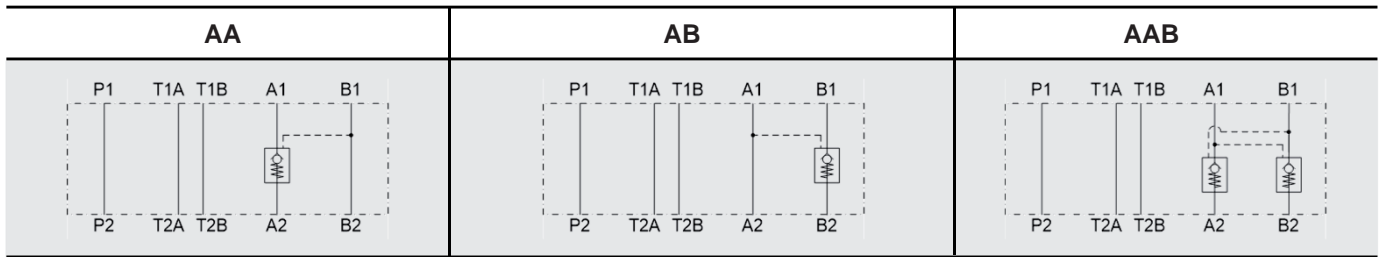

INSTALLATION EXAMPLE

Symbol AAB

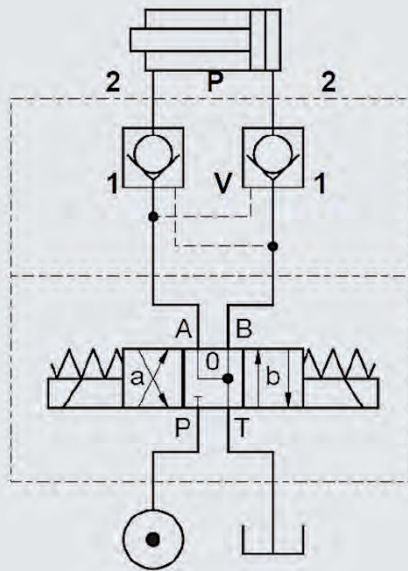

FUNCTION

The check valve, pilot-to-open in sandwich plate design in nominal size 10 is a direct-acting, spring-loaded poppet valve. It releases flow from the directional valve to the consumer and blocks flow from the consumer to the directional valve. To achieve this, the valve poppet is pressed into the seat and blocks the flow. If sufficiently high pilot pressure is built up in the relevant pilot port, the valve is unblocked and flow passes from the consumer to the directional valve. The required pilot pressure is based on the pressure difference between the ports to be unblocked.

Hint

A pressure in the port of the directional valve influences the required control pressure.

PERFORMANCE

measured at $v = 32 \text{ mm}^2/\text{s}$ and $T_{\text{oil}} = 50^\circ\text{C}$

Pressure drop

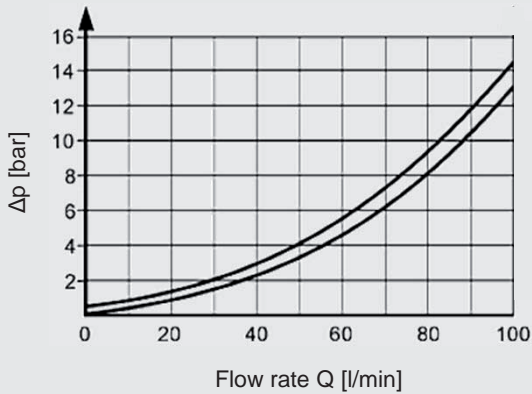

$V \rightarrow P$ (1 \rightarrow 2)
against spring force

$P \rightarrow V$ (2 \rightarrow 1)
pilot-operated

Use the following formula to calculate the min. required pilot pressure in port B:

$$p_{\text{control}} = \frac{p_{A2} - p_{A1}}{\phi} + p_{A1}$$

Use the following formula to calculate the min. required pilot pressure in port A:

$$p_{\text{control}} = \frac{p_{B2} - p_{B1}}{\phi} + p_{B1}$$

DIMENSIONS

Interface to ISO 4401-05-04-0-05
(Cetop 4.2-4-05-350)

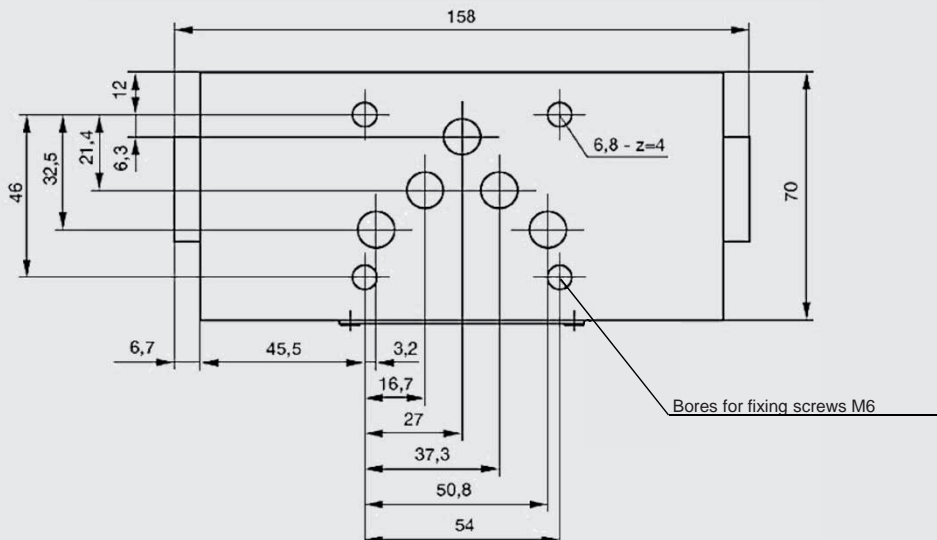
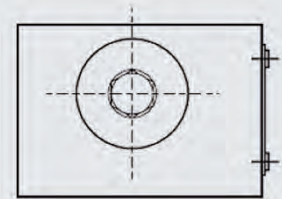
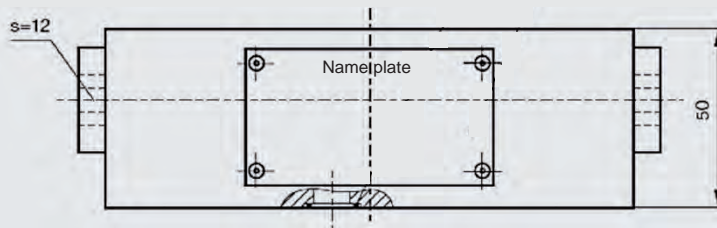
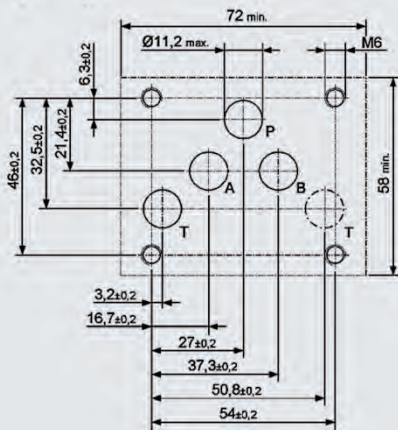

CHECK VALVE IN SANDWICH PLATE DESIGN ZW – RV10



SUPPLEMENTARY TECHNICAL DATA

General specifications

Weight [kg] 2.77

Hydraulic specifications

Cracking pressure [bar] 0.4
check valve

Flow rate [l/min] 100

MODEL CODE

ZW-RV 10 - 01 - A 0.4 - N

Type

Check valve in sandwich plate design

Nominal size

10

Series

01 = specified by manufacturer

Spool symbol

A = check valve in port A
B = check valve in port B
P = check valve in port P
T = check valve in port T

Cracking pressure

0.4 = 0.4 bar
Other cracking pressures on request

Sealing material

N = NBR
V = FKM (standard)

SPOOL TYPES / SYMBOLS

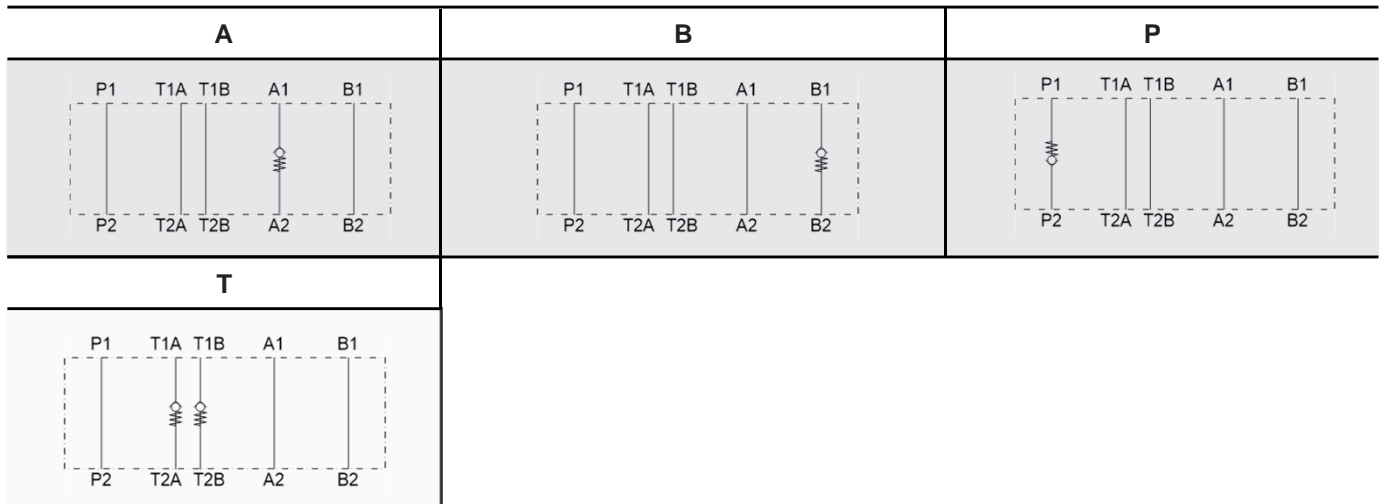

SECTION VIEW

Example P

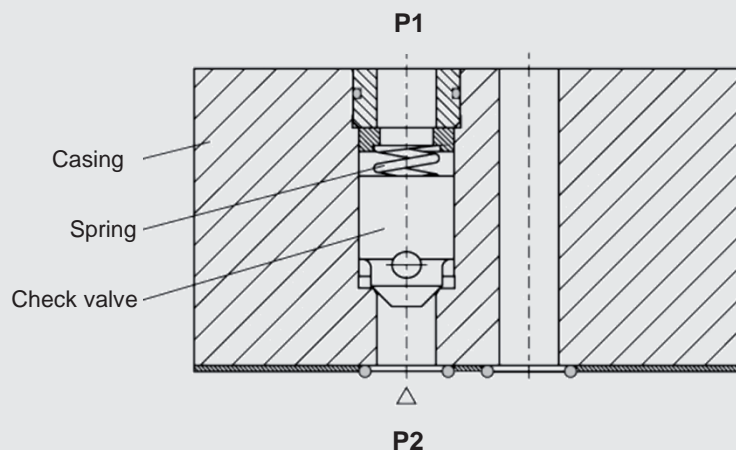

FUNCTION

The check valve in sandwich plate design in nominal size 10 is a direct-acting, spring-loaded poppet valve. It releases the flow in one direction after exceeding the pilot spring force and blocks it in the opposite direction. To achieve this, the valve poppet is pressed into the seat and blocks the flow.

- flow blocked in port A from consumer to directional valve → A
- flow blocked in port B from consumer to directional valve → B
- return flow blocked to fluid power supply → P
- preload of meter-out to tank → T

Hint

Spring-side pressures at the check element add to its cracking pressure.

PERFORMANCE

measured at $v = 32 \text{ mm}^2/\text{s}$ and $T_{\text{oil}} = 50^\circ\text{C}$

Pressure drop

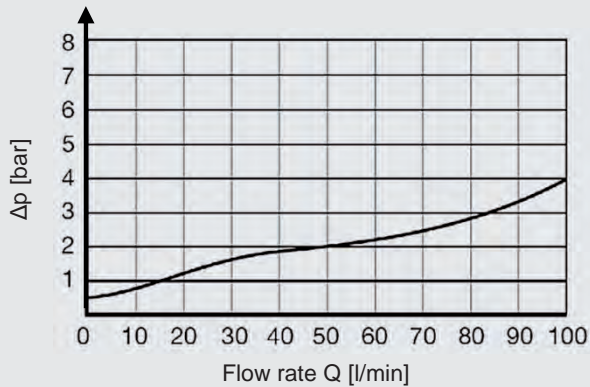

DIMENSIONS

Interface to ISO 4401-05-04-0-05
(Cetop 4.2-4-05-350)

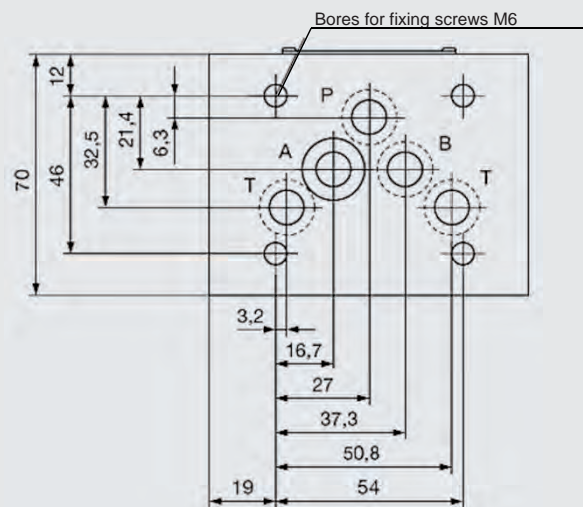
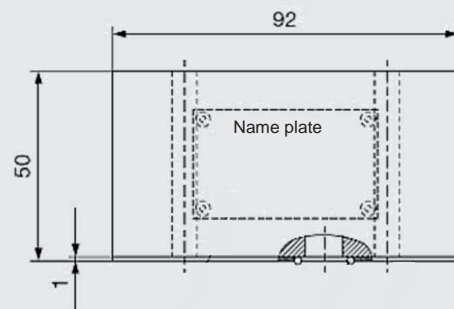
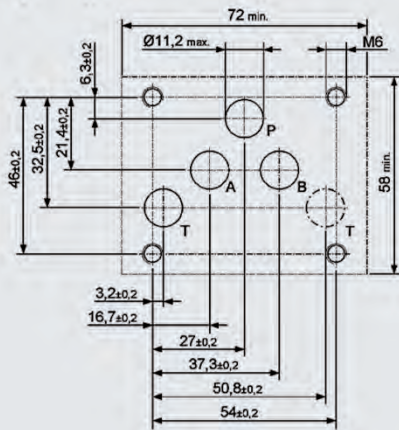

Note

The information in this brochure relates to the operating conditions and applications described. For applications or operating conditions not described, please contact the relevant technical department.
Subject to technical modifications.

ACCESSORIES

	Designation	Part no.
Seal kits (5-part set)	12.42 x 1.78 80 Sh NBR	3492434
	12.42 x 1.78 80 Sh FKM	3492433

HYDAC Fluidtechnik GmbH
Justus-von-Liebig-Str.
66280 Sulzbach/Saar, Germany
Tel: 0 68 97 /509-01
Fax: 0 68 97 /509-598
E-mail: valves@hydac.com

Valves in sandwich plate design Nominal size 16

DESCRIPTION

HYDAC valves in sandwich plate design in nominal size 16 enable modular design of the hydraulic control via stacked valve assembly.

We supply them as pressure reducing valve for pressure control, as needle valve for volume control and as check valve, pilot-to-open and non-pilot-to-open, for direction control.

The mounting elements are dependent on the modular design of your hydraulic control and are thus not included in the scope of delivery

FEATURES

- Available with pressure, flow and check function
- Modular design of hydraulic control
- Interface according to ISO 4401-07-07-0-05 (Cetop 7)



up to 300 l/min
up to 350 bar

TECHNICAL DATA*

General specifications		
Ambient temperature	[°C]	-20 to +60
Installation position		No orientation restrictions
Material		Casing: Cast iron Name plate: Aluminium
Surface coating		Valve casing: Phosphate plated
Hydraulic specifications		
Operating pressure	[bar]	350
Operating fluid		Hydraulic oil to DIN 51524 Part 1, 2 and 3
Temperature range of operating fluid	[°C]	-20 to +70
Viscosity	[mm ² /s]	15 to 400
Permitted contamination level of operating fluid		Class 20/18/15 according to ISO 4406
Sealing material		NBR (standard), FKM

* see "Conditions and Instructions for Valves" in brochure 53.000

CONTENTS

Directional valve

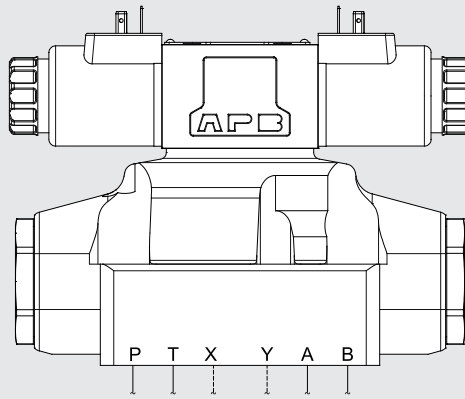

Pressure reducing valves

ZW-DM16...PA

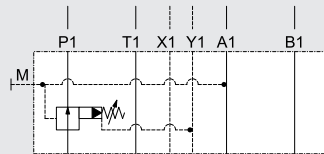

ZW-DM16...PB

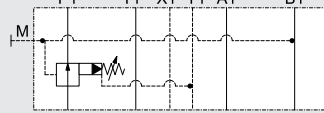

ZW-DM16...PT

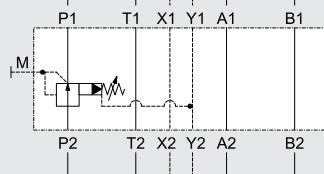

Check valves pilot-to-open

ZW-RP16...AA

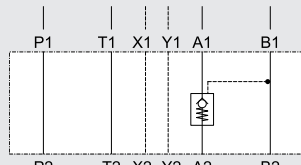

ZW-RP16...AB

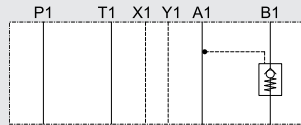

ZW-RP16...AAB

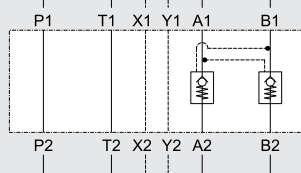

Check valves

ZW-RV16...P

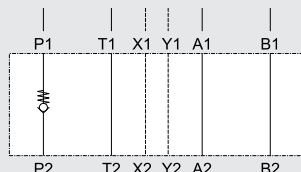

ZW-RV16...T

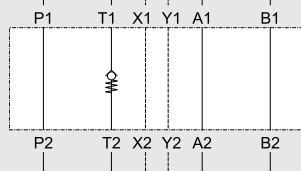

Needle valves

ZW-SDR16...AA

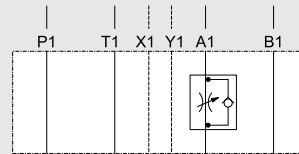

ZW-SDR16...ZA

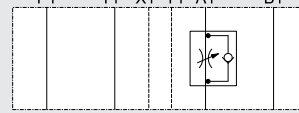

ZW-SDR16...AB

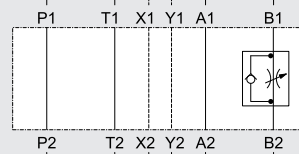

ZW-SDR16...ZB

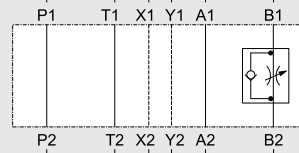

ZW-SDR16...AAB

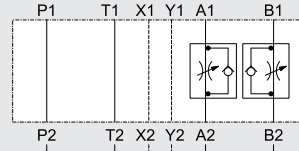

ZW-SDR16...ZAB

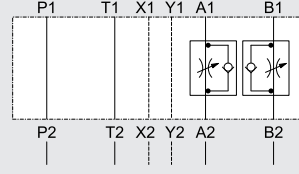

Accessories

PRESSURE REDUCING VALVE IN SANDWICH PLATE DESIGN ZW – DM16



SUPPLEMENTARY TECHNICAL DATA

General specifications		
Weight	[kg]	7.4
Hydraulic specifications		
Nominal flow	[l/min]	100 (pressure range 07/070) 300

MODEL CODE

ZW-DM 16 - 70 - PA - 070 V - N

Type

Pressure reducing valve in sandwich plate design, pilot-operated

Nominal size

16

Series

70 = specified by manufacturer

Spool symbol

PA = pressure control in port A
PB = pressure control in port B
PT = pressure control in port P

Pressure ranges

07/070 = 7 to 70 bar
070 = 15 to 70 bar
140 = 35 to 140 bar
250 = 70 to 250 bar

Adjustment types

V = adjustable using tool

Sealing material

N = NBR (standard)
V = FKM

SPOOL TYPES / SYMBOLS

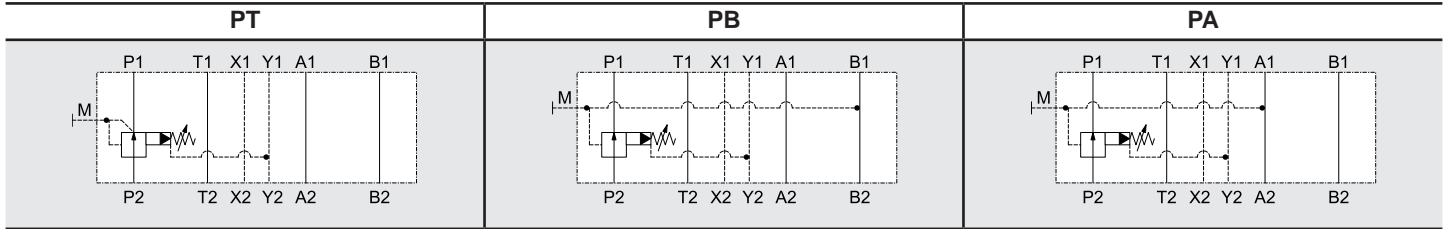

SECTION VIEW

Example PA

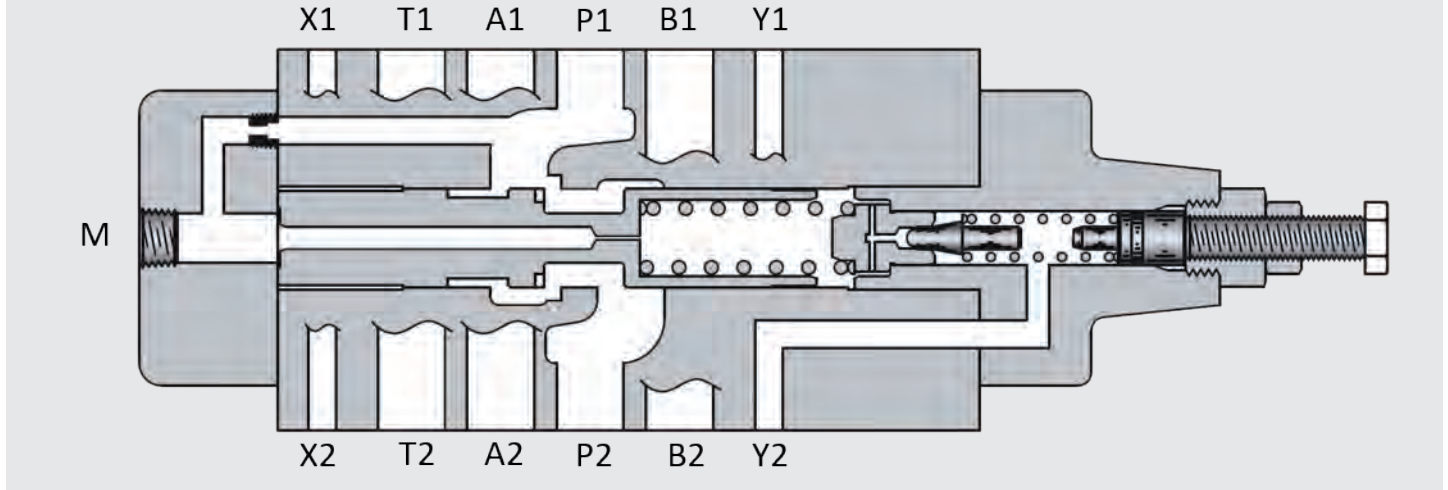

FUNCTION

The pilot-operated pressure reducing valve in spool valve design in nominal size 16 is used to reduce the inlet pressure at P2 to a smaller outlet pressure P1. The pressure tapping for the reduced pressure is designed differently depending on the symbol:

- reduced pressure in port A → PA
- reduced pressure in port B → PB
- reduced pressure in port T → PT

The outlet pressure P1 can be tapped at measuring port M.

Port Y is to be used and to be drained without pressure. Pressures at port Y are additive to the pressure setting.

Hint

In designs PA and PB, the pressure losses of the subsequent components must be considered when selecting the inlet pressure.

The casings have O-ring seals at the ports on the plate side.

PERFORMANCE

Measured at $v = 35 \text{ mm}^2/\text{s}$ and $T_{\text{oil}} = 45 \text{ }^\circ\text{C}$

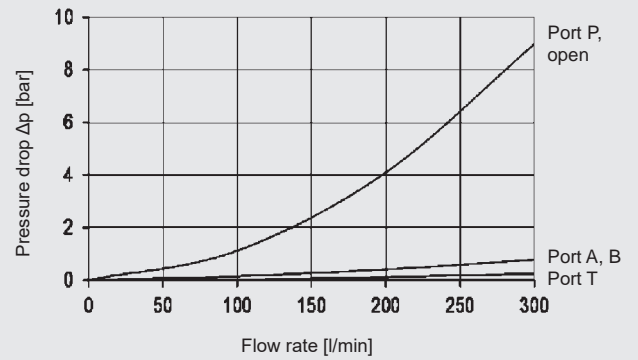
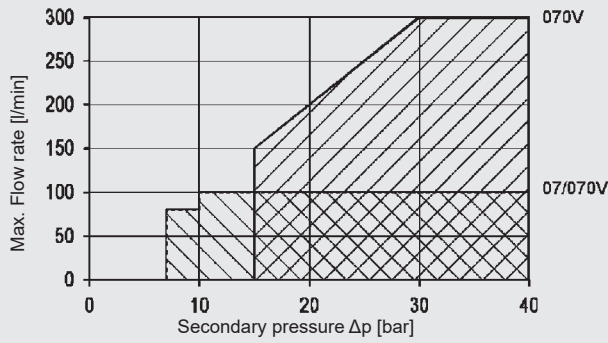
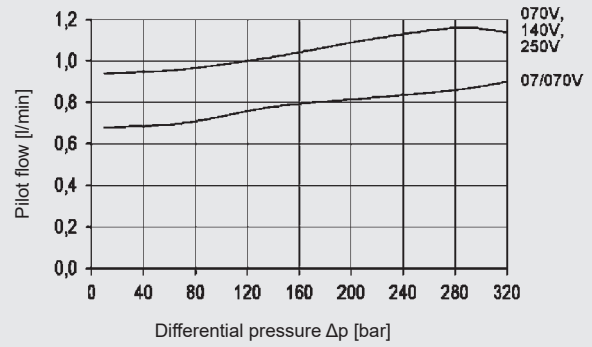
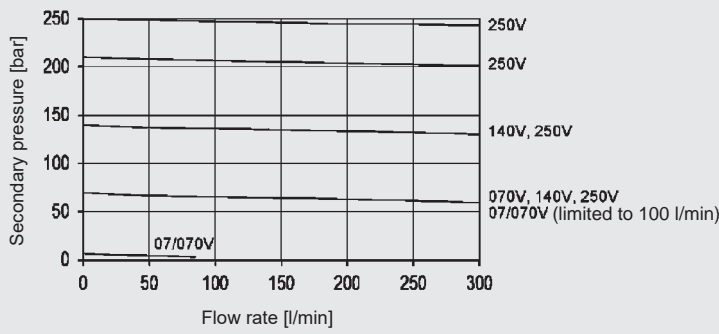

DIMENSIONS

Interface according to ISO 4401-07-07-0-05 (Cetop 7)

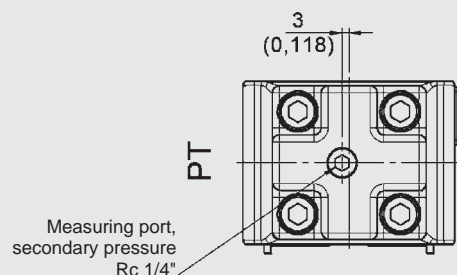
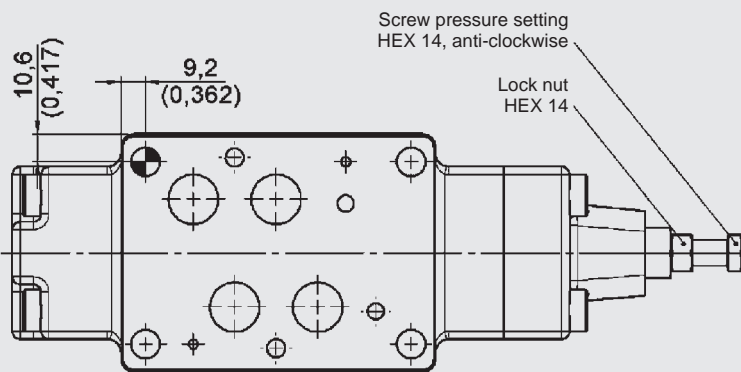
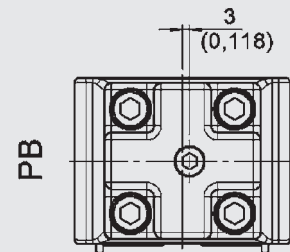
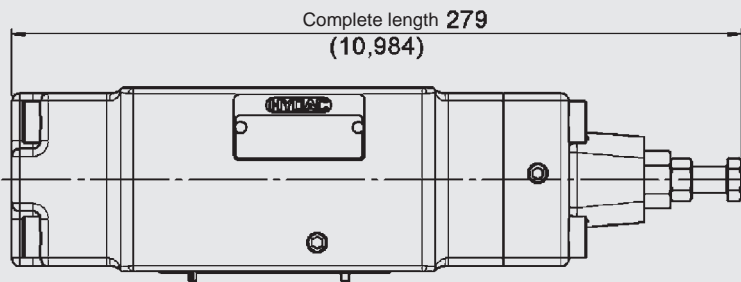
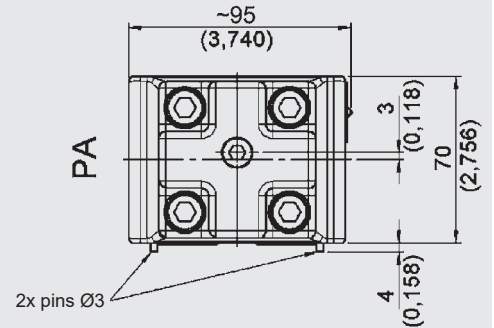
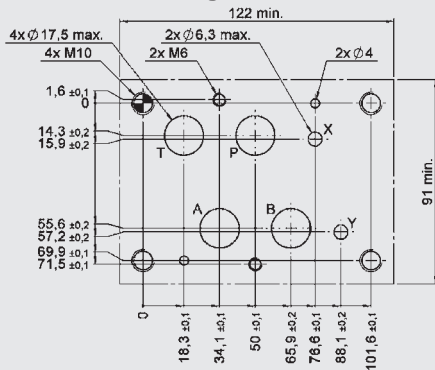

NEEDLE VALVE IN SANDWICH PLATE DESIGN ZW – SDR16



SUPPLEMENTARY TECHNICAL DATA

General specifications		
Weight	[kg]	7.4
		7.6 (symbols AAB and ZAB)
Hydraulic specifications		
Cracking pressure	[bar]	0.4
Nominal flow	[l/min]	300

MODEL CODE

ZW-SDR 16 - 70 - AA - N

Type

Needle valve in sandwich plate design, pilot-operated

Nominal size

16

Series

70 = specified by manufacturer

Spool symbol

AA = meter-out in port A
 AB = meter-out in port B
 AAB = meter-out in port A and B
 ZA = meter-in in port A
 ZB = meter-in in port B
 ZAB = meter-in in port A and B

Sealing material

N = NBR (standard)
 V = FKM

SPOOL TYPES / SYMBOLS

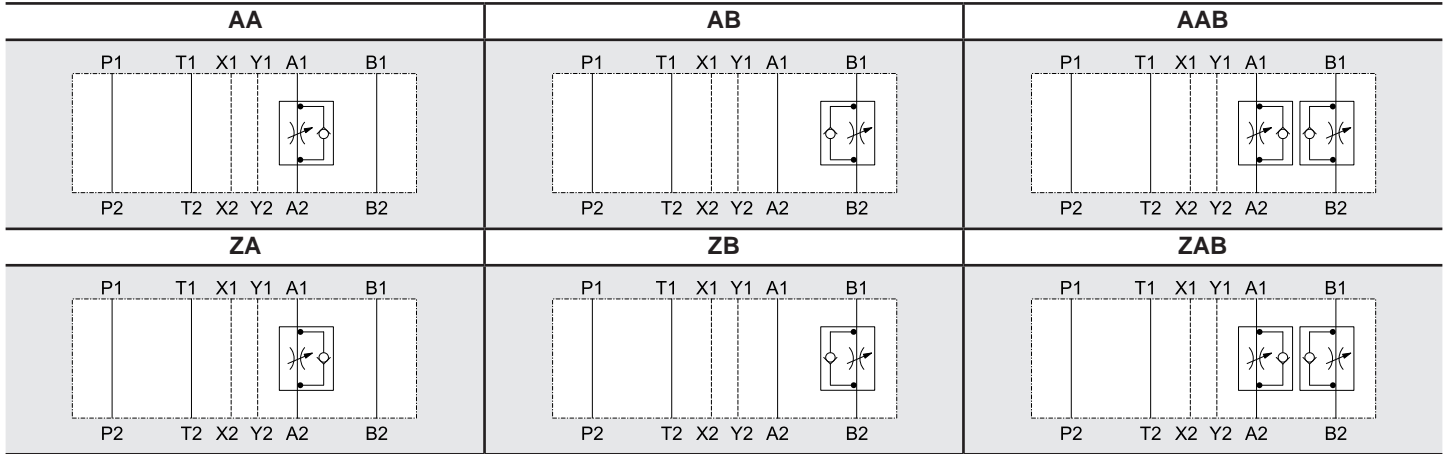

SECTION VIEW

Example ZAB

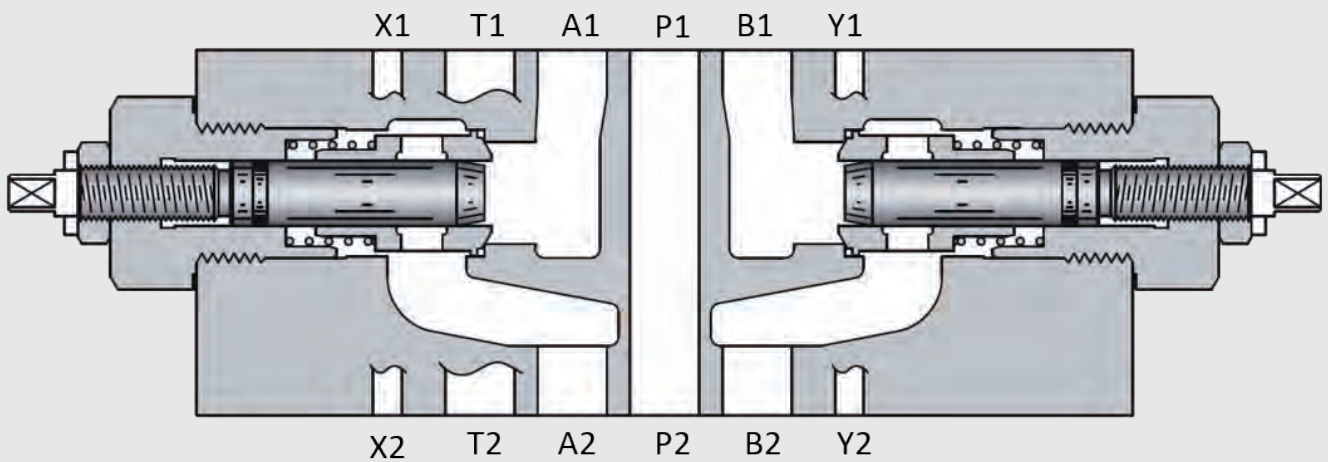

FUNCTION

The needle valve in nominal size 16 is used to control a flow rate in flow direction.

In the reverse direction there is free flow through the valve if the cracking pressure is exceeded. The valve opens when the inlet pressure at the check valve is higher than the outlet pressure including the pressure spring force.

The throttling of the flow rate depends on the version:

- flow from consumer to directional valve in port A → AA
- flow from consumer to directional valve in port B → AB
- flow from consumer to directional valve in port A and B → AAB
- flow from directional valve to consumer in port A → ZA
- flow from directional valve to consumer in port B → ZB
- flow from directional valve to consumer in port A and B → ZAB

Hint

The casings have O-ring seals at the ports on the plate side.

PERFORMANCE

Measured at $v = 35 \text{ mm}^2/\text{s}$ and $T_{\text{oil}} = 45 \text{ }^\circ\text{C}$

Pressure drop

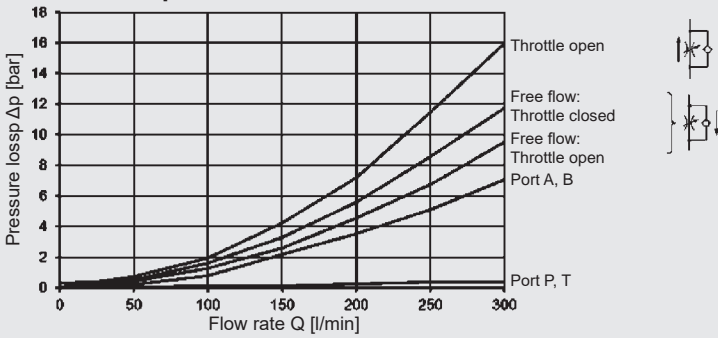

Measure flow rate vs. throttle position

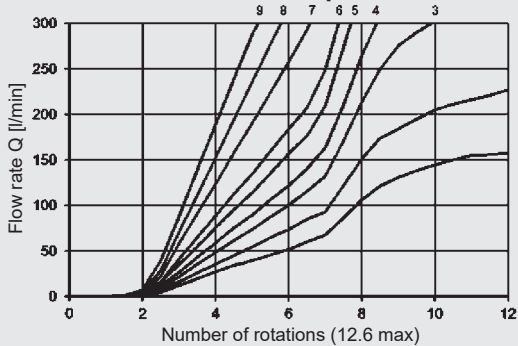

Curve	Measure flow rate vs. screw position
1	$\Delta p = 5 \text{ bar}$
2	$\Delta p = 10 \text{ bar}$
3	$\Delta p = 20 \text{ bar}$
4	$\Delta p = 30 \text{ bar}$
5	$\Delta p = 50 \text{ bar}$
6	$\Delta p = 70 \text{ bar}$
7	$\Delta p = 140 \text{ bar}$
8	$\Delta p = 210 \text{ bar}$
9	$\Delta p = 315 \text{ bar}$

DIMENSIONS

Interface according to ISO 4401-07-07-0-05 (Cetop 7)

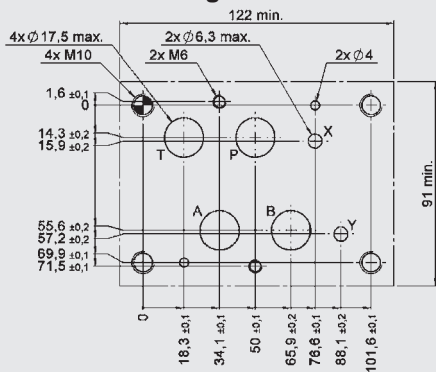

AAB, ZAB:

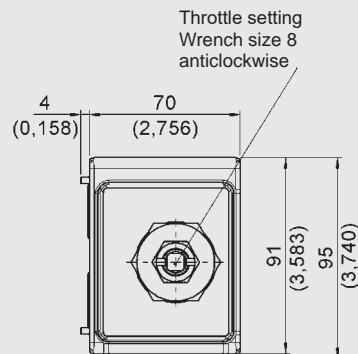
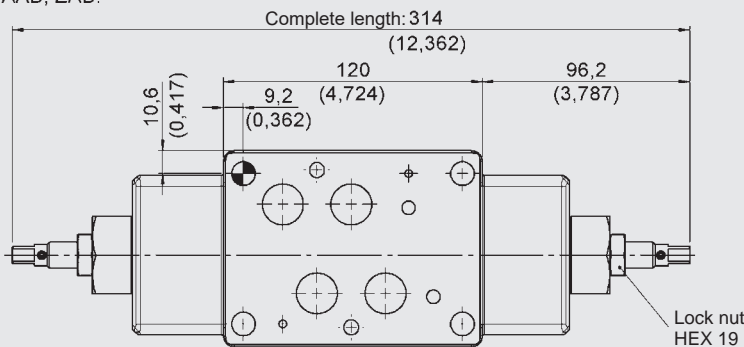

AA, ZA:

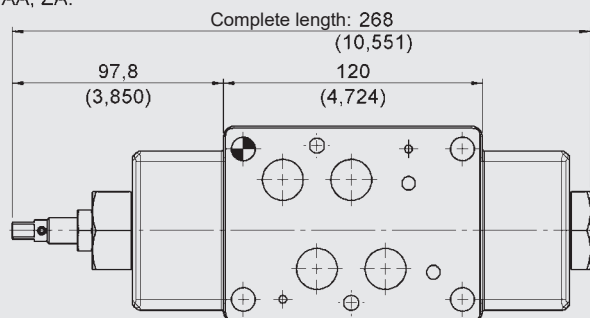

AB, ZB:

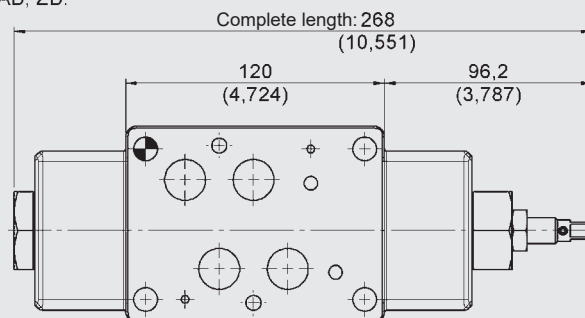

CHECK VALVE PILOT-TO-OPEN IN SANDWICH PLATE DESIGN ZW – RP16



SUPPLEMENTARY TECHNICAL DATA

General specifications		
Weight	[kg]	7.3
Hydraulic specifications		
Nominal flow	[l/min]	300
Pilot ratio		9.5 : 1

MODEL CODE

ZW-RP 16 - 70 - AA - 2 - N

Type

Check valve, pilot-to-open in sandwich plate design

Nominal size

16

Series

70 = specified by manufacturer

Spool symbol

AA = check function in port A

AB = check function in port B

AAB = check function in ports A and B

Cracking pressure

2 = 2 bar

4 = 4 bar

Sealing material

N = NBR (standard)

V = FKM

SPOOL TYPES / SYMBOLS

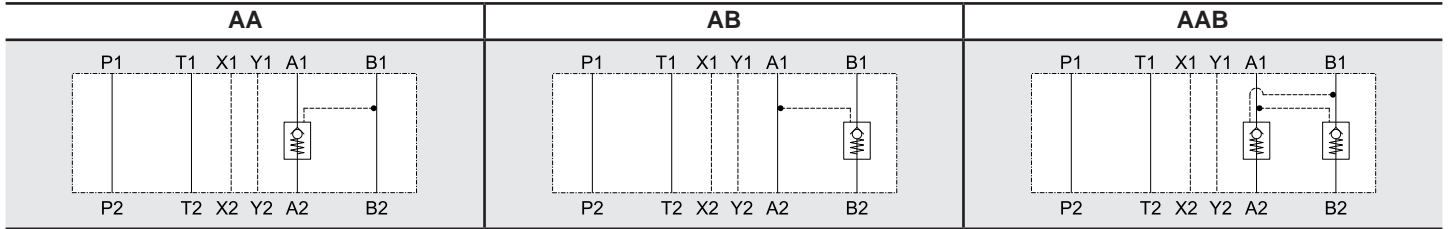

SECTION VIEW

Example AAB

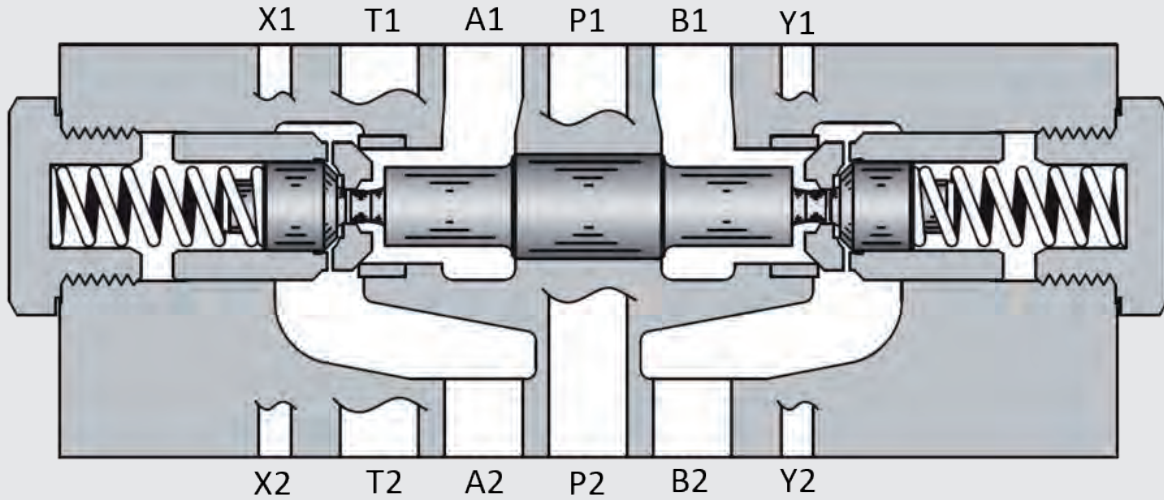

FUNCTION

The check valve, pilot-to-open in sandwich plate design in nominal size 16 is a direct-acting, spring-loaded poppet valve. It releases flow from the directional valve to the consumer and blocks flow from the consumer to the directional valve. To achieve this, the valve poppet is pressed into the seat and blocks the flow. If sufficiently high pilot pressure is built up in the relevant pilot port, the valve is unblocked and flow flows from the consumer to the directional valve. The required pilot pressure is based on the pressure difference between the ports to be unblocked.

NOTICE

The casings have O-ring seals at the ports on the plate side.

A pressure in the port of the directional valve influences the required control pressure.

PERFORMANCE

Measured at $v = 35 \text{ mm}^2/\text{s}$ and $T_{\text{oil}} = 45 \text{ }^\circ\text{C}$

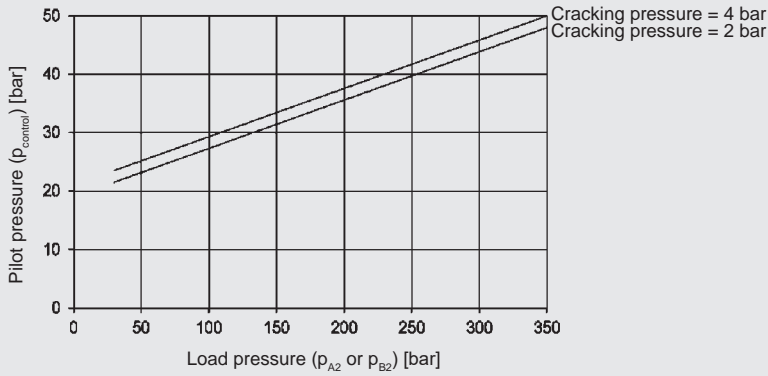
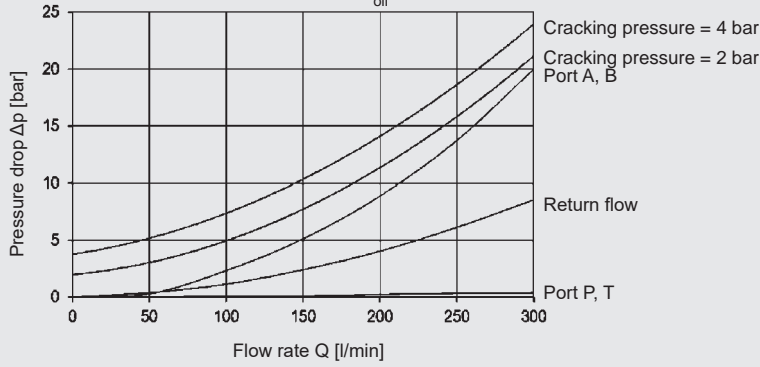

Use the following formula to calculate the min. required pilot pressure in port B:

$$p_{\text{control}} = \frac{p_{A2} - p_{A1}}{\varphi} + p_{A1}$$

Use the following formula to calculate the min. required pilot pressure in port A:

$$p_{\text{control}} = \frac{p_{B2} - p_{B1}}{\varphi} + p_{B1}$$

DIMENSIONS

Interface according to ISO 4401-07-07-0-05 (Cetop 7)

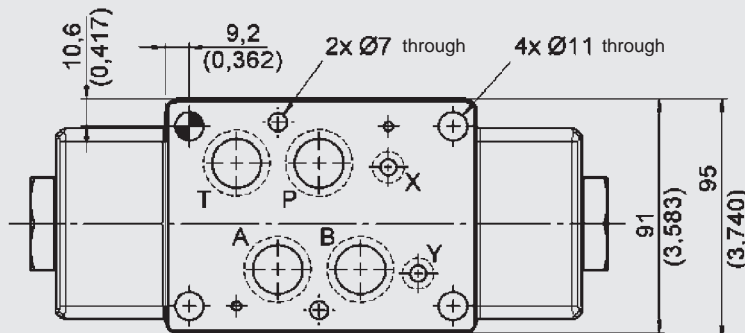
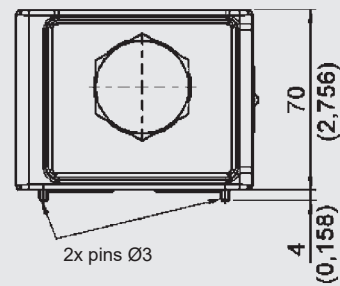
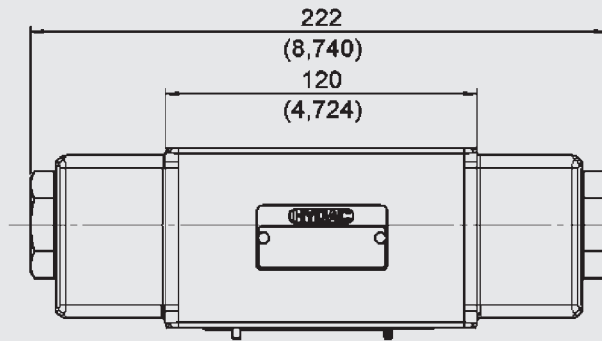
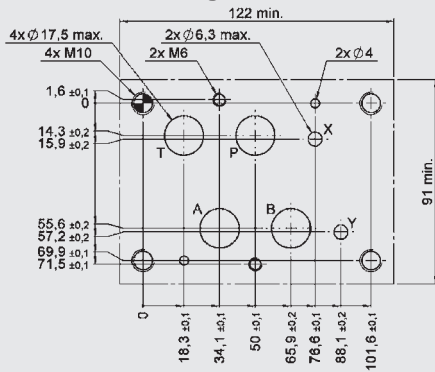

CHECK VALVE IN SANDWICH PLATE DESIGN ZW – RV16



SUPPLEMENTARY TECHNICAL DATA

General specifications		
Weight	[kg]	4.6 (symbol P) 5.4 (symbol T)
Hydraulic specifications		
Nominal flow	[l/min]	300

MODEL CODE

ZW-RV 16 - 70 - P - 2 - N

Type

Check valve in sandwich plate design

Nominal size

16

Series

70 = specified by manufacturer

Spool symbol

P = check valve in port P

T = check valve in port T

Cracking pressure

0.35 = 0.35 bar

2 = 2 bar

4 = 4 bar

Sealing material

N = NBR (standard)

V = FKM

SPOOL TYPES / SYMBOLS

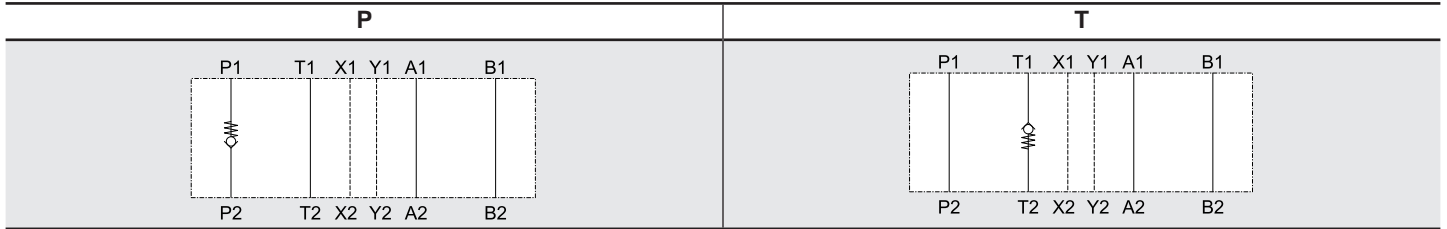

SECTION VIEW

Example T

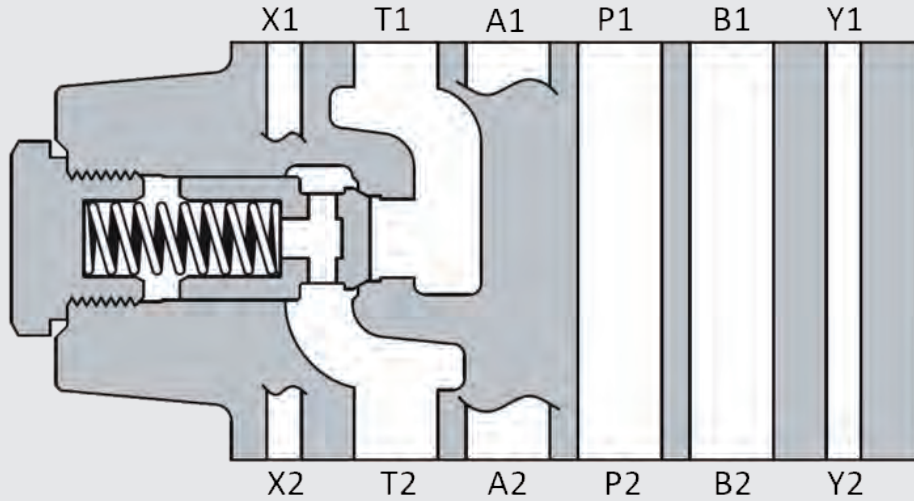

FUNCTION

The check valve in sandwich plate design in nominal size 16 is a direct-acting, spring-loaded poppet valve.

The valve releases a flow in one direction after exceeding the spring force and blocks the flow in the opposite direction. To achieve this, the valve poppet is pressed into the seat and blocks the flow.

- Version P: return flow blocked to fluid power supply
- Version T: preload of meter-out to tank

Hint

The casings have O-ring seals at the ports on the plate side.

Tank pressures in T2 are additive to the spring preload force.

PERFORMANCE

Measured at $v = 35 \text{ mm}^2/\text{s}$ and $T_{\text{oil}} = 45 \text{ }^\circ\text{C}$

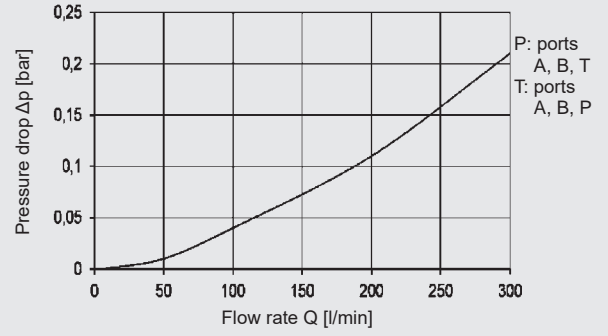
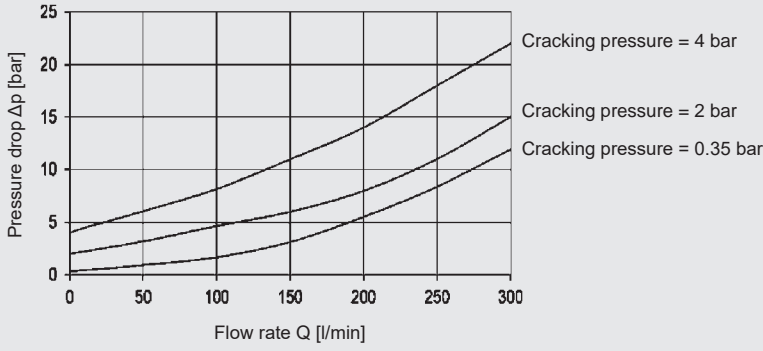

DIMENSIONS

Interface according to ISO 4401-07-07-0-05 (Cetop 7)

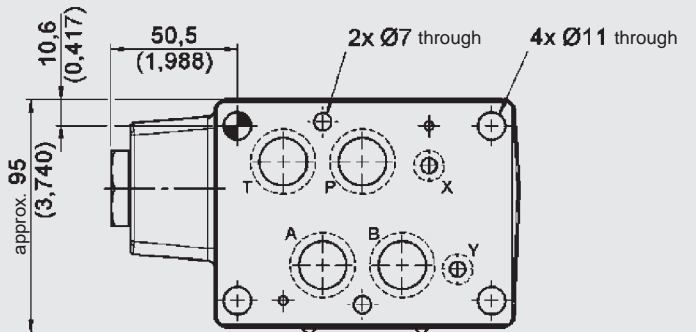
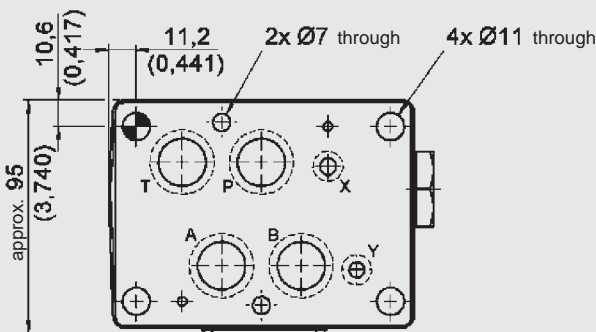
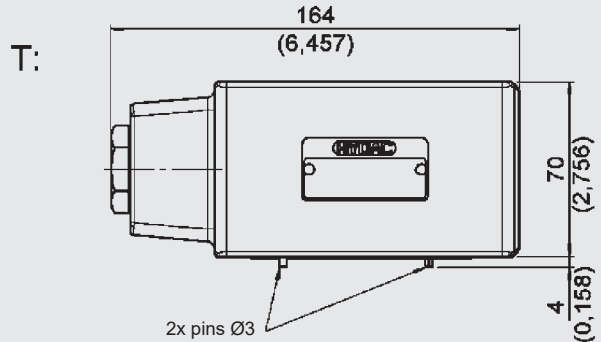
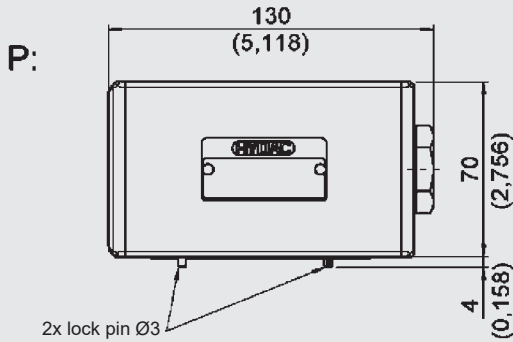
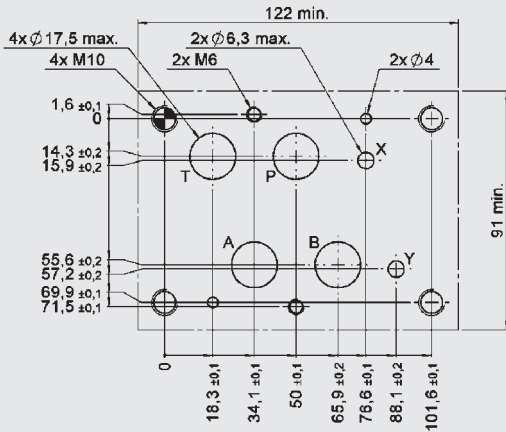

ACCESSORIES

	Designation	Part no.
Seal kits (6-part set)	22.22 x 2.62 -NBR -90 Sh (4 pieces)	3524553
	10.82 x 1.78 -NBR -90 Sh (2 pieces)	
	22.22 x 2.62 -FKM -90 Sh (4 pieces)	3524634
	10.82 x 1.78 -FKM -90 Sh (2 pieces)	

Note

The information in this brochure relates to the operating conditions and applications described.
For applications or operating conditions not described, please contact the relevant technical department.
Subject to technical modifications.

HYDAC Fluidtechnik GmbH
Justus-von-Liebig-Str.
66280 Sulzbach / Saar
Tel.: 06897 / 509 -01
Fax: 06897 / 509 -598
E-mail: valves@hydac.com

Valves in sandwich plate design Nominal size 25

DESCRIPTION

HYDAC valves in sandwich plate design in nominal size 25 enables a modular design of the hydraulic control via stacked valve assembly.

We offer them as pressure reducing valves to control pressure, as needle valves to control volume and as check valves, pilot-to-open and non-pilot-to-open.

TMounting elements dependent on the modular design of your hydraulic control and are thus not included in delivery.

FEATURES

- Available with pressure, flow and check function
- Modular design of hydraulic control
- Interface to ISO 4401-08-08-0-05 (Cetop 8)



up to 500 l/min
up to 350 bar

TECHNICAL DATA*

General specifications		
Ambient temperature	[°C]	-20 to +60
Installation position		No orientation restrictions
Material		Casing: Cast iron Name plate: Aluminium
Surface coating		Valve casing: Phosphate plated
Hydraulic specifications		
Operating pressure	[bar]	350
Operating fluid		Hydraulic oil to DIN 51524 Part 1, 2 and 3
Temperature range of operating fluid	[°C]	-20 to +70
Viscosity	[mm ² /s]	15 to 400
Permitted contamination level of operating fluid		Class 20/18/15 according to ISO 4406
Sealing material		NBR (standard), FKM

* see "Conditions and Instructions for Valves" in brochure 53.000

CONTENTS

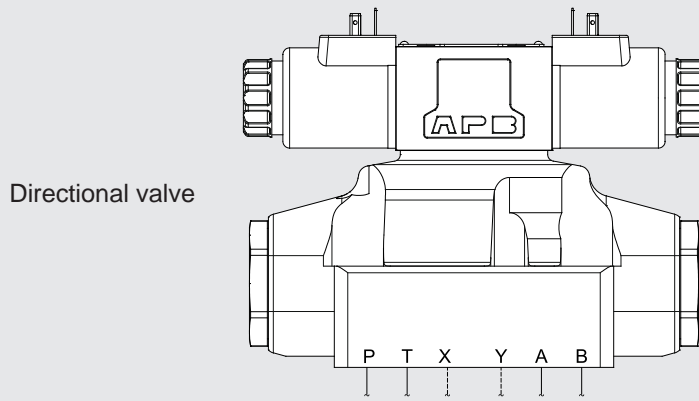

Pressure reducing valves

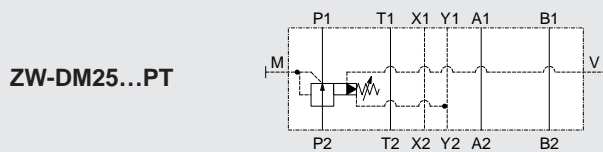
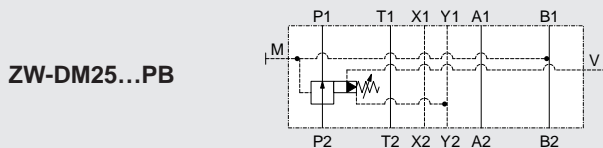
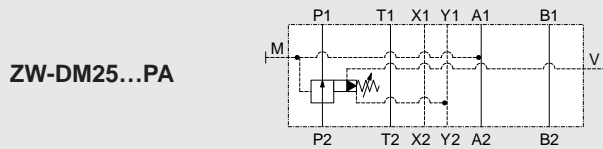

Check valves pilot-to-open

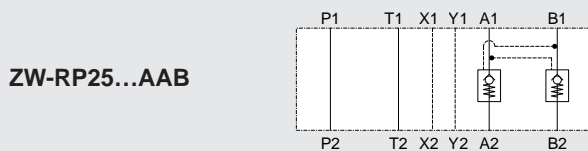
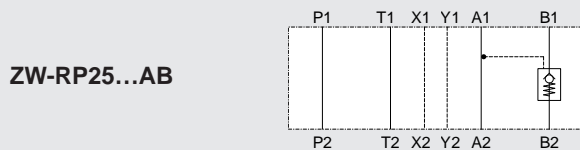
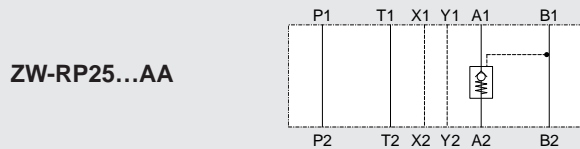

Needle valves

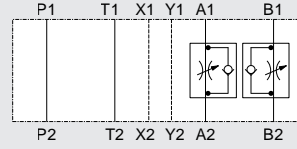
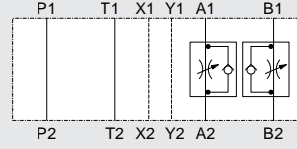
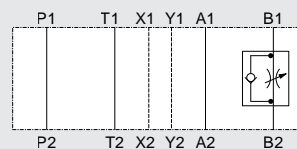
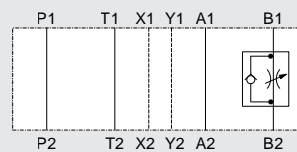
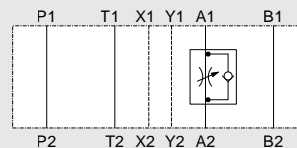
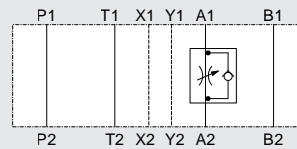

Accessories

PRESSURE REDUCING VALVE IN SANDWICH PLATE DESIGN ZW – DM25



SUPPLEMENTARY TECHNICAL DATA

General specifications		
Weight	[kg]	11.1
Hydraulic specifications		
Nominal flow	[l/min]	125 (pressure range 07/070) 500

MODEL CODE

ZW-DM 25 - 70 - PA - 070 V - N

Type

Pressure reducing valve in sandwich plate design, pilot-operated

Nominal size

25

Series

70 = specified by manufacturer

Spool symbol

PA = pressure control in port A
PB = pressure control in port B
PT = pressure control in port P

Pressure ranges

07/070 = 7 to 70 bar
070 = 15 to 70 bar
140 = 35 to 140 bar
250 = 70 to 250 bar

Adjustment types

V = adjustable using tool

Sealing material

N = NBR (standard)
V = FKM

SPOOL TYPES / SYMBOLS

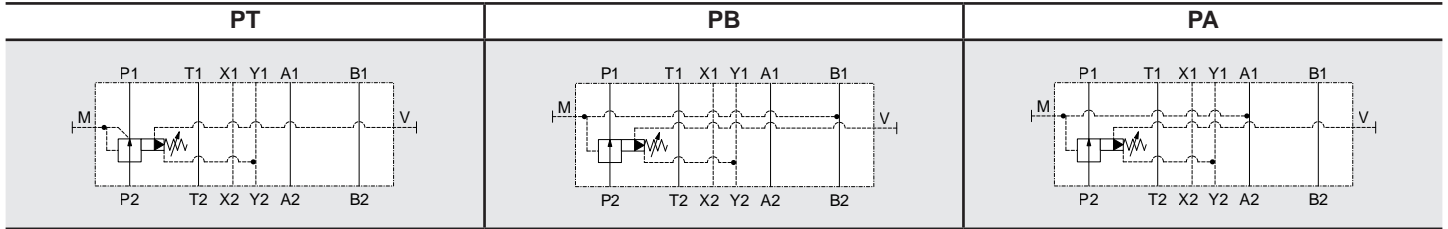

SECTION VIEW

Example PA

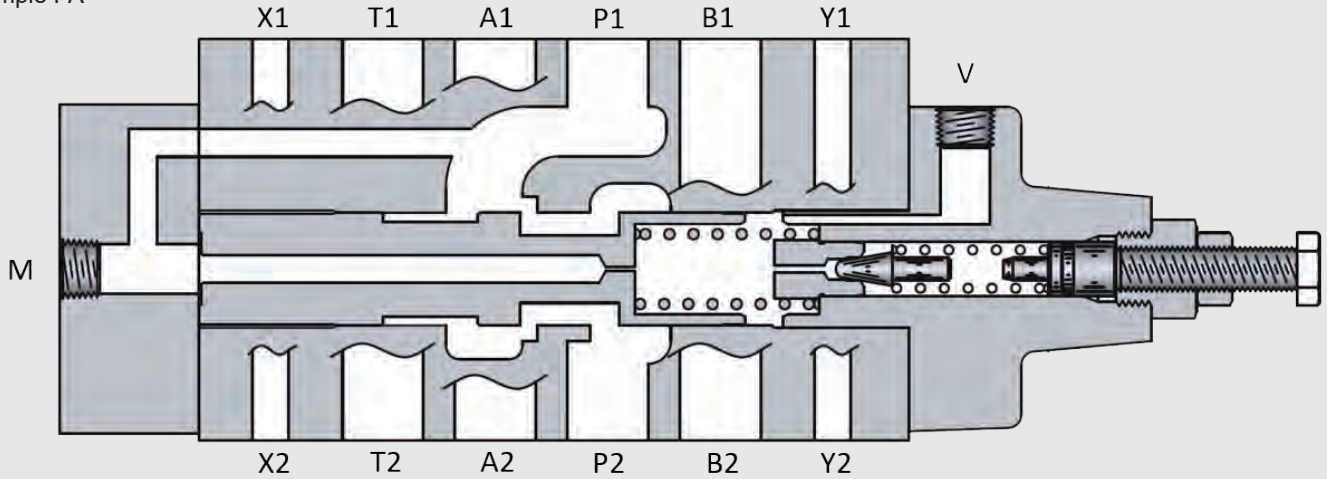

FUNCTION

The pilot-operated pressure reducing valve in spool valve design in nominal size 25 is used to reduce the inlet pressure at P2 to a smaller outlet pressure P1. The pressure tapping for the reduced pressure is designed differently depending on the symbol:

- reduced pressure in port A → PA
- reduced pressure in port B → PB
- reduced pressure in port T → PT

The outlet pressure P1 can be tapped at measuring port (M).

The remote control port V is used for pressure relief and thus to close the valve or to apply pressure and thus to control an external pressure level.

Port Y is to be used and to be drained without pressure. Pressures at port Y are additive to the pressure setting.

Hint

In designs PA and PB, the pressure losses of the subsequent components must be considered when selecting the inlet pressure.

The housings have O-ring seals at the ports on the plate side.

PERFORMANCE

Measured at $v = 35 \text{ mm}^2/\text{s}$ and $T_{\text{oil}} = 45 \text{ }^\circ\text{C}$

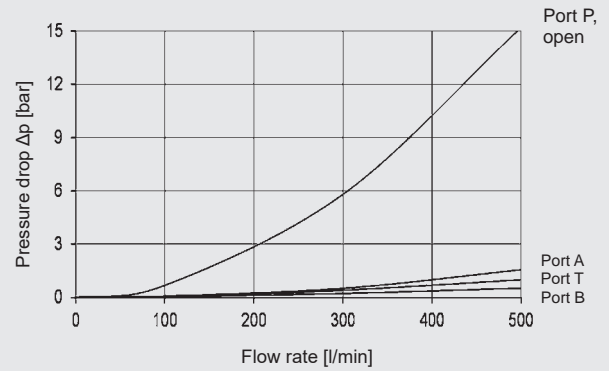
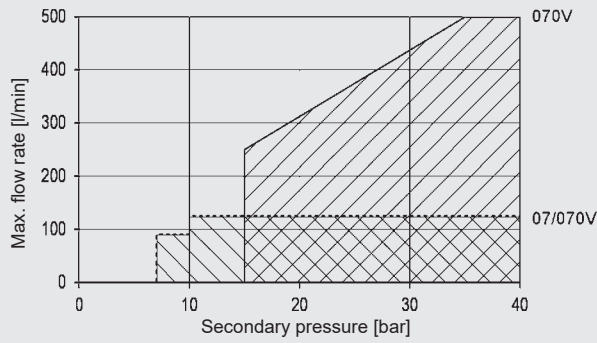
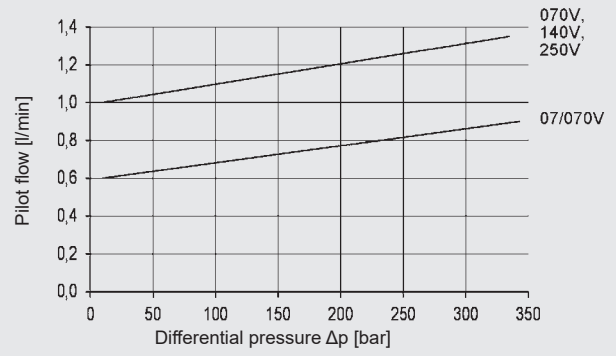
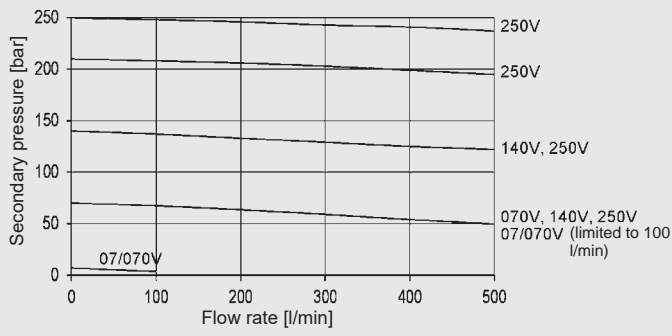

DIMENSIONS

Interface according to ISO 4401-08-08-0-05 (Cetop 8)

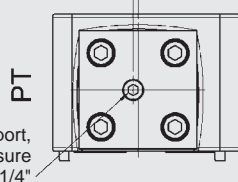
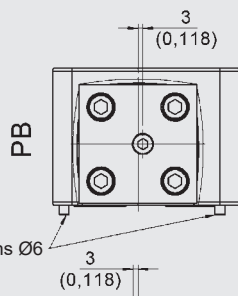
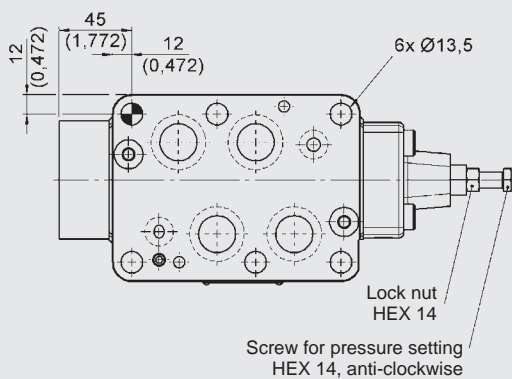
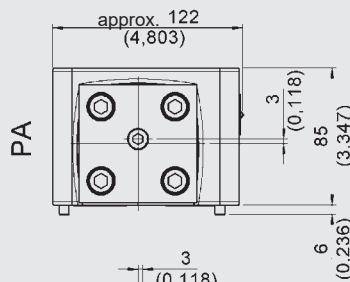
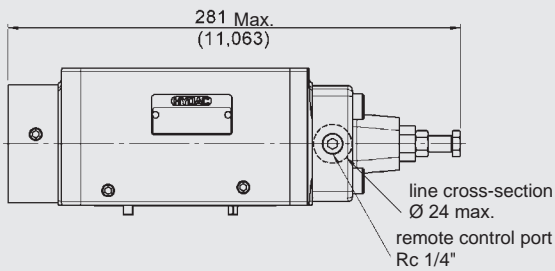
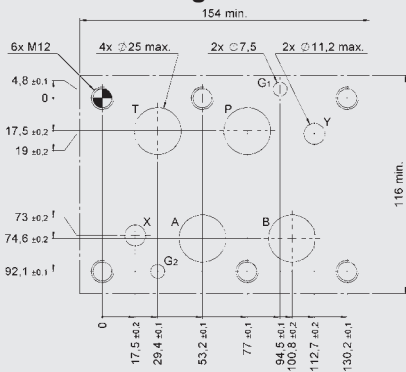

NEEDLE VALVE IN SANDWICH PLATE DESIGN ZW – SDR25



SUPPLEMENTARY TECHNICAL DATA

General specifications		
Weight	[kg]	12.0 12.2 (symbols AAB and ZAB)
Hydraulic specifications		
Cracking pressure	[bar]	0.49
Nominal flow	[l/min]	500

MODEL CODE

ZW-SDR 25 - 70 - AA - N

Type

Needle valve in sandwich plate design, pilot-operated

Nominal size

25

Series

70 = specified by manufacturer

Spool symbol

AA = meter-out in port A
 AB = meter-out in port B
 AAB = meter-out in port A and B
 ZA = meter-in in port A
 ZB = meter-in in port B
 ZAB = meter-in in ports A and B

Sealing material

N = NBR (standard)
 V = FKM

SPOOL TYPES / SYMBOLS

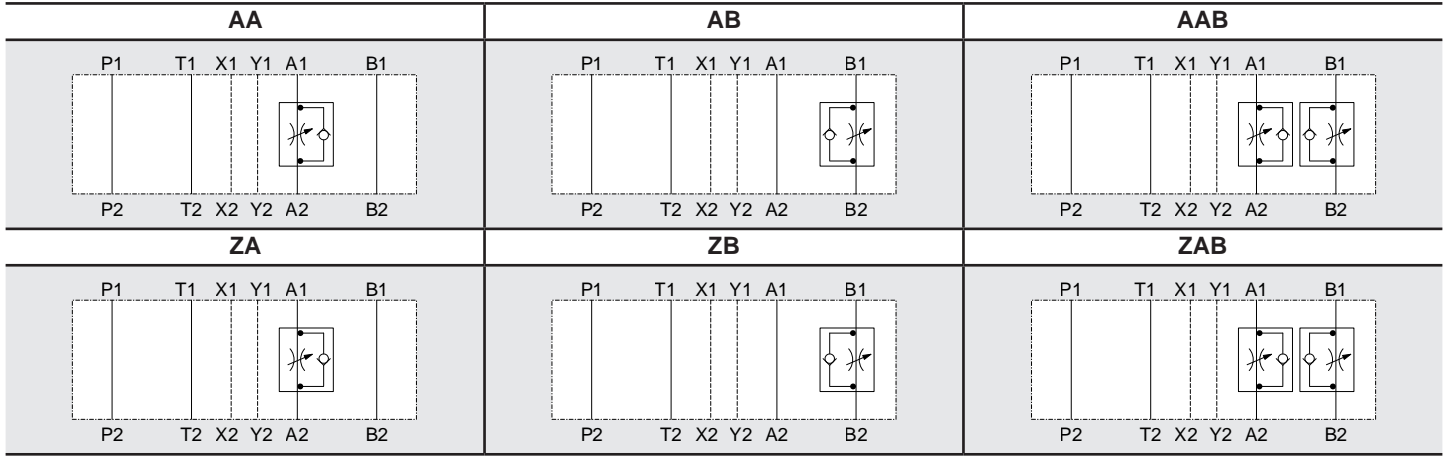

SECTION VIEW

Example ZAB

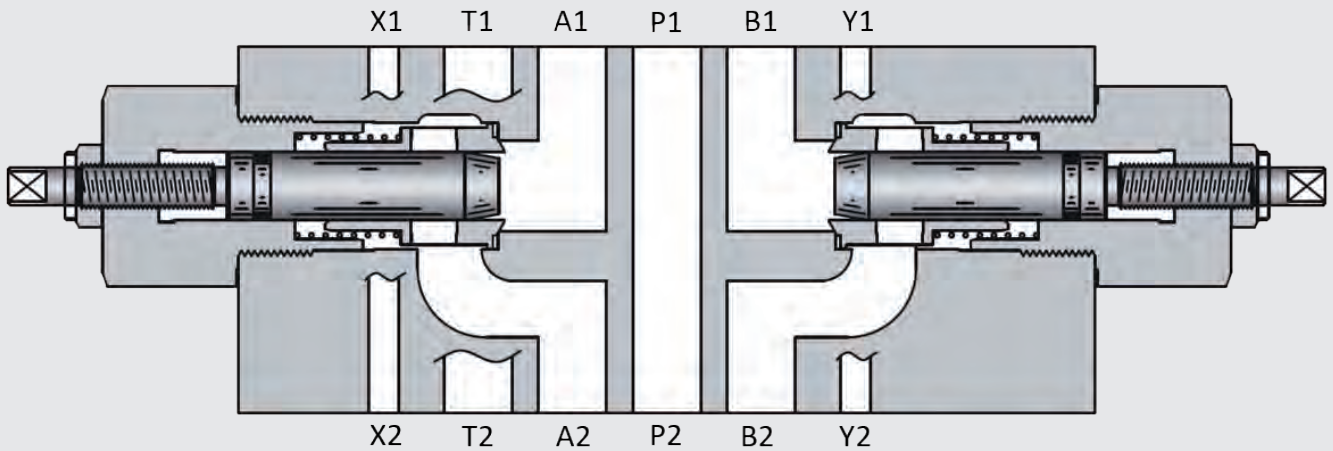

FUNCTION

The needle valve in nominal size 25 is used to control a flow rate in flow direction.

In the reverse direction there is free flow through the valve if the cracking pressure is exceeded. The valve opens when the inlet pressure at the check valve is higher than the outlet pressure including the pressure spring force.

The throttling of the flow rate depends on the version:

- flow from consumer to directional valve in port A → AA
- flow from consumer to directional valve in port B → AB
- flow from consumer to directional valve in port A and B → AAB
- flow from directional valve to consumer in port A → ZA
- flow from directional valve to consumer in port B → ZB
- flow from directional valve to consumer in port A and B → ZAB

Hint

The casings have O-ring seals at the ports on the plate side.

PERFORMANCE

Measured at $v = 35 \text{ mm}^2/\text{s}$ and $T_{\text{oil}} = 45 \text{ }^\circ\text{C}$

Pressure drop

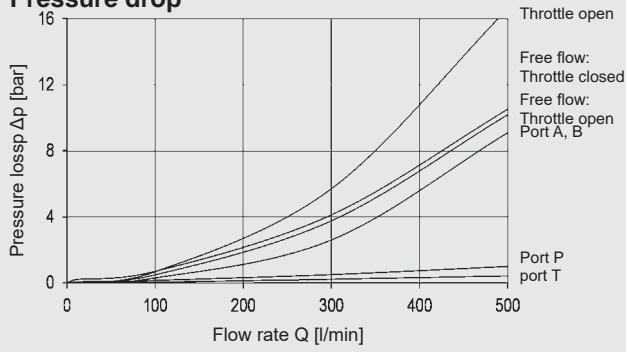

Measure flow rate vs. setting screw position

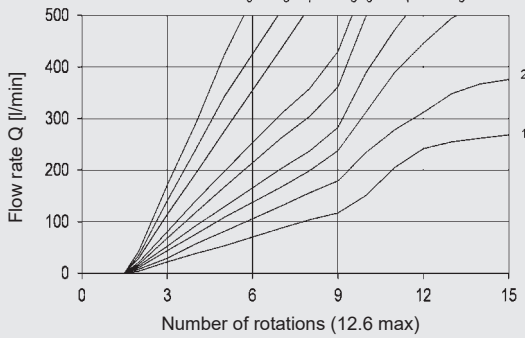

Curve	Measure flow rate vs. screw position
1	$\Delta p = 5 \text{ bar}$
2	$\Delta p = 10 \text{ bar}$
3	$\Delta p = 20 \text{ bar}$
4	$\Delta p = 30 \text{ bar}$
5	$\Delta p = 50 \text{ bar}$
6	$\Delta p = 70 \text{ bar}$
7	$\Delta p = 140 \text{ bar}$
8	$\Delta p = 210 \text{ bar}$
9	$\Delta p = 330 \text{ bar}$

DIMENSIONS

Interface according to ISO 4401-08-08-0-05 (Cetop 8)

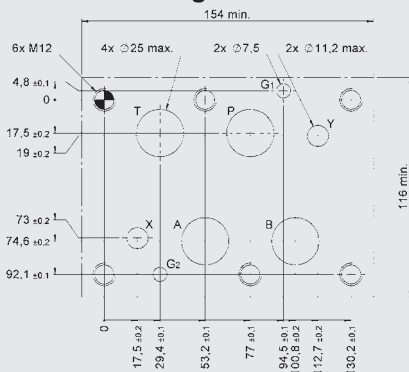

AAB, ZAB:

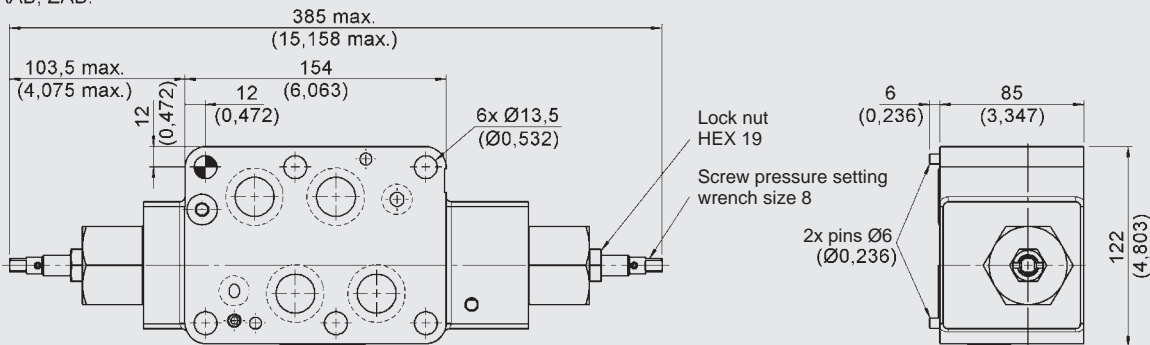

AA, ZA:

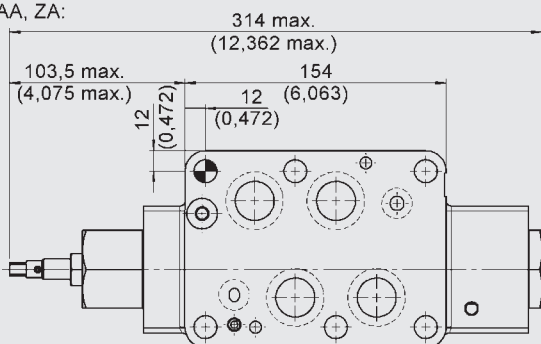

AB, ZB:

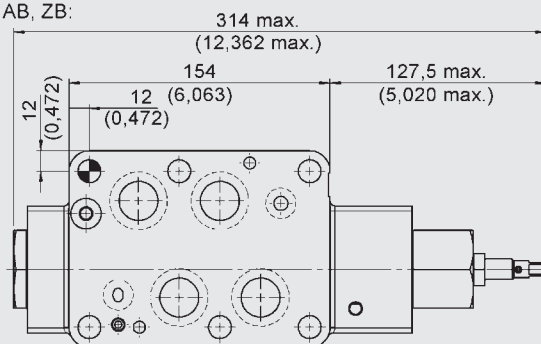

**CHECK VALVE PILOT-TO-OPEN
IN SANDWICH PLATE DESIGN
ZW – RP25**



SUPPLEMENTARY TECHNICAL DATA

General specifications		
Weight	[kg]	11.6
Hydraulic specifications		
Nominal flow	[l/min]	500
Pilot ratio		9.5 : 1

MODEL CODE

ZW-RP 25 - 70 - AA - 2 - N

Type

Check valve, pilot-to-open in sandwich plate design

Nominal size

25

Series

70 = specified by manufacturer

Piston symbol

AA = check function in port A

AB = check function in port B

AAB = check function in ports A and B

Cracking pressure

2 = 2 bar

4 = 4 bar

Sealing material

N = NBR (standard)

V = FKM

SPOOL TYPES / SYMBOLS

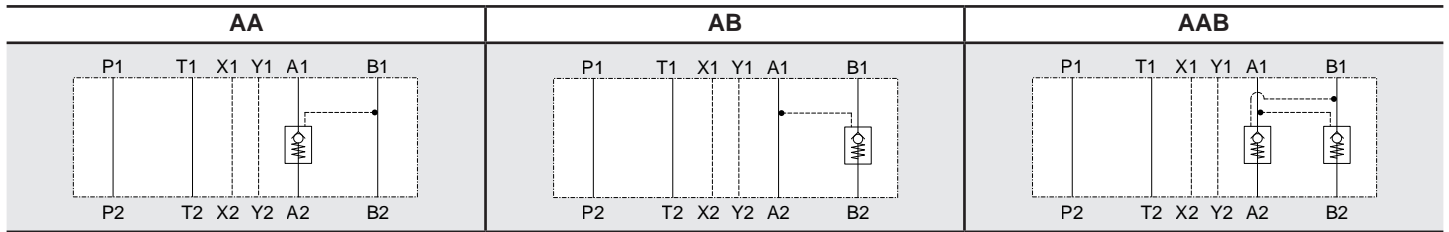

SECTION VIEW

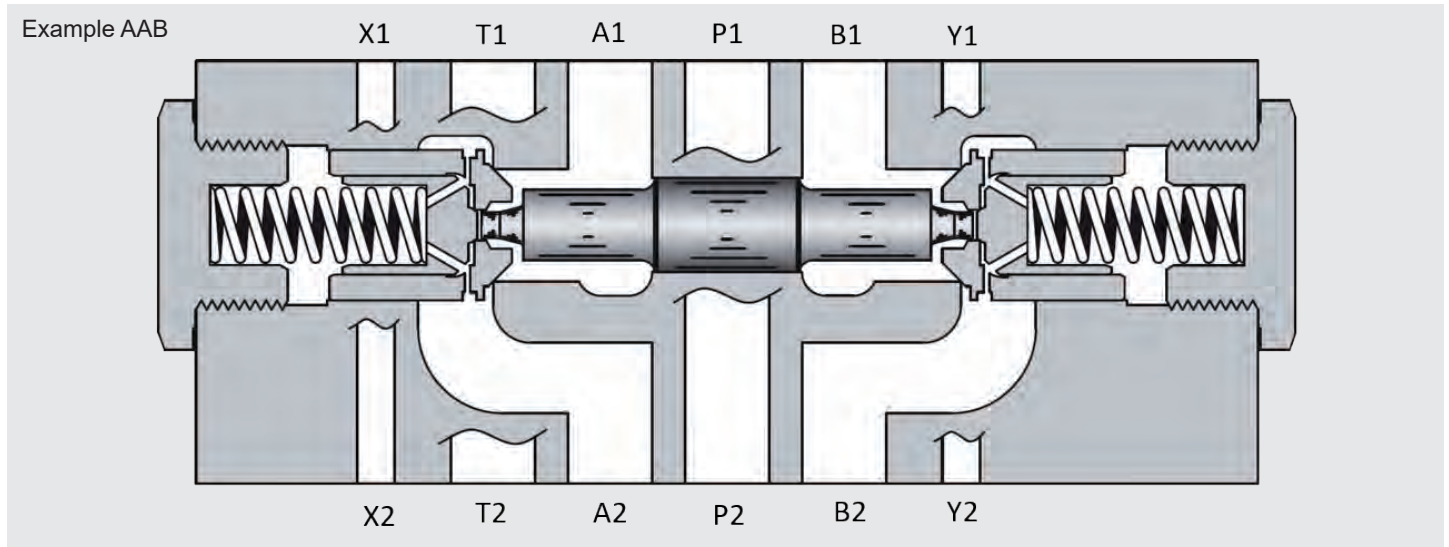

FUNCTION

The check valve, pilot-to-open in sandwich plate design in nominal size 25 is a direct-acting, spring-loaded poppet valve. It releases flow from the directional valve to the consumer and blocks flow from the consumer to the directional valve. To achieve this, the valve poppet is pressed into the seat and blocks the flow. If sufficiently high pilot pressure is built up in the relevant pilot port, the valve is unblocked and flow flows from the consumer to the directional valve. The required pilot pressure is based on the pressure difference between the ports to be unblocked.

Hint

The casings have O-ring seals at the ports on the plate side.

A pressure in the port of the directional valve influences the required control pressure.

PERFORMANCE

Measured at $v = 35 \text{ mm}^2/\text{s}$ and $T_{\text{oil}} = 45 \text{ }^\circ\text{C}$

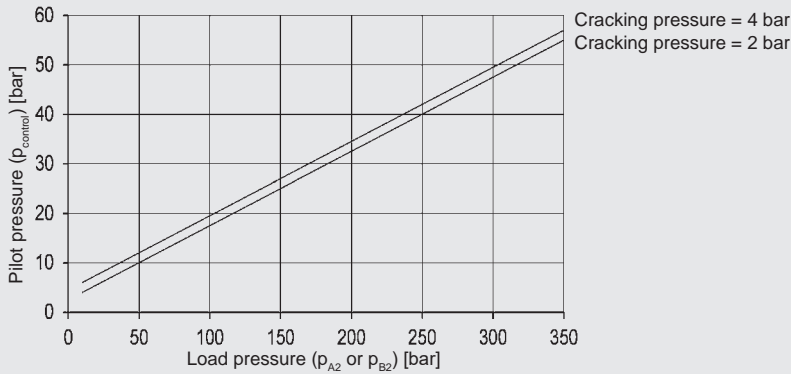
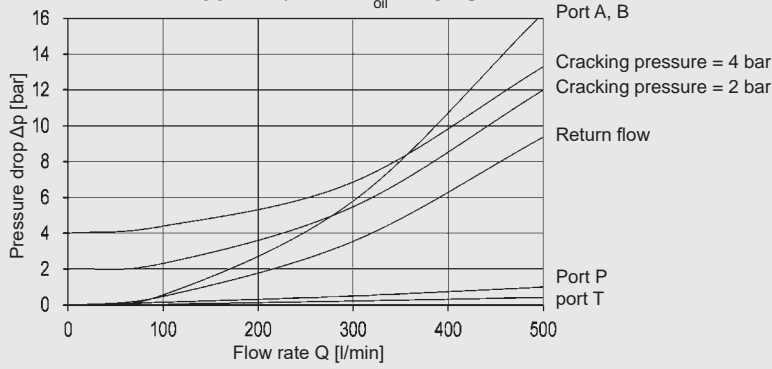

Use the following formula to calculate the min. required pilot pressure in port B:

$$p_{\text{control}} = \frac{p_{A2} - p_{A1}}{\varphi} + p_{A1}$$

Use the following formula to calculate the min. required pilot pressure in port A:

$$p_{\text{control}} = \frac{p_{B2} - p_{B1}}{\varphi} + p_{B1}$$

DIMENSIONS

Interface according to ISO 4401-08-08-0-05 (Cetop 8)

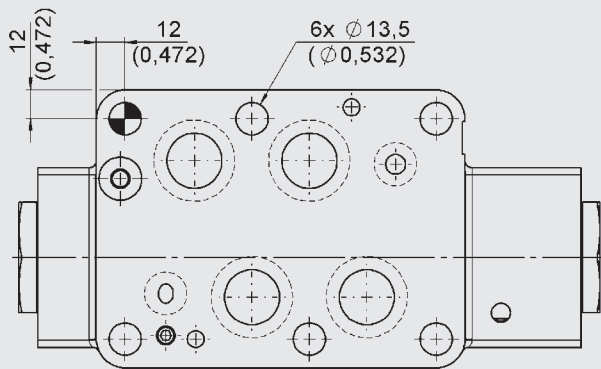
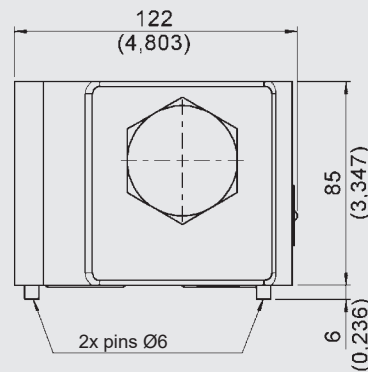
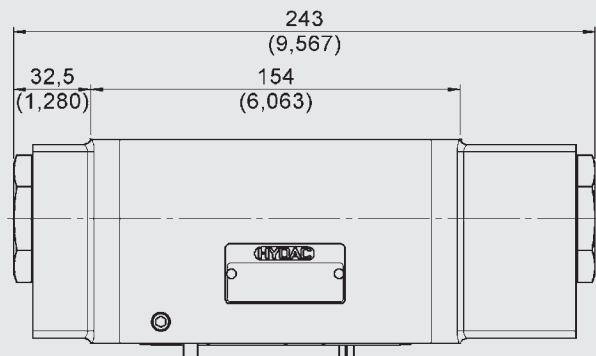
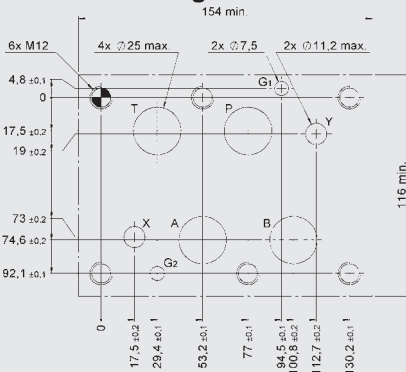

ACCESSORIES

	Designation	Part no.
Seal kits (6-part set)	29.82 x 2.62 -NBR -90 Sh (4 pieces)	3524659
	20.24 x 2.62 -NBR -90 Sh (2 pieces)	
	29.82 x 2.62 -FKM -90 Sh (4 pieces)	3524660
	20.24 x 2.62 -FKM -90 Sh (2 pieces)	

Note

The information in this brochure relates to the operating conditions and applications described.
For applications or operating conditions not described, please contact the relevant technical department.
Subject to technical modifications.

HYDAC Fluidtechnik GmbH
Justus-von-Liebig-Str.
66280 Sulzbach / Saar
Tel.: 06897 / 509 -01
Fax: 06897 / 509 -598
E-mail: valves@hydac.com

Proportional directional valve direct-acting P4WE 6

DESCRIPTION

HYDAC 4/3 proportional directional valves of the P4WE series combines directional control with speed control of the consumer.

The controlled volume flow is proportional to the electrical input signal on the solenoid.

FEATURES

- High nominal flow due to optimized, cast casing
- Low hysteresis due to precision machining of moving parts
- Easy interchangeability due to internationally standardised interface ISO 4401
- Electronic control by EHCD (see brochure 2.429.2)

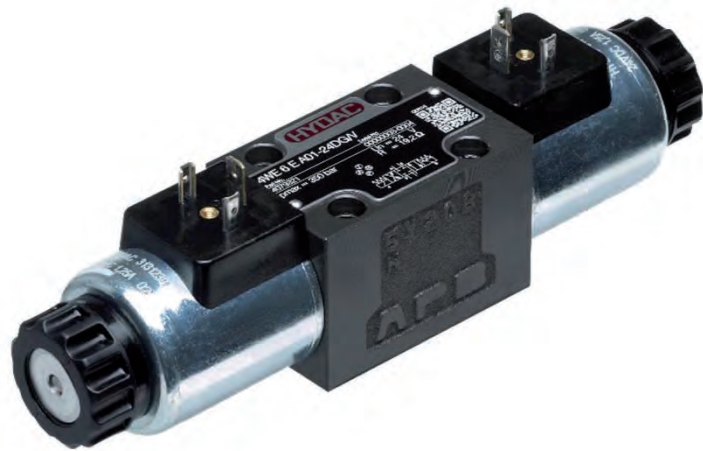

Nominal size 6
up to 40 l/min
up to 350 bar

CONTENT

Description

Features

Model code

Spool types / Symbols

Technical Data

Function

Section view

Performance

Dimensions

Accessories

MODEL CODE

P4WE 6 E 16 A01 – 24 PG /V

Type

Proportional directional valve

Nominal size (NG)

6

Symbol

see chapter „Spool types / Symbols“

Nominal flow (bei $\Delta p = 10 \text{ bar}$, $P \rightarrow T$)

04 = 4 l/min

08 = 8 l/min

16 = 16 l/min

26 = 26 l/min

Series

A01 = specified by the manufacturer

Rated voltage of the solenoid coil

12 = 12 VDC

24 = 24 VDC

Coil type

PG = device connector to DIN EN175301-803

PN = device connector , Deutsch

Sealing material

V = FKM (standard)

N = NBR

SPOOL TYPES / SYMBOLS

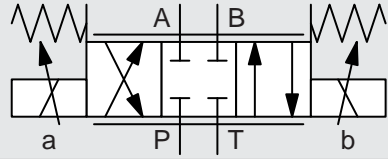
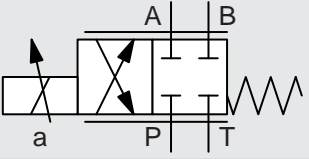
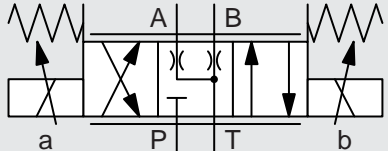
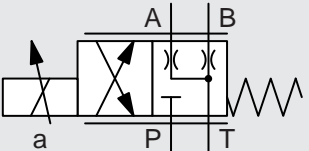
Type	Basic symbol	Type	Basic symbol
E		EA	
Q		QA	

FUNCTION

The proportional valves of the P4WE series are direct-acting valves. The volume flow is controlled continuously (proportionally) to the electrical input signal at the solenoid coil. The valve consists of a valve casing (1), a control piston (2) and two proportional solenoids (3).

According to the input signal, the solenoid generates a force and shifts the piston against a spring. This releases cross-sections, which define the size of the volume flow, depending on the pressure difference at the relevant control element.

For electrical control of the coil there are electronic controls available (see brochure 5.249.2).

1. Hint:

Vent system and valve before setting in motion.

2. Hint:

The valves are available in 12V and 24V coil versions. A 24VDC supplied control electronics enables improved dynamic and hysteresis values for a valve with 12V coil. A control electronic supplied with 12VDC can only be used in combination with a 12V coil version. Then the dynamic advantage of the valve is lost.

SECTION VIEW

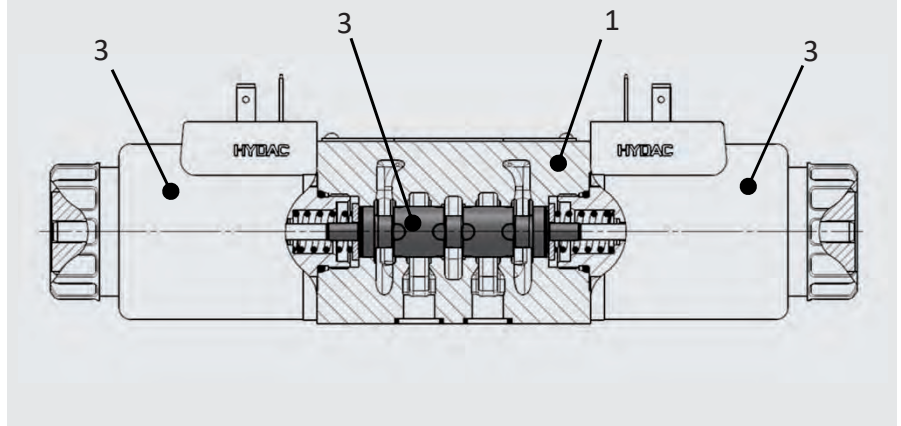

TECHNICAL DATA ¹

General specifications

MTTF _d :	To EN ISO 13849-1:2015 Tabelle C1 & C2	
Ambient temperature:	[°C]	-20 to +60
Installation position:	No orientation restrictions	
Weight:	[kg]	1,5 one solenoid; 2,0 two solenoids
Material:	Valve casing :	Cast iron
	Name plate:	Aluminium
Surface coating:	Valve casing:	Phosphate

Hydraulic specifications

Operating pressure:	[bar]	Port P, A, B:	$p_{max} = 350$
		Port T:	$p_{max} = 210$
max. flow (Q_{max}):	[l/min]	see chapter „Performance“	
Operating fluid:	Hydraulic oil to DIN 51524 part 1, 2 and 3		
Media operating temperature range:	[°C]	-20 to +80	
Viscosity range:	[mm ² /s]	10 – 400	
Permitted contamination level of operating fluid:	class 18/16/13 to ISO 4406		
Sealing material:	NBR, FKM (standard)		

Electrical specifications

Switching time:	[ms]	energized:	approx. 50 - 100
	[ms]	de-energized:	approx. 10 - 60
Type of voltage:	DC		
Rated voltage:	[V]	12, 24	
Nominal current:	[A]	2,25 at 12 VDC 1,60 at 24 VDC	
Resistance at 20°C:	[Ω]	2,7 at 12 VDC 5,0 at 24 VDC	
Average hysteresis:	[%]	6,0 of Q_{max}	
Average repeatability :	[%]	$\pm 1,5$ of Q_{max}	
Protection class to DIN EN 60529:	with electrical connection "G" "IP65" ² with electrical connection "N" "IP65" ²		

¹ see „Conditions and Instructions for Valves“ in brochure 53.000

² if installed correctly

PERFORMANCE

measured at $T_{oil} = 42^{\circ}\text{C}$ and $36 \text{ mm}^2/\text{s}$, 24 V

The performance curves represent typical flow curves for different valve pistons. The first curve shows the flow value at constant Δp , depending on the solenoid current. The second curve describes the dependency of flow value and Δp at constant solenoid current.

The total valve pressure drop (Δp) was measured between port P and T of the valve.

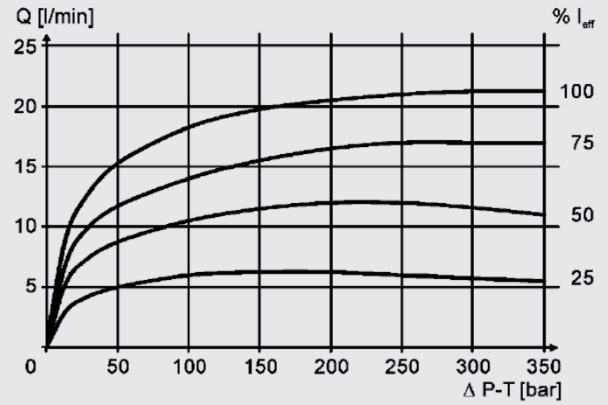

E 04 spool

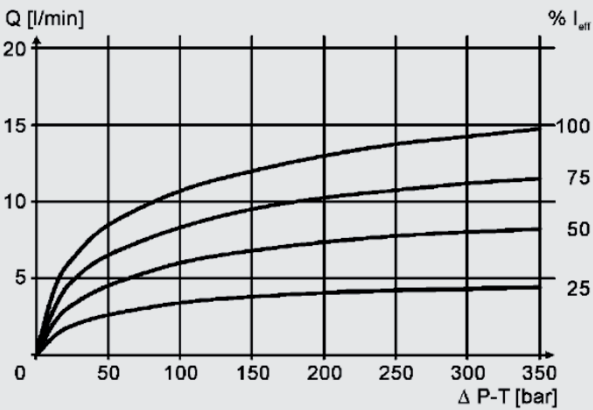
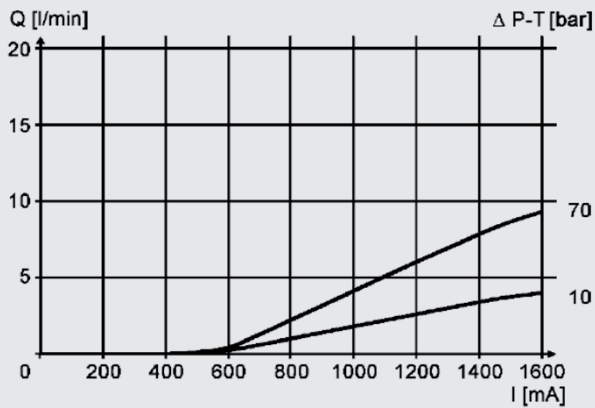

E 16 spool

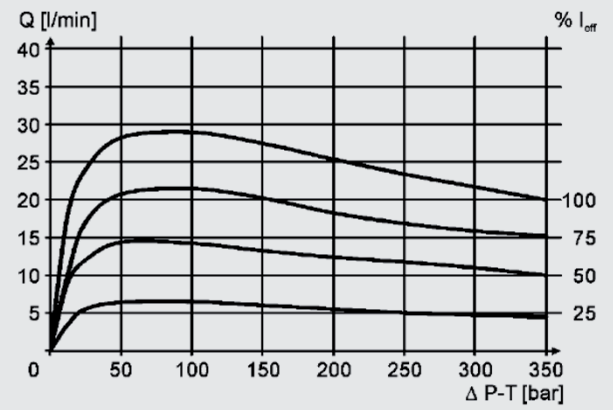
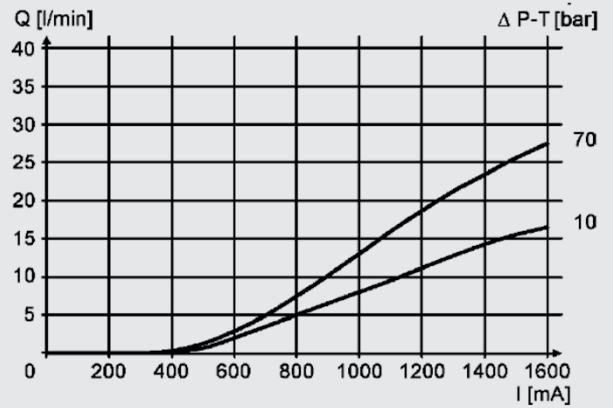

E 08 spool

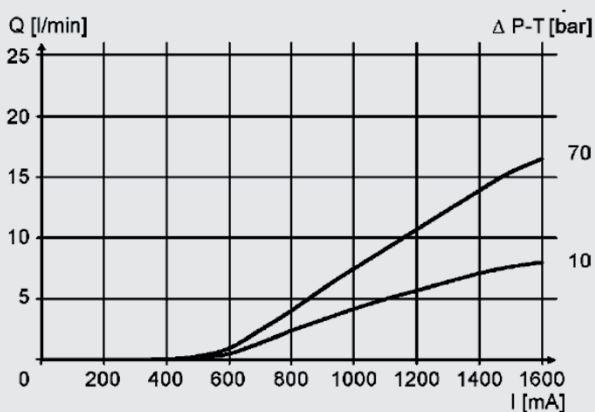

E 26 spool

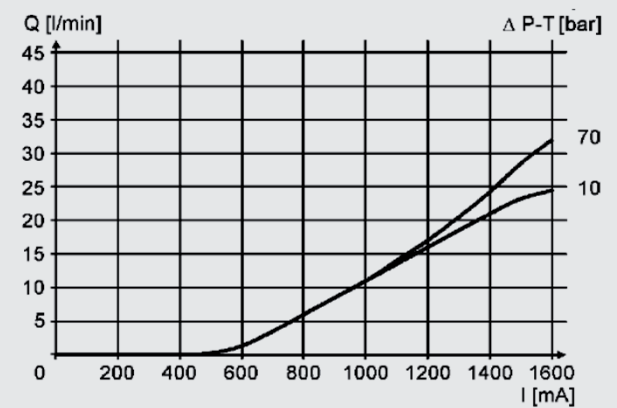

PERFORMANCE

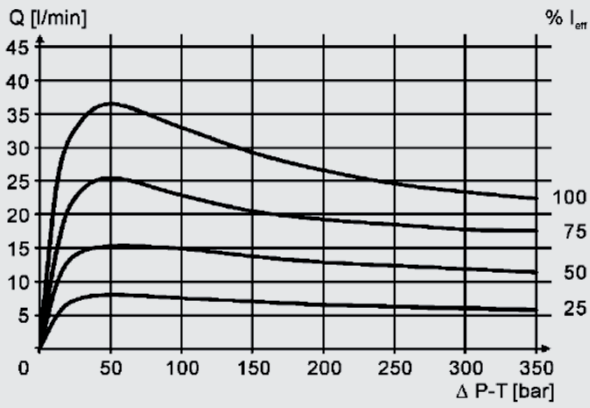

Q 04 spool

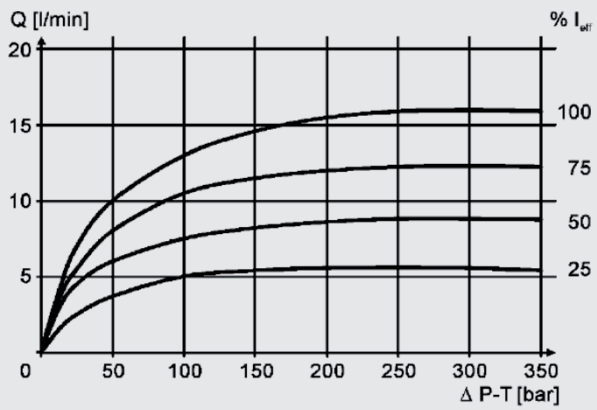
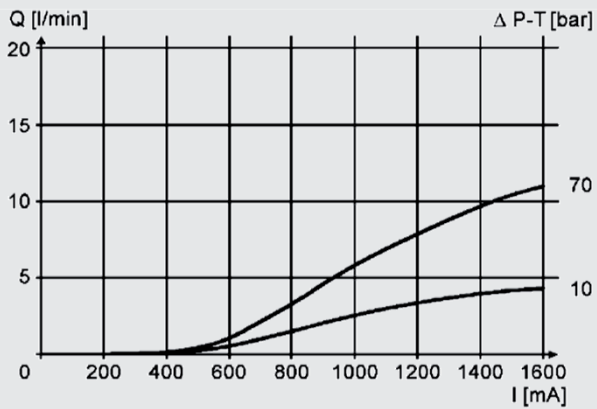

Q 08 spool

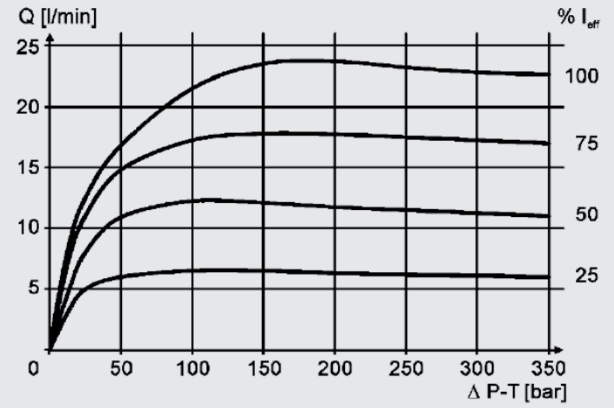
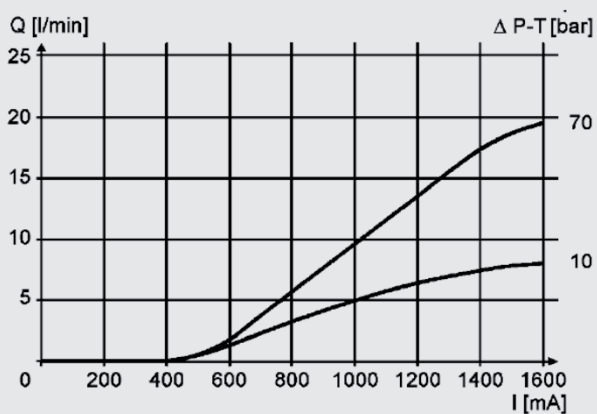

Q 16 spool

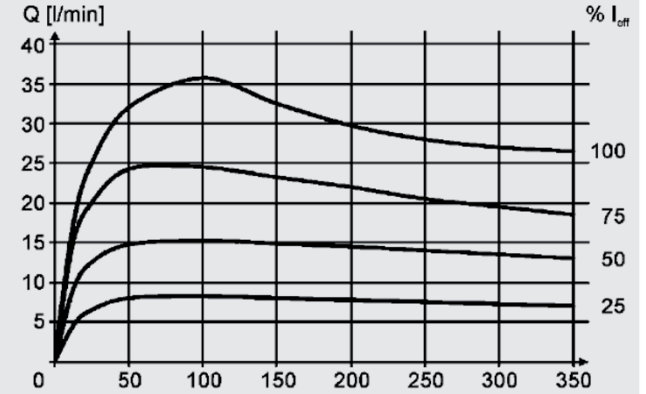
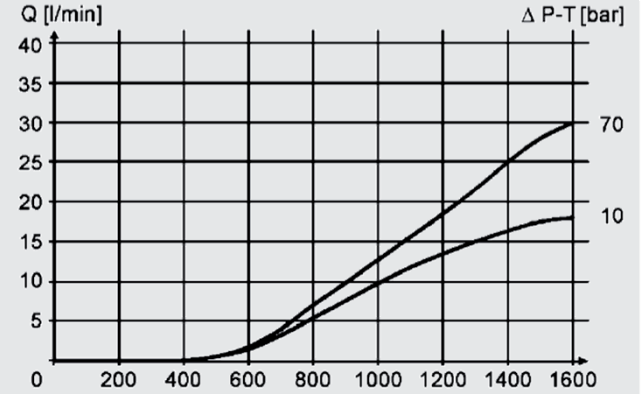

Q 26 spool

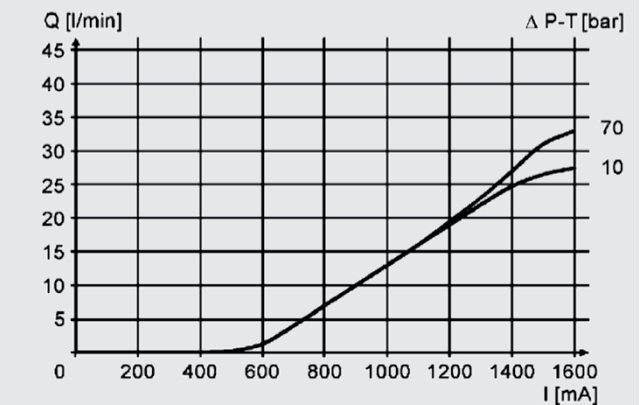

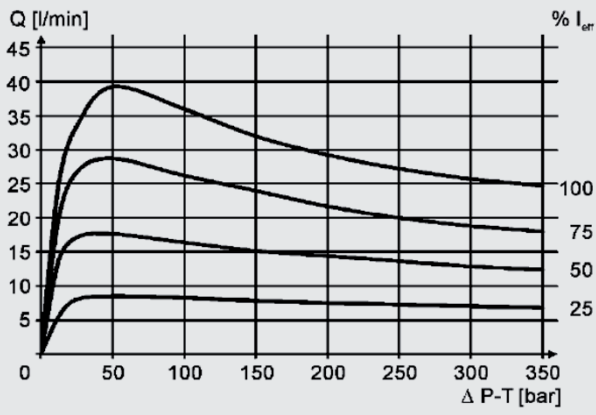

DIMENSIONS

INTERFACE

ISO 4401-03-02-0-05 (Cetop 3)

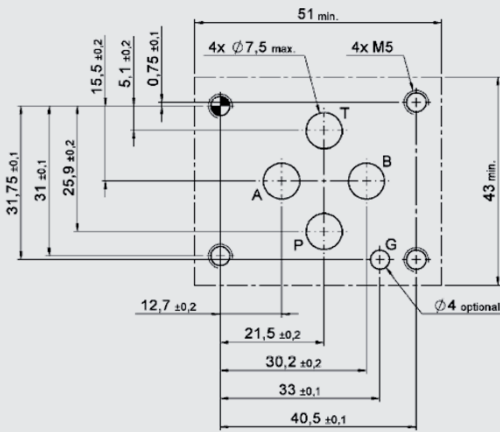

clamping length

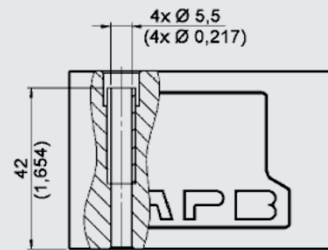

With two solenoids

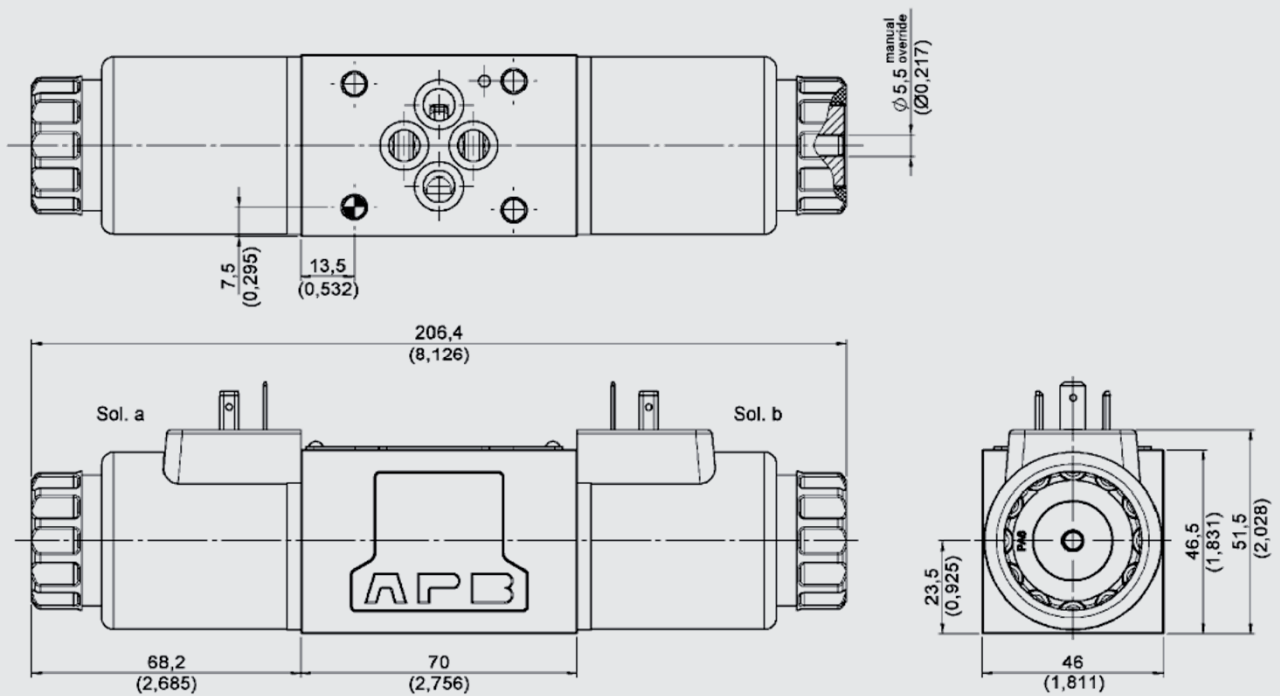

With one solenoid

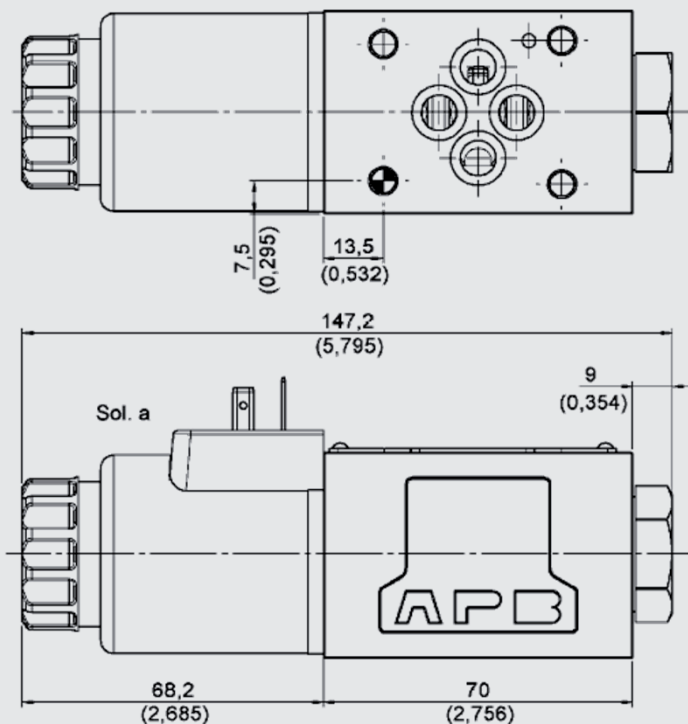

Mounting screws:

(not included in delivery)
 DIN EN ISO 4762 - M5 x 50 - 10.9
 Torque: 7 Nm

Note

The information in this brochure relates to the operating conditions and applications described. For applications not described, please contact the relevant technical department. All technical details are subject to change without notice.

ACCESSORIES

	Designation	Part no.
Seal kits (4-part set)	9,25 x 1,78 90 Sh FKM	3120269
	9,25 x 1,78 90 Sh NBR	3492432
Mounting screws	ISO 4762 M5 x 50 – 10.9 (4 pcs)	4312231
Solenoids coils	COIL 12PG- 2.7 -50-2345 -S	4356846
	COIL 12PN- 2.7 -50-2345 -S	4356849
	COIL 24PG- 5 -50-2345 -S	4356848
	COIL 24PN- 5 -50-2345 -S	4356851
Seal kit for solenoid coil	Mutter offen, O-Ring	4317299
Connector	Z4 Standard 2-polig ohne PE	394287
	ZW4 inkl. Brückengleichrichter	394293
	Z4L inkl. LED	394285
Control module EHCD*	AM005XXXU	6158999

* For further information see brochure "Control modules for hydraulic drives -EHCD" catalogue-24000.2/10/14 or contact customer support EHCD@hydac.com.

HYDAC Fluidtechnik GmbH
 Justus-von-Liebig-Str.
D-66280 Sulzbach/Saar
 Tel: 0 68 97 /509-01
 Fax: 0 68 97 /509-598
 E-Mail: valves@hydac.com

4/3 proportional directional valve direct-acting P4WE 10

DESCRIPTION

HYDAC 4/3 proportional directional valves of the P4WE series combines directional control with speed control of the consumer.

The controlled volume flow is proportional to the electrical input signal on the solenoid.

FEATURES

- High nominal flow due to optimized, cast casing
- Low hysteresis due to precision machining of moving parts
- Easy interchangeability due to internationally standardised interface ISO 4401
- Electronic control by EHCD (see brochure 2.429.2)

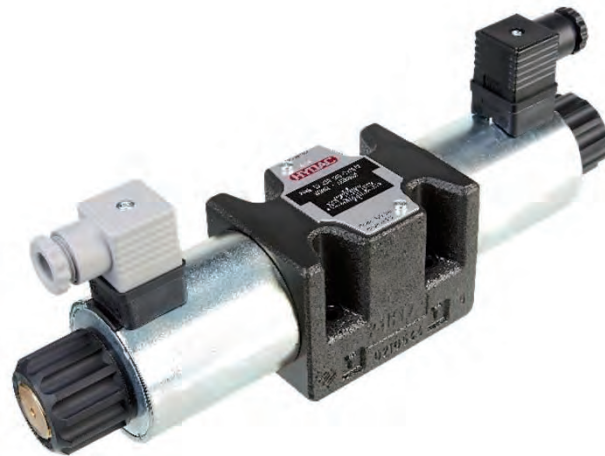

Nominal size 10
up to 90 l/min
up to 320 bar

CONTENT

Description

Features

Model code

Spool types / Symbols

Technical Data

Function

Section view

Accessories

Performance

Dimensions

MODEL CODE

P4WE 10 E 30 D01 – 24 PG /V

Type

Proportional directional valve

Nominal size (NG)

10

Symbol

see chapter „Spool types / Symbols“

Nominal flow (at $\Delta p = 10$ bar, $P \rightarrow T$)

30 = 30 l/min

60 = 60 l/min

Series

D01 = standard with manual override

Rated voltage of the solenoid coil

12 = 12 VDC

24 = 24 VDC

Coil type

PG = DIN connector to EN175301-803

Sealing material

V = FKM (Standard)

N = NBR

SPOOL TYPES / SYMBOLS

Type	Basic symbol	Type	Basic symbol
E		Q	

FUNCTION

The proportional valves of the P4WE series are direct-acting valves. The volume flow is controlled continuously (proportionally) to the electrical input signal at the solenoid coil. The valve consists of a valve casing (1), a control piston (2) and two proportional solenoids (3).

According to the input signal, the solenoid generates a force and shifts the piston against a spring. This releases cross-sections, which define the size of the volume flow, depending on the pressure difference at the relevant control element.

For electrical control of the coil there are electronic controls available (see brochure 5.249.2).

1. Hint:

Vent system and valve before setting in motion.

2. Hint:

The valves are available in 12V and 24V coil versions. A 24VDC supplied control electronics enables improved dynamic and hysteresis values for a valve with 12V coil. A control electronic supplied with 12VDC can only be used in combination with a 12V coil version. Then the dynamic advantage of the valve is lost.

SECTION VIEW

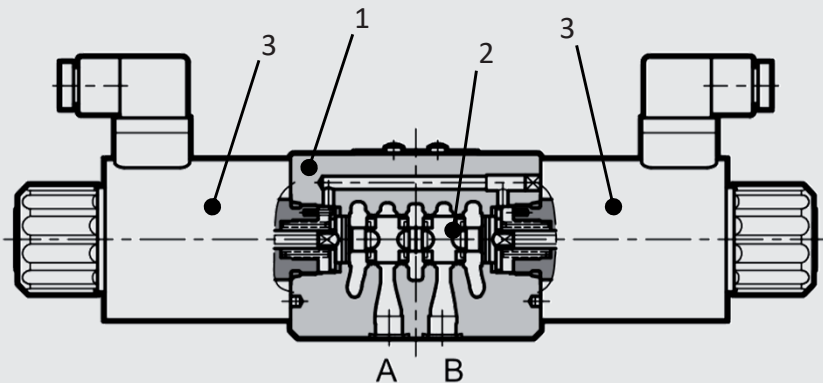

ACCESSORIES

	Designation	Part no.
Seal kits (4-part set)	12,45 x 1,78 90 Sh FKM 12,45 x 1,78 90 Sh NBR	3524439 3524438
Mounting screws	ISO 4762 M6 x 40 (4 pcs)	3524314
Control module EHCD*	AM005XXXU	6158999

*For further information see brochure "Control modules for hydraulic drives -EHCD" catalogue-24000.2/10/14 or contact customer support EHCD@hydac.com.

TECHNICAL DATA ¹

General specifications		
MTTF _d :	To EN ISO 13849-1:2015 Tabelle C1 & C2	
Ambient temperature:	[°C]	-20 to +60
Installation position:	No orientation restrictions	
Weight:	[kg]	5,9
Material:	Valve casing :	Cast iron
	Name plate:	Aluminium
Surface coating:	Valve casing:	Phosphate
Hydraulic specifications		
Operating pressure:	[bar]	Port P, A, B: p _{max} = 320 Port T: p _{max} = 210
max. flow: (Δp = 10 bar, P→T)	[l/min]	90
Operating fluid:	Hydraulic oil to DIN 51524 part 1, 2 and 3	
Media operating temperature range:	[°C]	-20 to +80
Viscosity range:	[mm ² /s]	10 – 400
Permitted contamination level of operating fluid:	class 18/16/13 to ISO 4406	
Sealing material:	NBR, FKM (standard)	
Electrical specifications		
Switching time (0 → 100%):	[ms]	50
Switching time (100% → 0):	[ms]	40
Type of voltage:	DC	
Rated voltage:	[V]	12, 24
Nominal current:	[A]	2,60 at 12 VDC 1,60 at 24 VDC
Resistance at 20°C:	[Ω]	3,40 at 12 VDC 8,65 at 24 VDC
Hysteresis:	[%]	< 6,0 of Q _{max}
Repeatability:	[%]	< ±1,5 of Q _{max}
Protection class to DIN EN 60529:	with electrical connection "G" IP65 ²	

¹ see „Conditions and Instructions for Valves“ in brochure 53.000

² if installed correctly

PERFORMANCE

measured at $T_{oil} = 50^{\circ}\text{C}$ and $36 \text{ mm}^2/\text{s}$

The performance curves represent typical flow curves for different valve pistons. The first curve shows the flow value at constant Δp , depending on the solenoid current. The second curve describes the dependency of flow value and Δp at constant solenoid current. The total valve pressure drop (Δp) was measured between port P and T of the valve.

E 30 spool

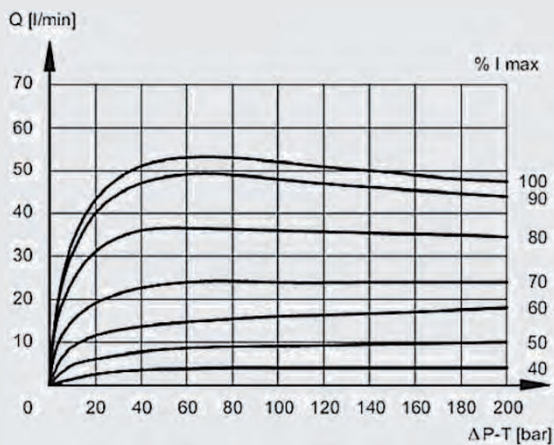
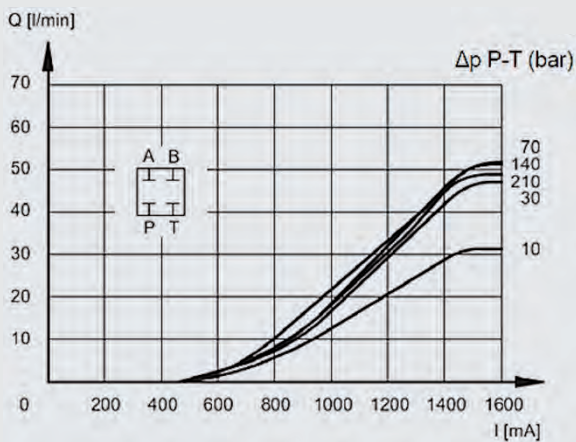

E 60 spool

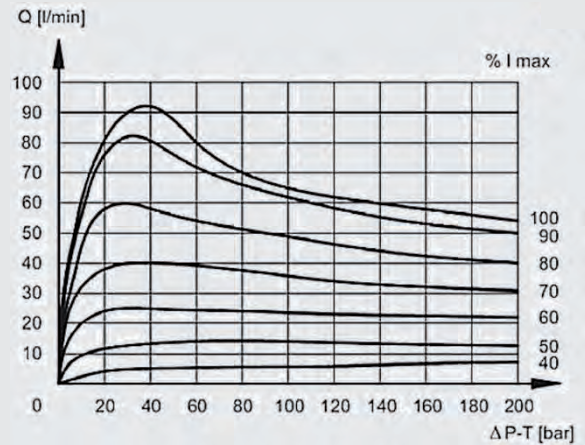
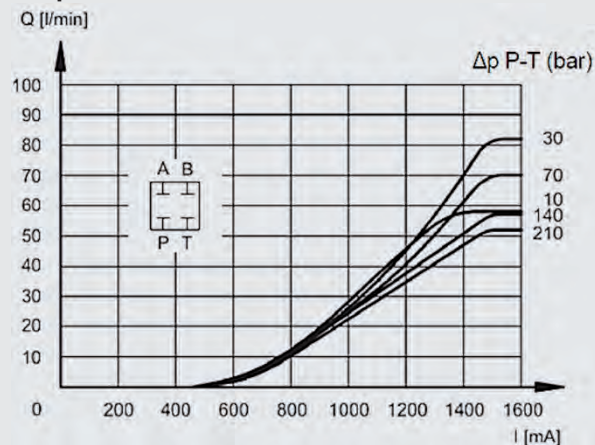

Q 30 spool

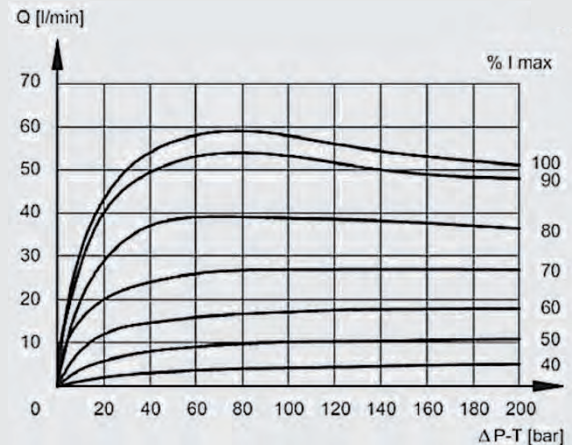
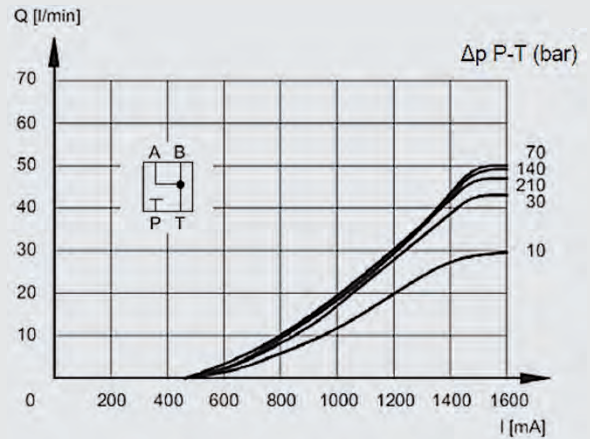

Q 60 spool

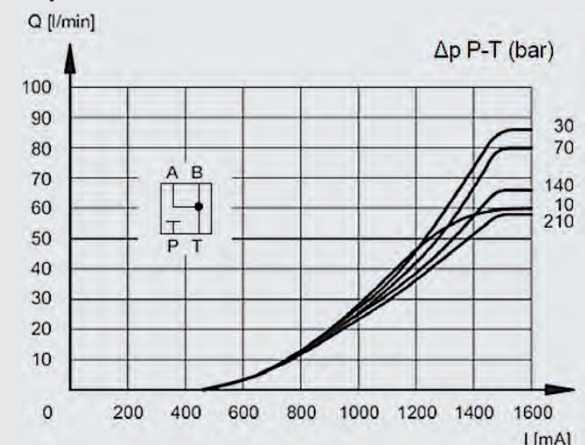

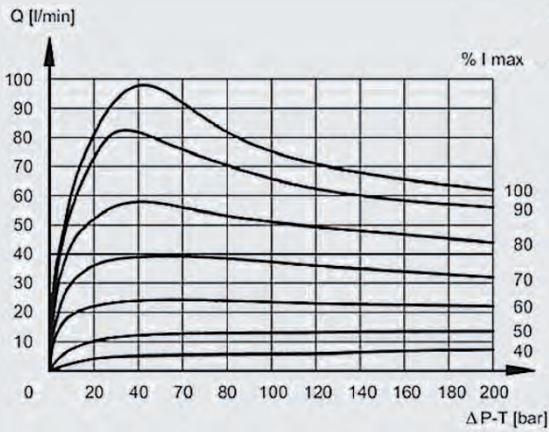

DIMENSIONS

INTERFACE

ISO 4401-05-04-0-05

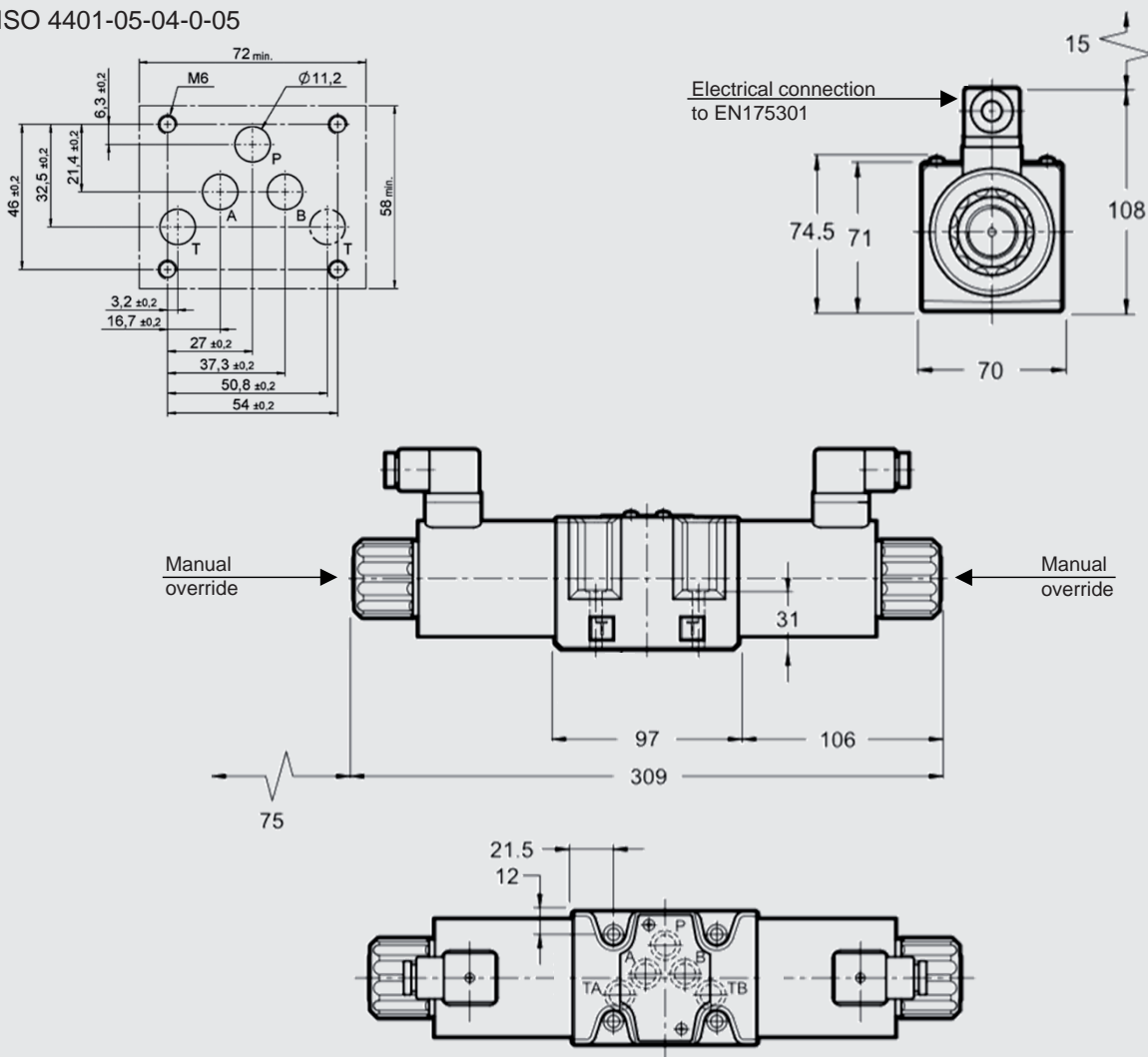

Mounting screws (ISO 4762): 4 pcs M6 x 40 A10.9 (not included in delivery)
Torque: 8 Nm

Note

The information in this brochure relates to the operating conditions and applications described. For applications not described, please contact the relevant technical department.
All technical details are subject to change without notice.

HYDAC Fluidtechnik GmbH
Justus-von-Liebig-Str.
D-66280 Sulzbach/Saar
Tel: 0 68 97 /509-01
Fax: 0 68 97 /509-598
E-Mail: valves@hydac.com

4/3 proportional directional valve direct-acting with transducer P4WER 06

DESCRIPTION

HYDAC proportional valves of the P4WER series combines directional control with speed control of the consumer.

The controlled volume flow is proportional to the electrical input signal on the valve electronics.

FEATURES

- High nominal flow due to optimized, cast casing
- Low hysteresis due to precision machining of moving parts
- Easy interchangeability due to internationally standardised interface ISO 4401
- With integrated transducer
- Electronic control by EHCD (see brochure 2.429.2)



Nominal size 6
up to 40 l/min
up to 350 bar

CONTENT

Description

Features

Model code

Spool types / Symbols

Technical Data

Function

Section view

Accessories

Performance

Transducer

Dimensions

MODEL CODE

P4WER 06 E 16 D01 – 24 PG /V

Type

Proportional directional valve with integrated transducer

Nominal size (NG)

6

Symbol

see chapter „Spool types / Symbols“

Nominal flow (at $\Delta p = 10 \text{ bar}$, $P \rightarrow T$)

08 = 8 l/min

16 = 16 l/min

26 = 26 l/min

Series

D01 = standard with manual override

Rated voltage of the solenoid coil

12 = 12 VDC

Coil type

PG = DIN connector to EN175301-803

Sealing material

V = FKM (standard)

N = NBR

SPOOL TYPES / SYMBOLS

Type	Basic symbol	Type	Basic symbol
E		Q	

FUNCTION

The proportional valves of the P4WER series are direct-acting valves with integrated transducer.

The volume flow is controlled continuously (proportionally) to the electrical input signal at the solenoid coil. The valve consists of a valve casing (1), a control piston (2), as well as the transducer (4) and two proportional solenoids (3).

According to the input signal, the solenoid generates a force and shifts the piston against a spring. This releases cross-sections, which define the size of the volume flow, depending on the pressure difference at the relevant control element.

For electronic control of the coil there are electronic controls available (see brochure 2.429.2).

1. Hint:

Vent system and valve before setting in motion.

2. Hint:

The valve is only available in 12V coil version. A 24VDC powered control electronics supplies the transducer and enables improved dynamic values.

SECTION VIEW

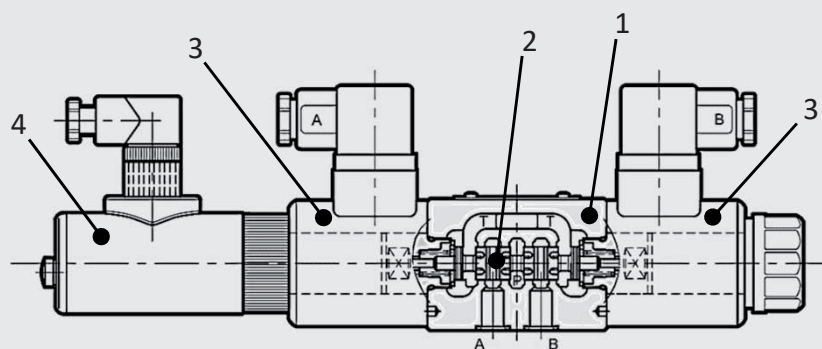

ACCESSORIES

	Designation	Part no.
Seal kits (4-part set)	9,25 x 1,78 90 Sh FKM	3524413
	9,25 x 1,78 90 Sh NBR	3524355
Mounting screws (4-part set)	ISO 4762 M5 x 30	3524313
Control module EHCD*	AM005XXXU	6158999

*For further information see brochure "Control modules for hydraulic drives -EHCD" catalogue-24000.2/10/14 or contact customer support EHCD@hydac.com.

TECHNICAL DATA ¹

General specifications			
MTTF _d :		To EN ISO 13849-1:2015 chart C1 & C2	
Ambient temperature:	[°C]	-20 to +60	
Installation position:		No orientation restrictions	
Weight:	[kg]	2,3	
Material:	Valve casing:	Cast iron	
	Name plate:	Aluminium	
Surface coating:	Valve casing:	Phosphate	
Hydraulic specifications			
Operating pressure:	[bar]	Port P, A, B:	p _{max} = 350
		Port T:	p _{max} = 210
max. flow: (Δp = 10 bar, P→T)	[l/min]	40	
Operating fluid:		Hydraulic oil to DIN 51524 part 1, 2 and 3	
Media operating temperature range:	[°C]	-20 to +80	
Viscosity range:	[mm ² /s]	10 – 400	
Permitted contamination level of operating fluid:		class 18/16/13 to ISO 4406	
Sealing material:		NBR, FKM (standard)	
Electrical specifications			
Switching time (0 → 100%):	[ms]	30	
Switching time (100% → 0):	[ms]	25	
Type of voltage:		DC	
Rated voltage:	[V]	12	
Nominal current:	[A]	1,88 at 12 VDC	
Resistance at 20°C:	[Ω]	3,66 at 12 VDC	
Hysteresis:	[%]	< 1,5 of Q _{max}	
Repeatability:	[%]	< ±1,0 of Q _{max}	
Protection class to DIN EN 60529:		with electrical connection "G" IP65 ²	

¹ see „Conditions and Instructions for Valves“ in brochure 53.000

² if installed correctly

PERFORMANCE

measured at $T_{oil} = 50^{\circ}C$ and $36 \text{ mm}^2/s$

The performance curves represent typical flow curves for different valve pistons. The first curve shows the flow value at constant Δp , depending on the solenoid current. The second curve describes the dependency of flow value and Δp at constant solenoid current. The total valve pressure drop (Δp) was measured between port P and T of the valve.

E 08 spool

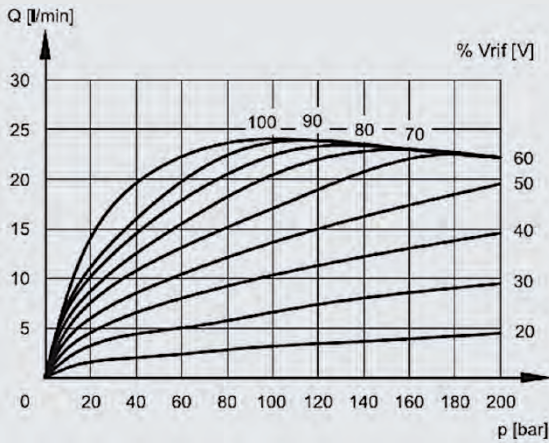
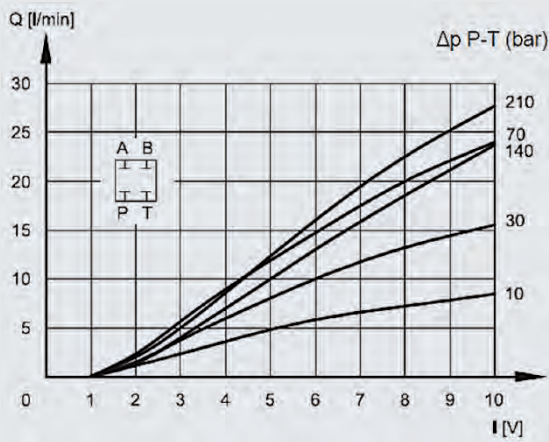

E 16 spool

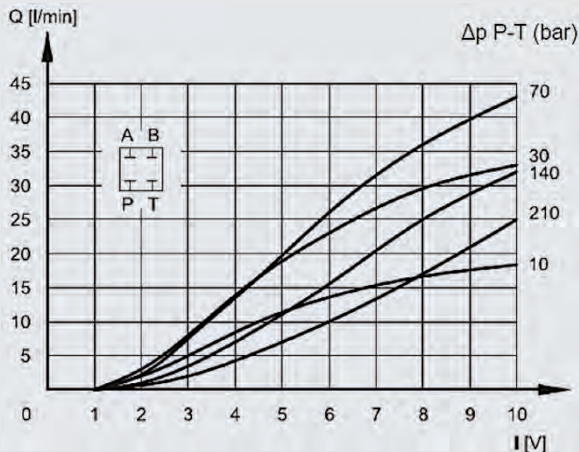

E 26 spool

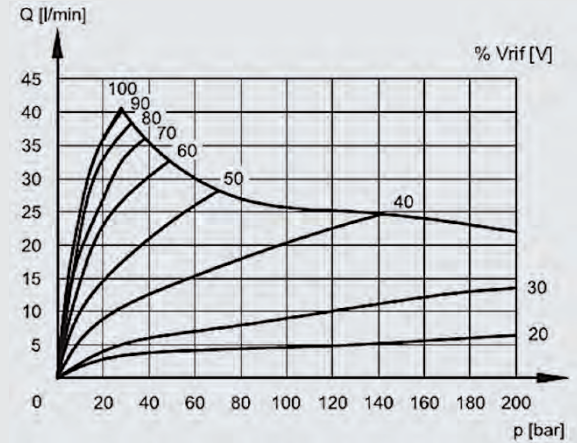
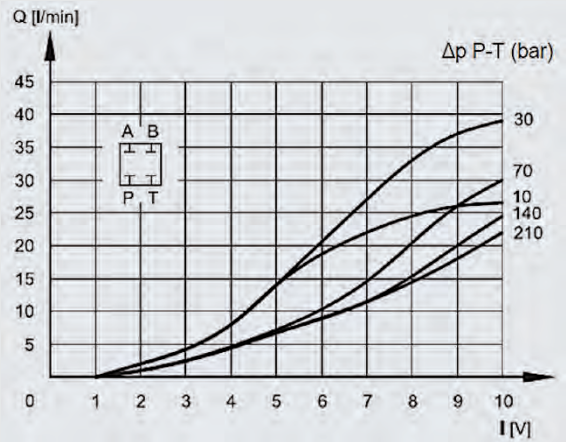

Q 08 spool

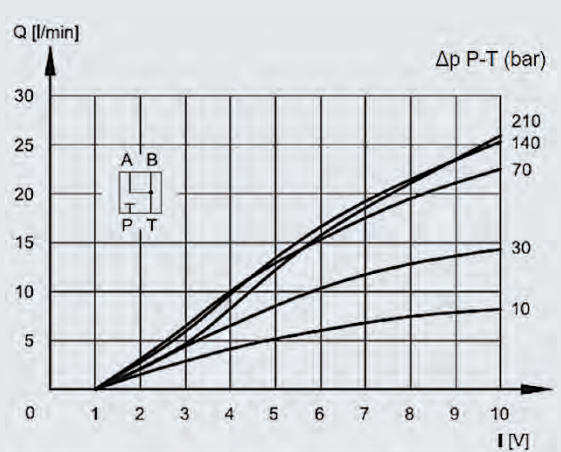

PERFORMANCE

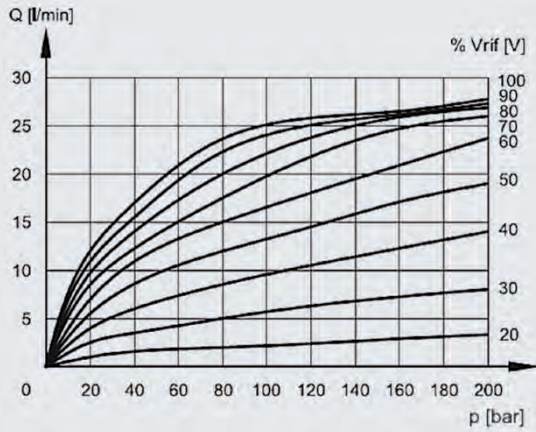

Q 16 spool

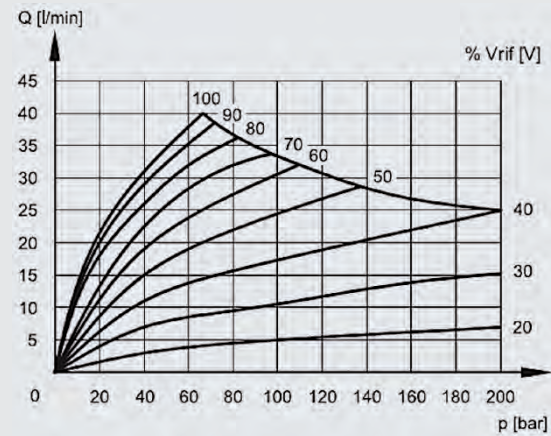
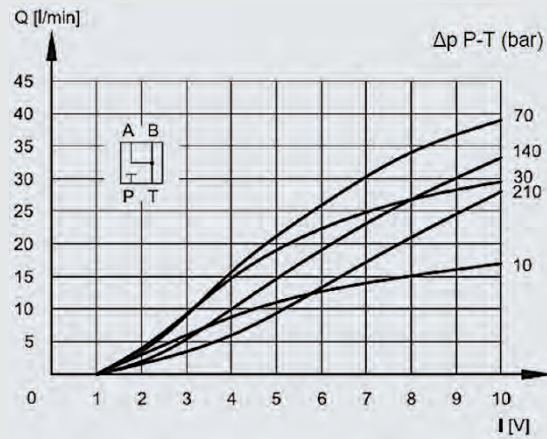

Q 26 spool

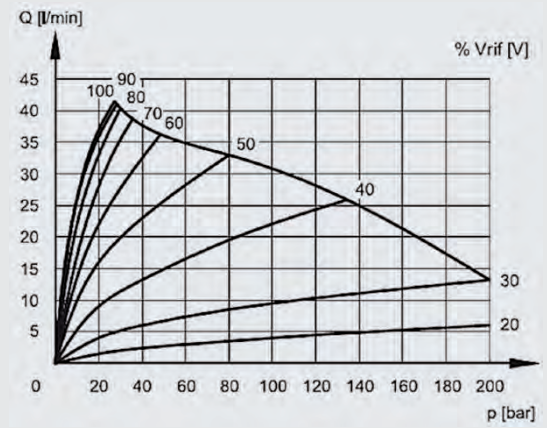
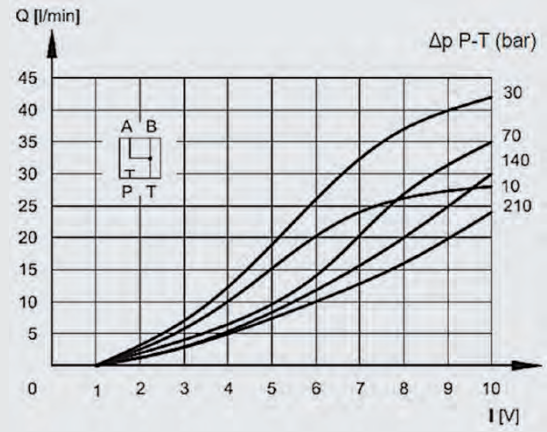

TRANSDUCER

position transducer – electrical connection

Pin 1 | supply 18 ÷ 36 V
 Pin 2 | output 2 ÷ 10 V
 Pin 3 | 0 V
 Pin 4 | NC

Pin 8c
 Pin 24a
 Pin 22c
 NC

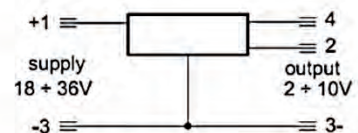
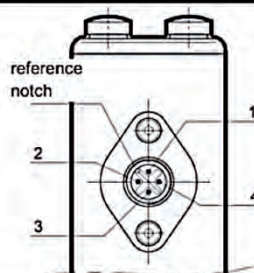

DIMENSIONS

INTERFACE

ISO 4401-03-02-0-05

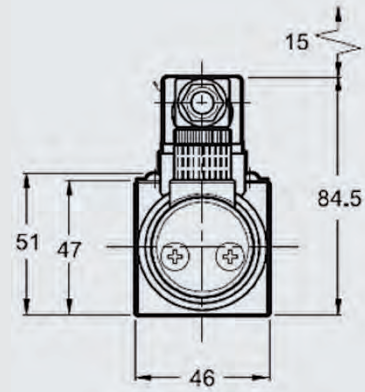
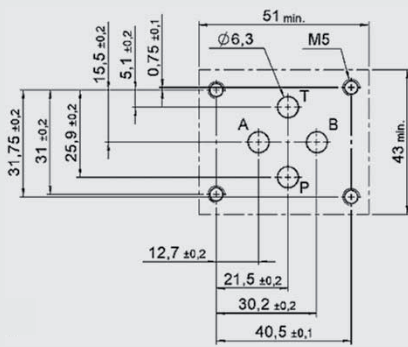

Electrical
connection
4 pole
(EC4S/M12S/10)

Connector to
EN175301-803

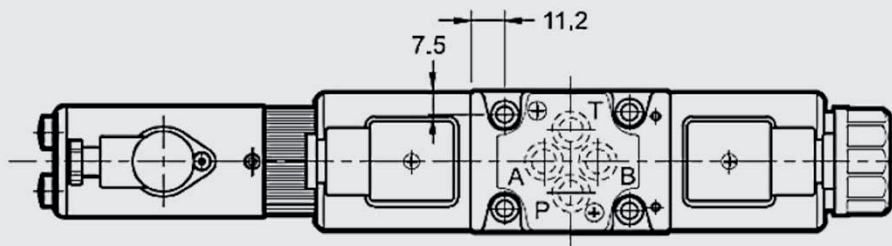
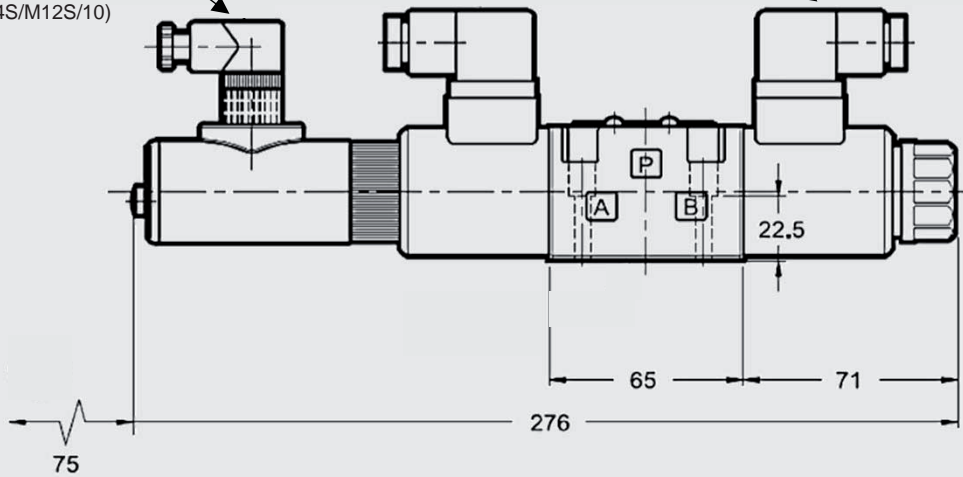

Mounting screws (ISO 4762): 4 pcs M5 x 30 A10.9 (not included in delivery)
Torque: 5 Nm

Note

The information in this brochure relates to the operating conditions and applications described. For applications not described, please contact the relevant technical department.
All technical details are subject to change without notice.

HYDAC Fluidtechnik GmbH
Justus-von-Liebig-Str.
D-66280 Sulzbach/Saar
Tel: 0 68 97 /509-01
Fax: 0 68 97 /509-598
E-Mail: valves@hydac.com

4/3 proportional directional valves direct-acting with Onboard Electronic P4WEE 06

DESCRIPTION

HYDAC proportional valves of the P4WEE series are pilot stages for pilot operated proportional directional valves with Onboard Electronic, which combines directional control with speed control of the consumer.

The controlled volume flow is proportional to the electrical input signal on the solenoid.

The integrated digital electronics allows improved performance and function due to

- shorter response times
- reduced hysteresis
- better repeatability

FEATURES

- High flow capacity due to optimized, cast casing
- Low hysteresis due to precision machining of moving parts
- Integrated digital electronics
- Easy interchangeability due to internationally standardised interface according to ISO 4401

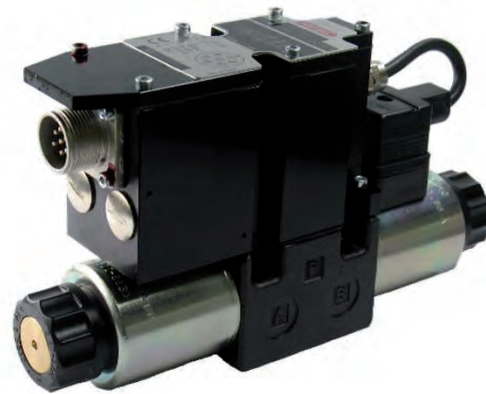

Nominal size 6
up to 40 l/min
up to 350 bar

CONTENT

Description

Features

Model code

Spool types / Symbols

Technical Data

Function

Section view

Accessories

Performance

Dimensions

Electronic

MODEL CODE

P4WEE 06 E 26 D01 – 24 PG E0 A /V

Type

Proportional directional valve
With integrated Onboard Electronic (OBE)

Nominal size (NG)

6

Symbol

see chapter „Spool types / Symbols“

Nominal flow (at $\Delta p = 10 \text{ bar}$, $P \rightarrow T$)

04 = 4 l/min

08 = 8 l/min

16 = 16 l/min

26 = 26 l/min

Series

D01 = standard with manual override

Power supply

24 = 24 VDC

Coil type

PG = DIN Stecker nach EN175301-803

Input signal

E0 = $\pm 10 \text{ V}$

E1 = 4 – 20 mA

Pin C Function

see „Diagrams Pin C Function“ in chapter „Electronic“

Sealing material

V = FKM (standard)

N = NBR

SPOOL TYPES / SYMBOLS

Type	Basic symbol	Type	Basic symbol
E		Q	
EA			

FUNCTION

The proportional valves of the P4WEE series are direct-acting valves with integrated Onboard Electronic.

The volume flow is controlled continuously (proportionally) to the electrical input signal at the solenoid coil.

The valve consists of a valve casing (1), a control piston (2) and two proportional solenoids (3).

The proportional solenoid coils are controlled via the integrated Onboard electronic (4).

According to the input signal, the solenoid generates a force and shifts the piston against a spring. This releases cross-sections P-B-A-T or P-A-B-T, which define the size of the volume flow, depending on the pressure difference at the relevant control element.

SECTION VIEW

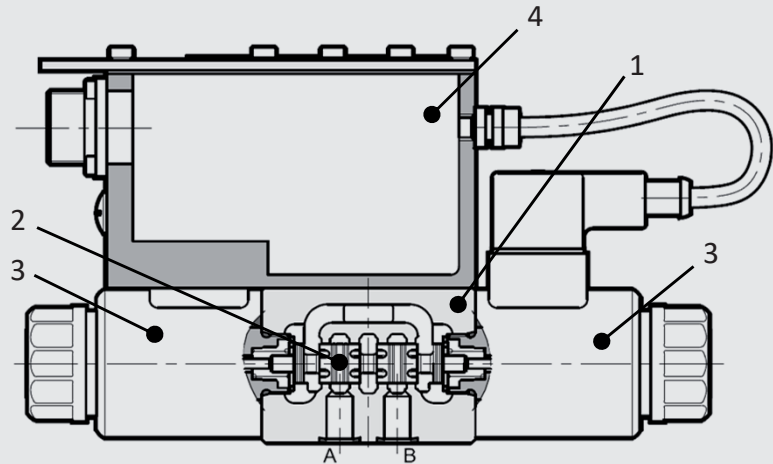

ACCESSORIES

	Designation	Part no.
Seal kits	9,25 x 1,78 90 Sh FKM	3524413
(4-part set)	9,25 x 1,78 90 Sh NBR	3524355
Mounting screws	ISO 4762 M5 x 30 (4 pcs)	3524313
Main connector	6+PE EN175201 Part 804	6080324
Electronic	Lin-Bus Interface	3648934

TECHNICAL DATA ¹

General specifications			
MTTF _d :		To EN ISO 13849-1:2015 chart C1 & C2	
Ambient temperature:	[°C]	-20 to +60	
Installation position:		No orientation restrictions	
Weight:	[kg]	2,4	
Material:		Valve casing:	Cast iron
		Name plate:	Aluminium
Surface coating:		Valve casing:	Phosphate
Hydraulic specifications			
Operating pressure:	[bar]	Port P, A, B:	p _{max} = 350
		Port T:	p _{max} = 210
Flow (Δp = 10 bar, P→T):	[l/min]	4, 8, 16, 26	
Operating fluid:		Hydraulic oil to DIN 51524 part 1, 2 and 3	
Media operating temperature range:	[°C]	-20 to +80	
Viscosity range:	[mm ² /s]	10 – 400	
Permitted contamination level of operating fluid:		class 18/16/13 to ISO 4406	
Sealing material:		NBR, FKM (Standard)	
Electrical specifications			
Switching time (0 → 100%):	[ms]	see chapter „Performance“	
Switching time (100% → 0):	[ms]	see chapter „Performance“	
Type of voltage:	[V]	DC	
Rated voltage:	[A]	24	
Nominal current of solenoid at 100% value	[mA]	800	
Hysteresis:	[%]	< 3 of Q _{max}	
Repeatability:	[%]	< ±1 of Q _{max}	
Protection class to DIN EN 60529:		with electrical connection "G" IP65 ² /IP67 ²	

¹ see „Conditions and Instructions for Valves“ in brochure 53.000

² if installed correctly

PERFORMANCE

measured at $T_{oil} = 50^{\circ}C$ and $36 \text{ mm}^2/s$

The performance curves represent typical flow curves for different valve pistons. The first curve shows the flow value at constant Δp , depending on the solenoid current. The second curve describes the dependency of flow value and Δp at constant solenoid current. The total valve pressure drop (Δp) was measured between port P and T of the valve.

E 04 spool

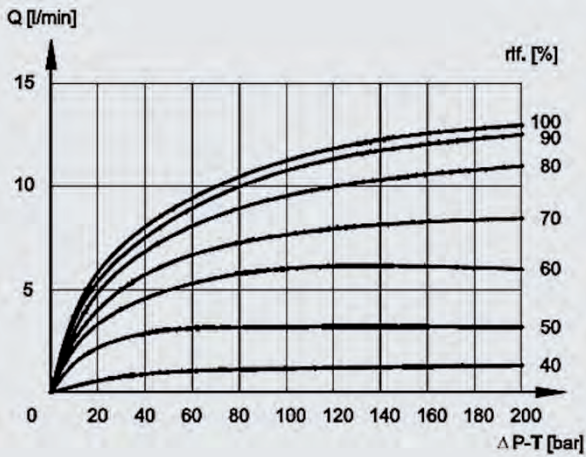
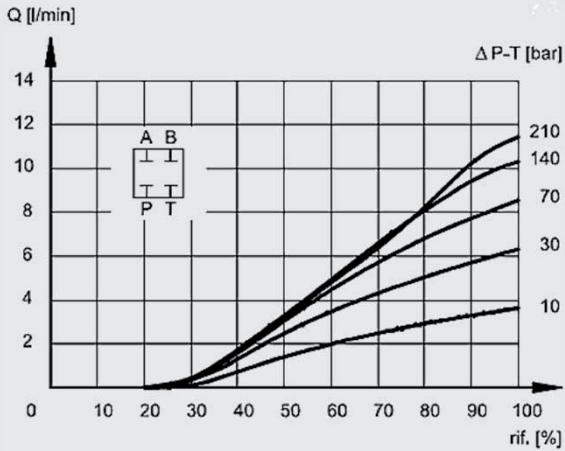

E 08 spool

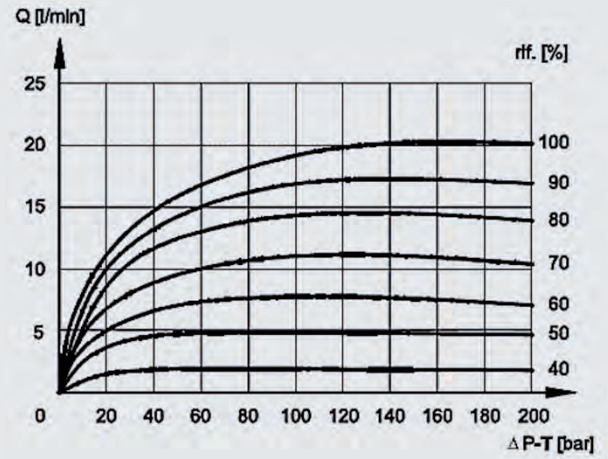
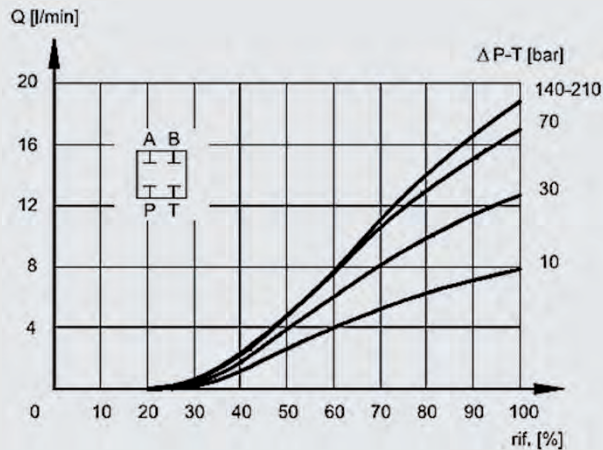

E / EA 16 spool

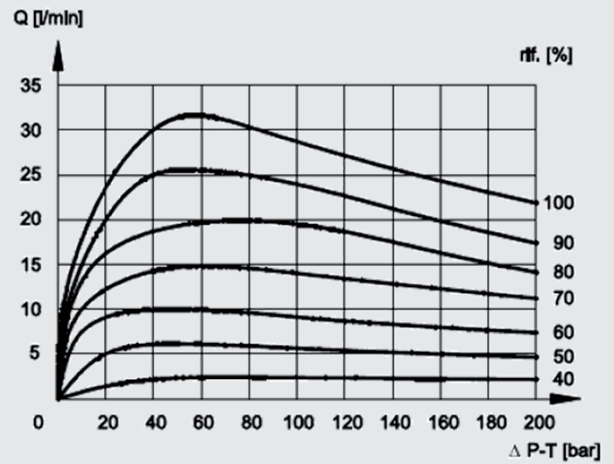
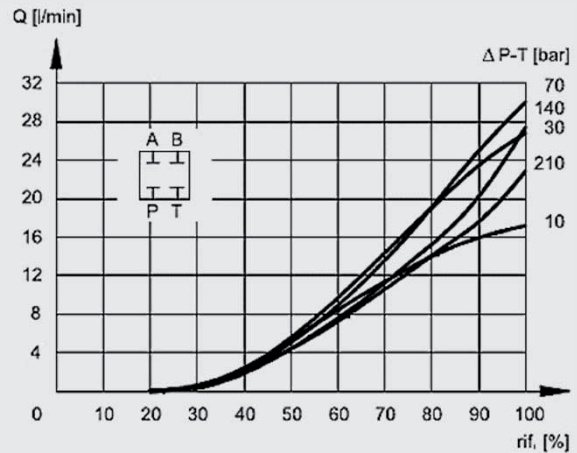

E / EA 26 spool

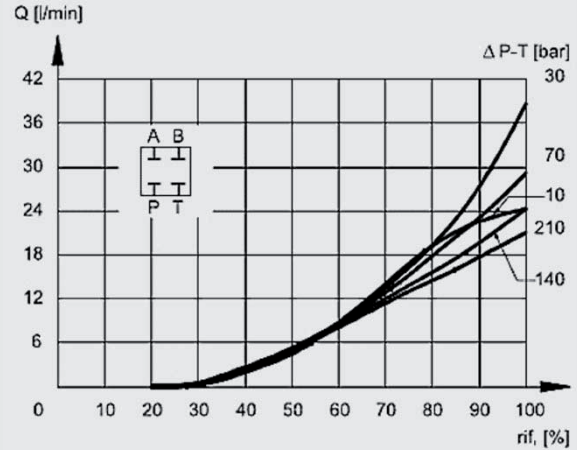

PERFORMANCE

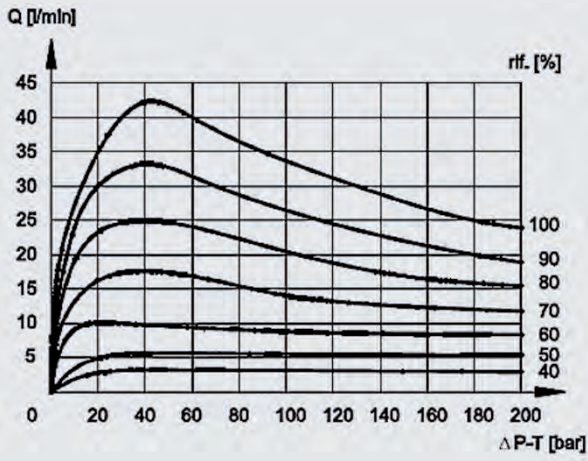

Q 04 spool

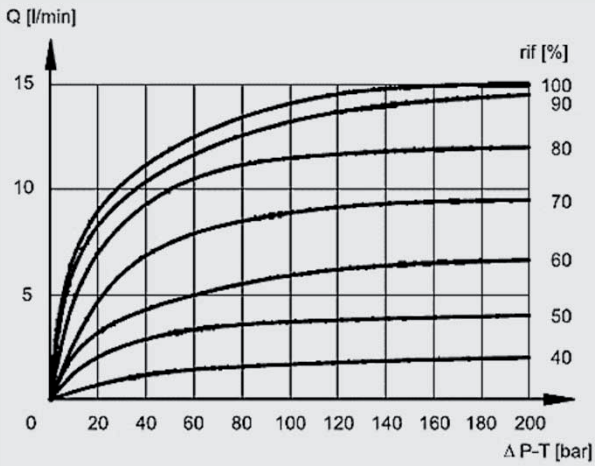
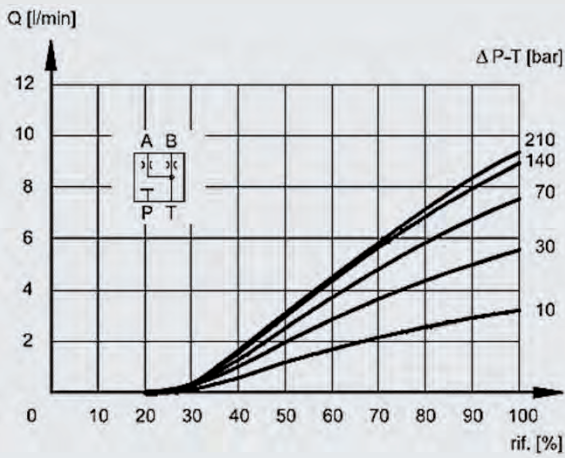

Q 08 spool

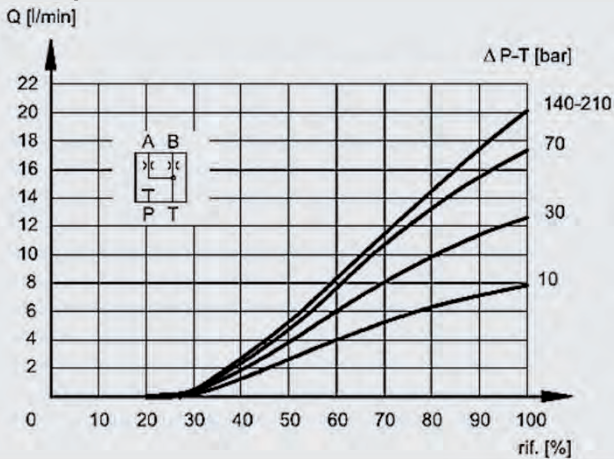

Q 16 spool

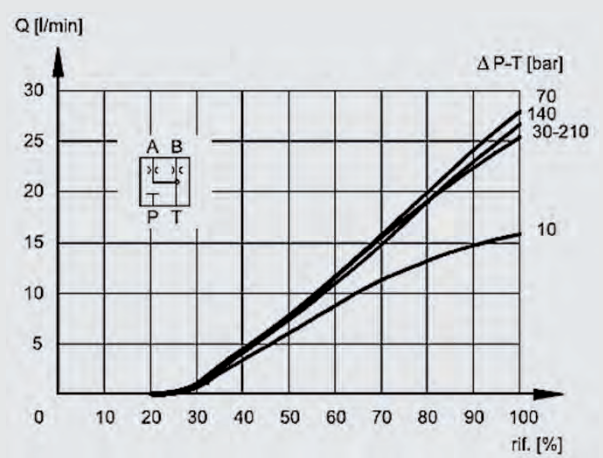

Q 26 spool

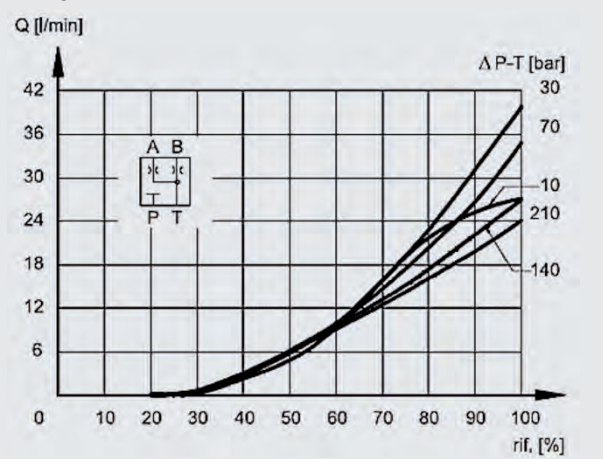

PERFORMANCE

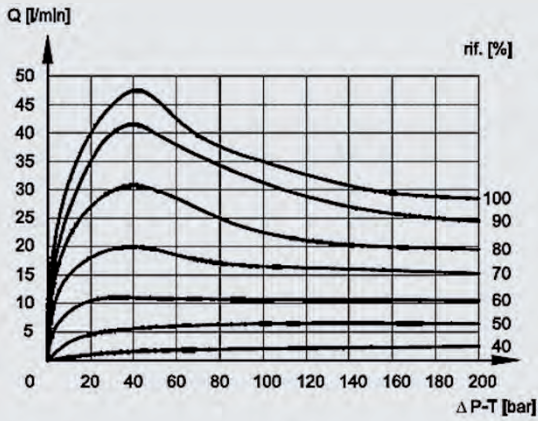

Switching time

measured at $T_{oil} = 50^\circ C$ and $36 \text{ mm}^2/s$

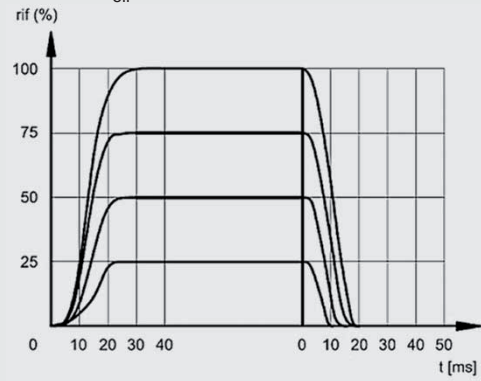

DIMENSIONS

INTERFACE

ISO 4401-03-02-0-05

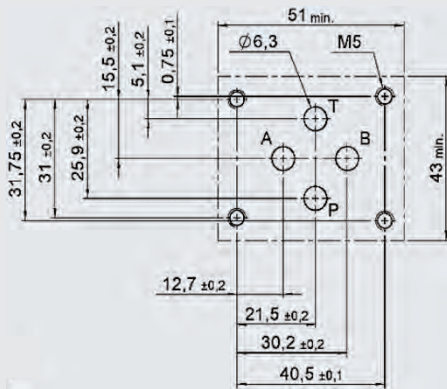

Main connector
(connector 7 Pin DIN 43563
- IP65 PG11 EX7S/L/10)
not included in delivery

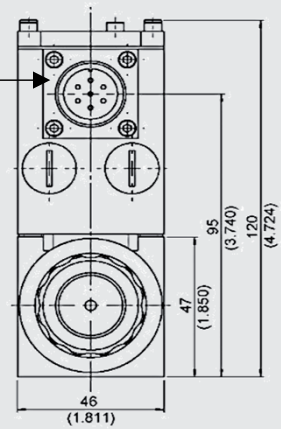

With two solenoids

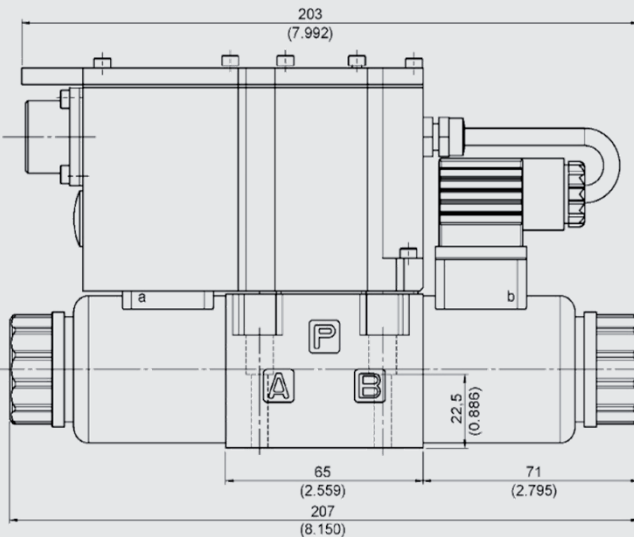

With one solenoid

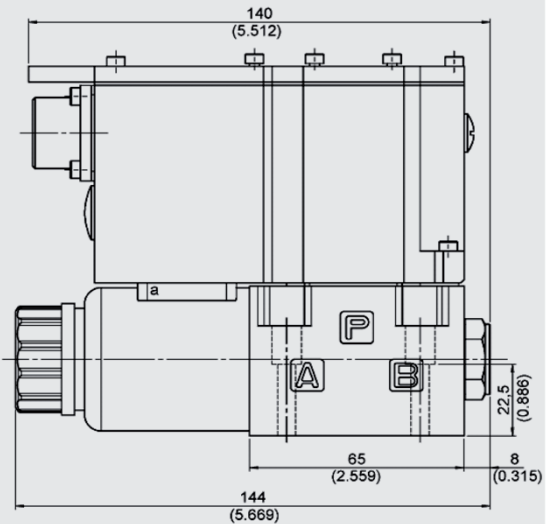

Standard
Nothand

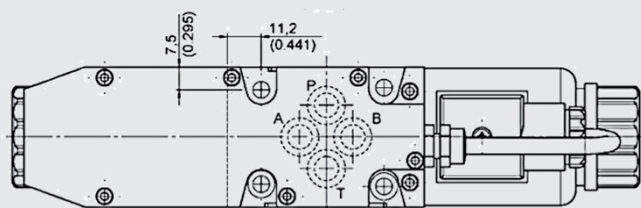

Mounting screws (ISO 4762): 4 pcs M5 x 30 A10.9 (not included in delivery)
Torque: 5 Nm

INTEGRATED ELECTRONIC

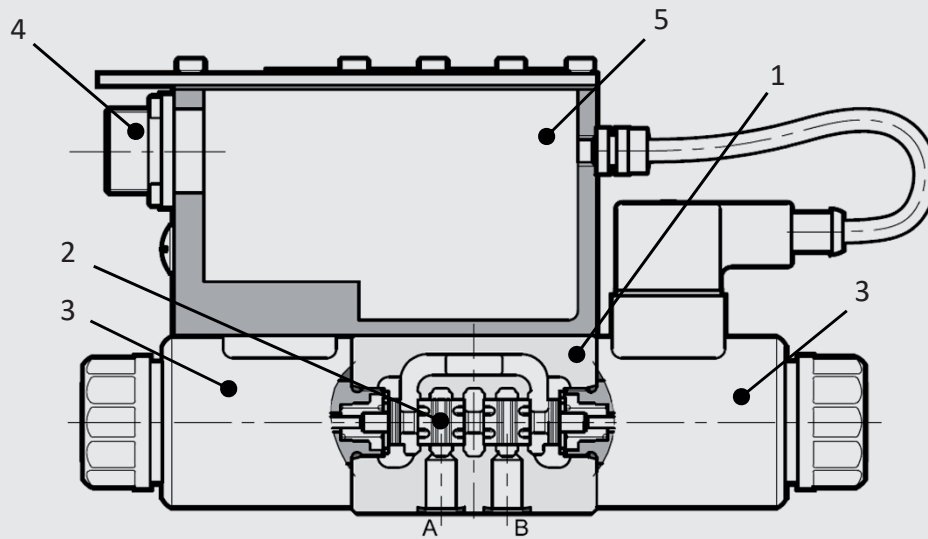

Parameterisable only via LIN bus

- 1) Valve with proportional solenoids
- 2) Valve piston
- 3) Proportional solenoid
- 4) Main connector
- 5) Electronic housing

General specifications

Power consumption:	25 W
Current consumption:	max. 1,88 A
Rated voltage:	24 V DC (19 – 30 V DC, ripple max. 3 Vpp)
Duty cycle:	100% ED (continuous)
Control signal E0:	Voltage signal ± 10 VDC
Control signal E1:	Current signal 4 – 20 mA
Alert signal:	Overload and overheating of electronics
Communication:	LIN-Bus ISO 11898 LIN-Bus Interface
Electronical connection:	7-pin MIL-C-5015-G (DIN-EN 175201-804)
LIN-Bus connection:	M12-IEC 60947-5-2
EMC EN61000-6-4:	According to 2014/30/EU standard
EMC EN61000-6-2:	According to 2014/30/EU standard
Type of protection:	IP65 / IP67 (CEI EN 60529 dstandard)

ELECTRONIC

Standard version with reference signal voltage E0

PIN	Value	Version A	Version B	Version C
A	24 V DC	Supply voltage		
B	0 V			
C		release 24 V DC	unoccupied	PIN F reference 0 V
D	± 10 V	control (differential input)		
E	0 V	PIN D reference		
F	± 10 V	monitor (0V reference PIN B)		monitor
PE	GND	earth (mass)		

Standard version with reference signal current E1

PIN	Value	Version A	Version B	Version C
A	24 V DC	Supply voltage		
B	0 V			
C		release 24 V DC	unoccupied	PIN F reference 0 V
D	4 - 20 mA	control		
E	0 V	PIN D reference		
F	4 - 20 mA	monitor (feedback) (0V reference PIN B)		monitor (feedback)
PE	GND	earth (mass)		

Diagrams PIN C Function

Version A: External release (on request)

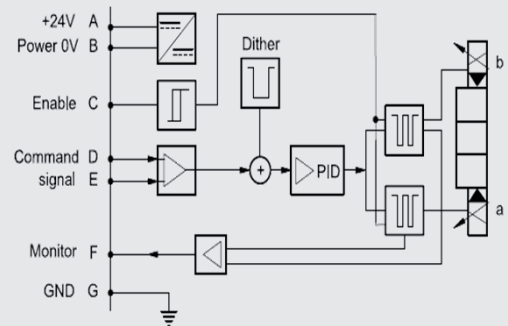

Version B: Internal release (standard)

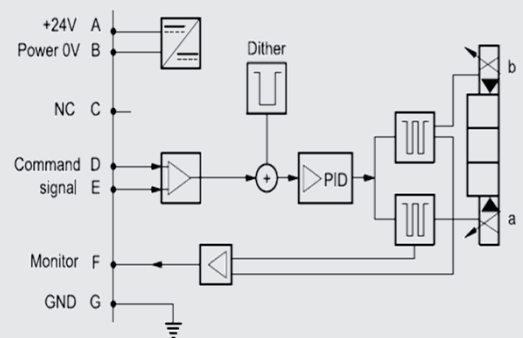

Version C: 0V Monitor (on request)

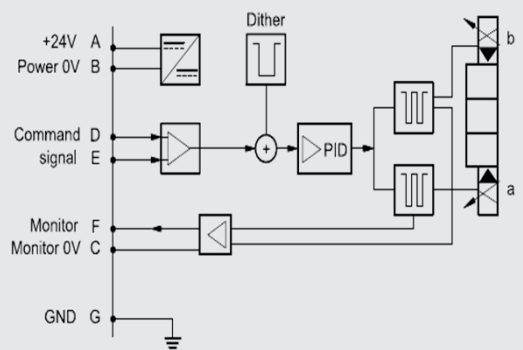

Hint 1

- Voltage signal (0V centring position)
 - -10V to 0 V: flow direction P – B and A – T
 - 0V to +10V: flow direction P – A und B – T
- Current signal (12 mA centring position)
 - 4 mA to 12 mA: flow direction P – B and A – T
 - 12 mA to 20 mA: flow direction P – A and B – T
- With one solenoid (type EA)
 - 4 mA to 20 mA: flow direction P – B and A – T
 - 0V to +10V: flow direction P – B and A – T

Pin D and Pin E must always be contacted.

Hint 2

PIN C function A and B: Nominal input value measured between pin F and pin B.

Hint 3

We recommend to provide an external protection at pin A (24 V DC) for protection of the electronics: 5A/50V fast fuse

LIN-BUS INTERFACE

Is also required for parameterisation of Onboard electronic

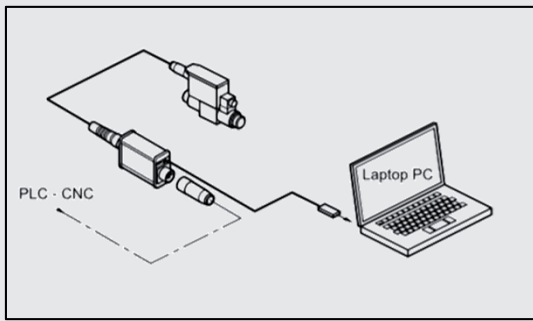

- The kit contains a test device with embedded connection cable 7 pin and a USB cable for connection to the PC. The dedicated software are available for download from our website.
- The device is suitable for troubleshooting and functional testing of HYDAC proportional valves with LIN-bus interface.
- The software allow the check of settings, display the diagnostic and permit to make changes on the standard parameter setting made in factory, adapting it to your system.
- No additional power supply is required: the device uses the supply source from the 7 PIN system cable.

Content*: Parameterize-software, adapter and PC connection cable

* On request (not included in delivery)

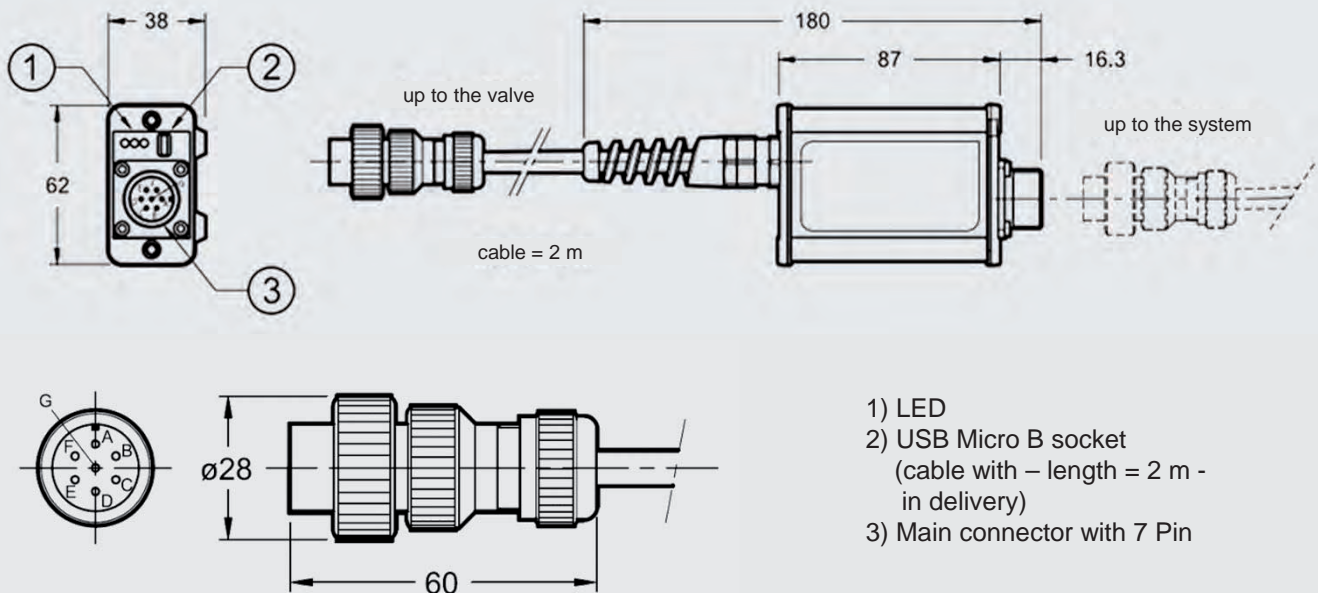

- 1) LED
- 2) USB Micro B socket
(cable with – length = 2 m -
in delivery)
- 3) Main connector with 7 Pin

In the casing of electronics, a 7-pole port for connecting with external devices is integrated.

The cable diameter for the main connector (cable and connector are not included in delivery) has to be min. 8 mm and should be max. 10 mm.

Hint

We recommend the use of a metal connector to ensure electromagnetic compatibility (EMC) and to avoid electromagnetic disturbances.

Note

The information in this brochure relates to the operating conditions and applications described. For applications not described, please contact the relevant technical department. All technical details are subject to change without notice.

HYDAC Fluidtechnik GmbH
Justus-von-Liebig-Str.
D-66280 Sulzbach/Saar
Tel: 0 68 97 /509-01
Fax: 0 68 97 /509-598
E-Mail: valves@hydac.com

4/3 proportional directional valves direct-acting with Onboard Electronic P4WEE 10

DESCRIPTION

HYDAC proportional valves of the P4WEE series are pilot stages for pilot operated proportional directional valves with Onboard Electronic, which combines directional control with speed control of the consumer.

The controlled volume flow is proportional to the electrical input signal on the solenoid.

The integrated digital electronics allows improved performance and function due to

- shorter response times
- reduced hysteresis
- better repeatability

FEATURES

- High flow capacity due to optimized, cast casing
- Low hysteresis due to precision machining of moving parts
- Integrated digital electronics
- Easy interchangeability due to internationally standardised interface according to ISO 4401

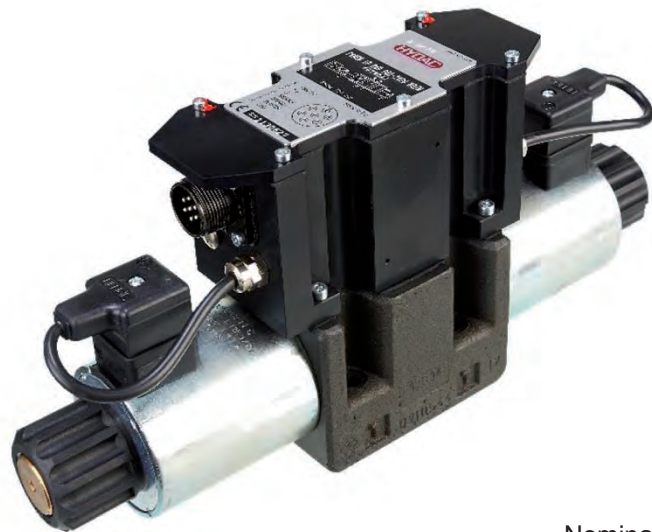

Nominal size 10
up to 90 l/min
up to 320 bar

CONTENT

Description
Features
Model code
Spool types / Symbols
Technical Data
Function
Section view
Accessories
Performance
Dimensions
Electronic

MODEL CODE

P4WEE 10 E 30 D01 – 24 PG E0 A /V

Type

Proportional directional valve
With integrated Onboard Electronic (OBE)

Nominal size (NG)

10

Symbol

see chapter „Spool types / Symbols“

Nominal flow (bei $\Delta p = 10 \text{ bar}$, $P \rightarrow T$)

30 = 30 l/min

60 = 60 l/min

Series

D01 = standard with manual override

Power supply

24 = 24 VDC

Coil type

PG = DIN Stecker nach EN175301-803

Input signal

E0 = $\pm 10 \text{ V}$

E1 = 4 – 20 mA

Pin C Function

see „Diagramms Pin C Function“ in chapter „Electronic“

Sealing material

V = FKM (standard)

N = NBR

SPOOL TYPES / SYMBOLS

Type	Basic symbol	Type	Basic symbol
E		Q	
EA			

FUNCTION

The proportional valves of the P4WEE series are direct-acting valves with integrated Onboard Electronic.

The volume flow is controlled continuously (proportionally) to the electrical input signal at the solenoid coil.

The valve consists of a valve casing (1), a control piston (2) and two proportional solenoids (3).

The proportional solenoid coils are controlled via the integrated Onboard electronic (4).

According to the input signal, the solenoid generates a force and shifts the piston against a spring. This releases cross-sections P-B-A-T or P-A-B-T, which define the size of the volume flow, depending on the pressure difference at the relevant control element.

SECTION VIEW

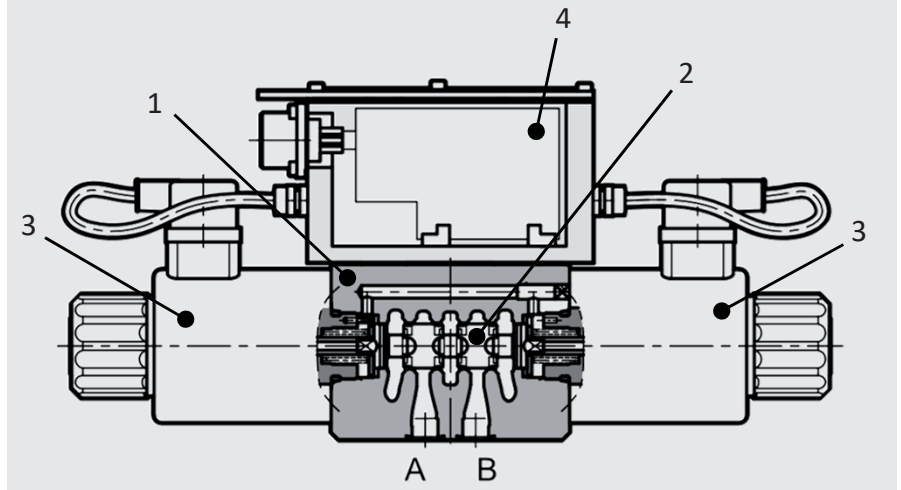

ACCESSORIES

	Designation	Part no.
Seal kits	12,45 x 1,78 90 Sh FKM	3524439
(4-part set)	12,45 x 1,78 90 Sh NBR	3524438
Mounting screws	ISO 4762 M6 x 40 (4 pcs)	3524314
Main connector	6+PE EN175201 Part 804	6080324
Electronic	Lin-Bus Interface	3648934

TECHNICAL DATA ¹

General specifications			
MTTF _d :	To EN ISO 13849-1:2015 chart C1 & C2		
Ambient temperature:	[°C]	-20 to +60	
Installation position:	No orientation restrictions		
Weight:	[kg]	6,6	
Material:	Valve casing:	Cast iron	
	Name plate:	Aluminium	
Surface coating:	Valve casing:	Phosphate	
Hydraulic specifications			
Operating pressure:	[bar]	Port P, A, B:	$p_{max} = 320$
		Port T:	$p_{max} = 140$
Flow: ($\Delta p = 10 \text{ bar}$, P→T)	[l/min]	30, 60	
Operating fluid:	Hydraulic oil to DIN 51524 part 1, 2 and 3		
Media operating temperature range:	[°C]	-20 to +80	
Viscosity range:	[mm ² /s]	10 – 400	
Permitted contamination level of operating fluid:	class 18/16/13 to ISO 4406		
Sealing material:	NBR, FKM (standard)		
Electrical specifications			
Switching time (0 → 100%):	[ms]	See chapter „Performance“	
Switching time (100% → 0):	[ms]		
Type of voltage:	[V]	DC	
Rated voltage:	[A]	24	
Hysteresis:	[%]	< 3,0 of Q_{max}	
Repeatability:	[%]	< ±1,0 of Q_{max}	
Protection class to DIN EN 60529:	with electrical connection "G" IP65 ² /IP67 ²		

¹ see „Conditions and Instructions for Valves“ in brochure 53.000

² if installed correctly

PERFORMANCE

measured at $T_{oil} = 50^{\circ}\text{C}$ and $36 \text{ mm}^2/\text{s}$

The performance curves represent typical flow curves for different valve pistons. The first curve shows the flow value at constant Δp , depending on the solenoid current. The second curve describes the dependency of flow value and Δp at constant solenoid current. The total valve pressure drop (Δp) was measured between port P and T of the valve.

E / EA 30 spool

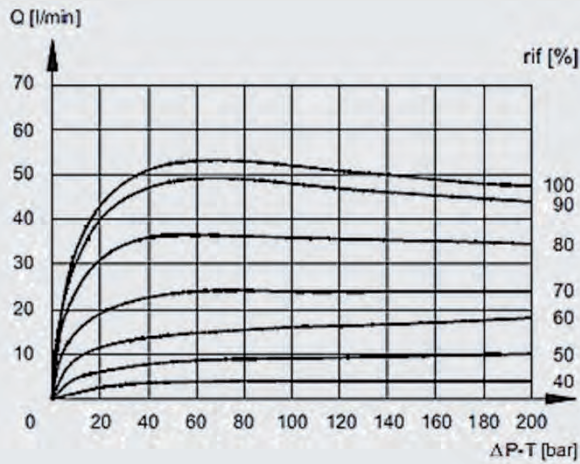
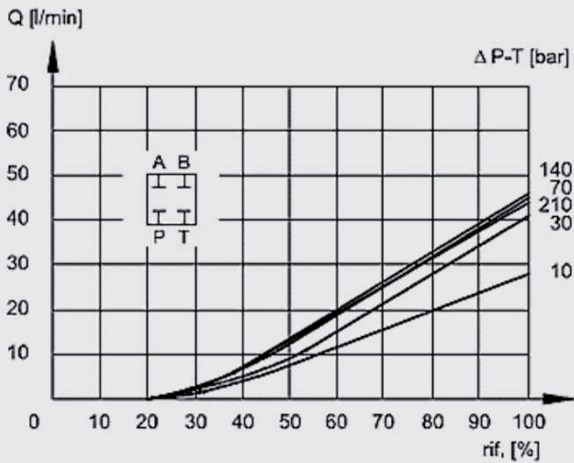

E / EA 60 spool

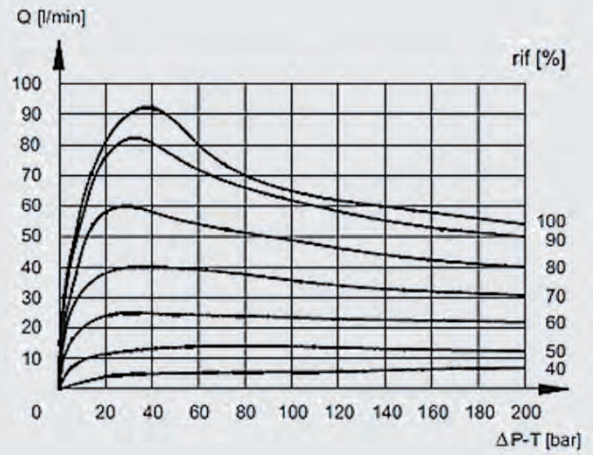
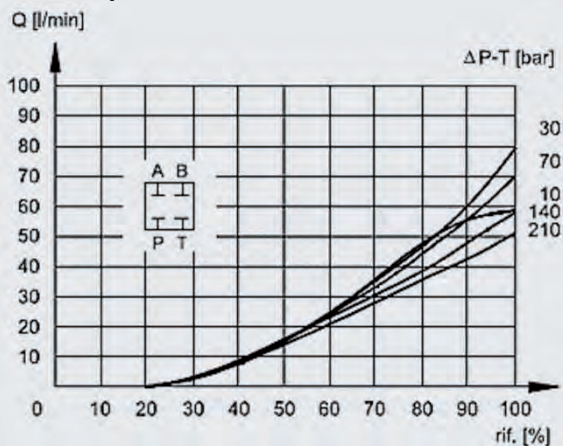

Q 30 spool

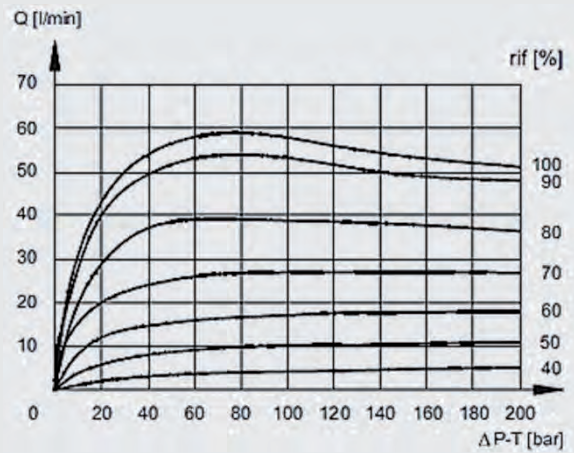
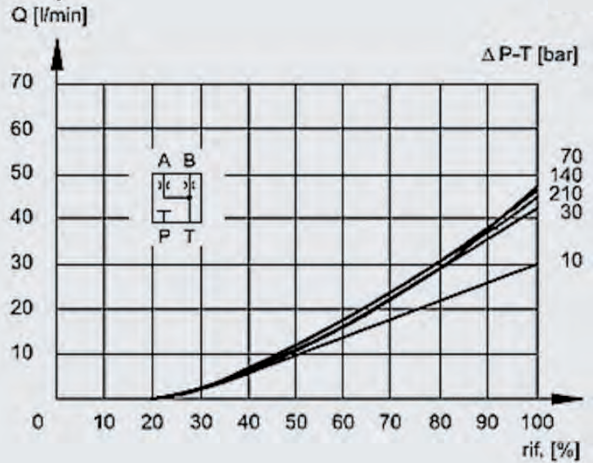

Q 60 spool

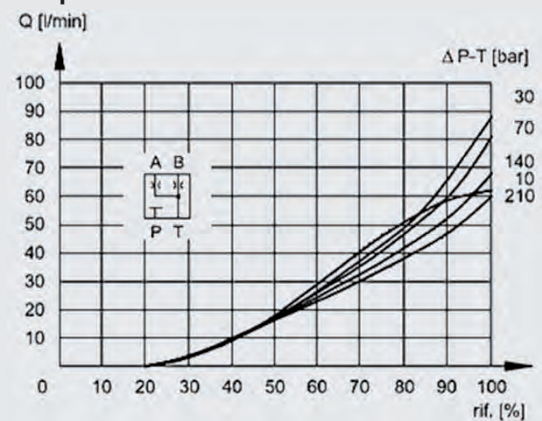

PERFORMANCE

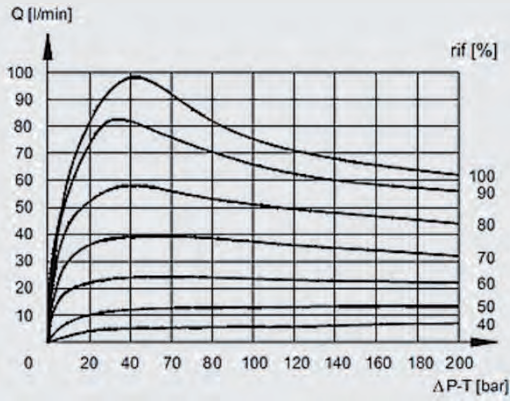

Switching time

measured at $T_{oil} = 50^\circ C$ and $36 \text{ mm}^2/s$, $p = 140 \text{ bar}$

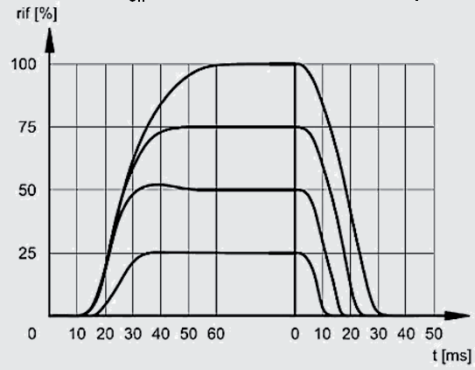

DIMENSIONS

INTERFACE

ISO 4401-05-04-0-05

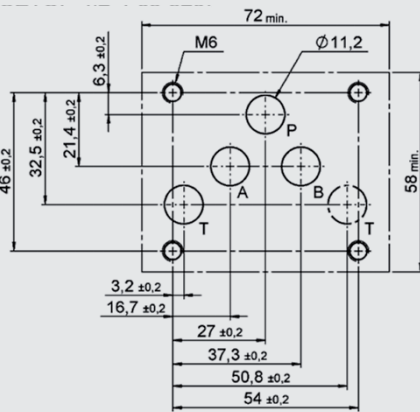

Main connector
(connector 7 Pin DIN 43563
- IP65 PG11 EX7S/L/10)
not included in delivery

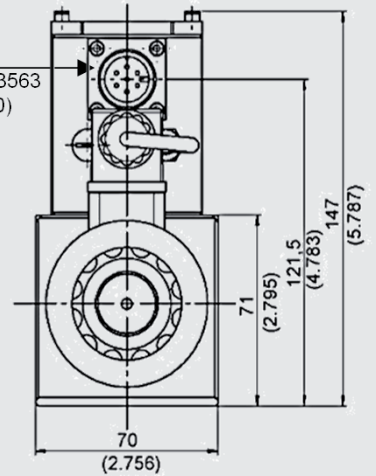

With two solenoids

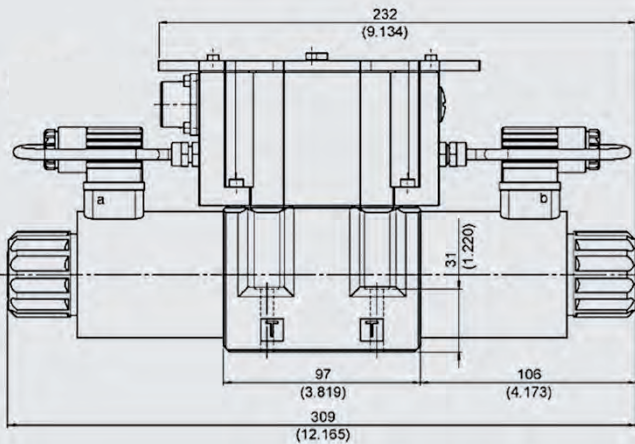

With one solenoid

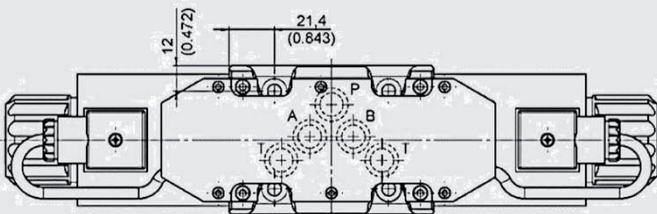
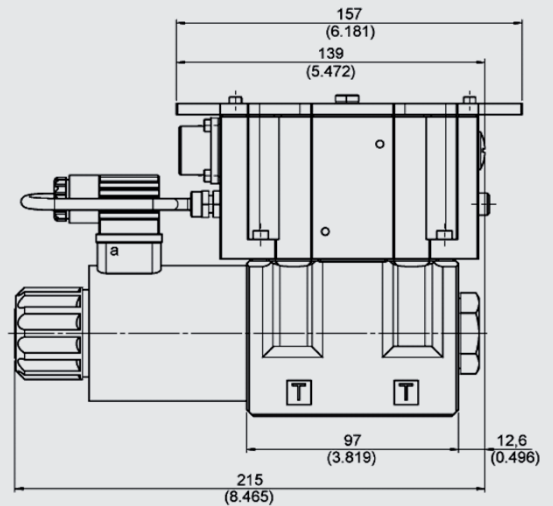

Mounting screws (ISO 4762): 4 pcs M6 x 40 A10.9 (not included in delivery)
Torque: 8 Nm

INTEGRATED ELECTRONIC

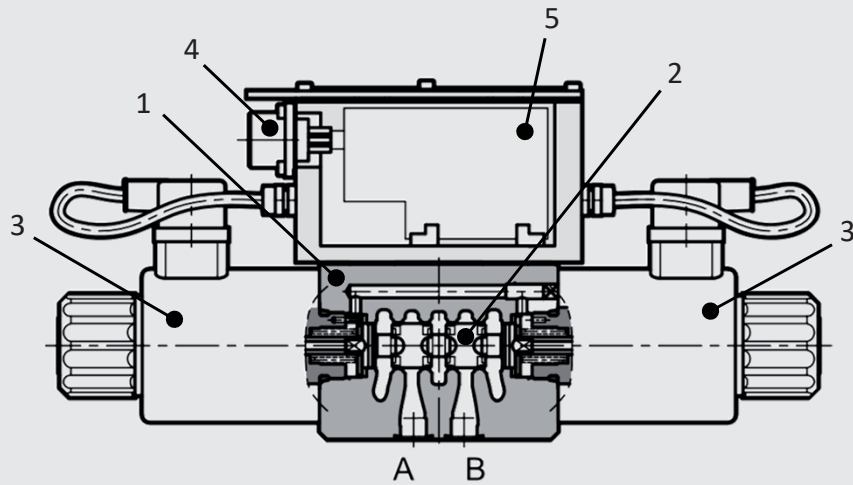

Parameterisable only via LIN bus

- 1) Valve with proportional solenoids
- 2) Valve piston
- 3) Proportional solenoid
- 4) Main connector
- 5) Electronic housing

General specifications

Power consumption:	40 W
Current consumption:	max. 2,8 A
Rated voltage:	24 V DC (19 – 30 V DC, ripple max. 3 Vpp)
Duty cycle:	100% ED (continuous)
Control signal E0:	Voltage signal ± 10 VDC
Control signal E1:	Current signal 4 – 20 mA
Alert signal:	Overload and overheating of electronics
Communication:	LIN-Bus ISO 11898 LIN-Bus Interface
Electronical connection:	7-pin MIL-C-5015-G (DIN-EN 175201-804)
LIN-Bus connection:	M12-IEC 60947-5-2
EMC EN61000-6-4:	According to 2014/30/EU standard
EMC EN61000-6-2:	According to 2014/30/EU standard
Type of protection:	IP65 / IP67 (CEI EN 60529 standard)

ELEKTRONIC

Standard version with reference signal voltage E0

PIN	Value	Version A	Version B	Version C
A	24 V DC	Supply voltage		
B	0 V			
C		release 24 V DC	unoccupied	PIN F reference 0 V
D	+/- 10 V	control (differential input)		
E	0 V	PIN D reference		
F	+/- 10 V	monitor (0V reference PIN B)		monitor
PE	GND	earth (mass)		

Standard version with reference signal current E1

PIN	Value	Version A	Version B	Version C
A	24 V DC	Supply voltage		
B	0 V			
C		release 24 V DC	unoccupied	PIN F reference 0 V
D	4 - 20 mA	control		
E	0 V	PIN D reference		
F	4 - 20 mA	monitor (meedback) (0V reference PIN B)		monitor (meedback)
PE	GND	earth (mass)		

Diagramms PIN C Function

Version A: External release (on request)

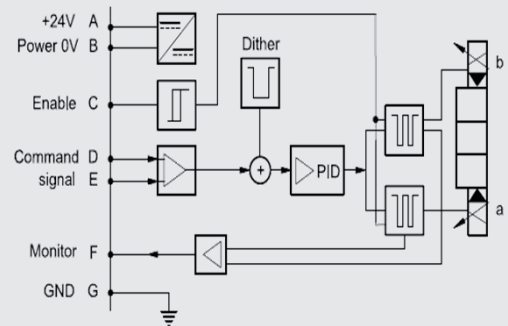

Version B: Internal release (standard)

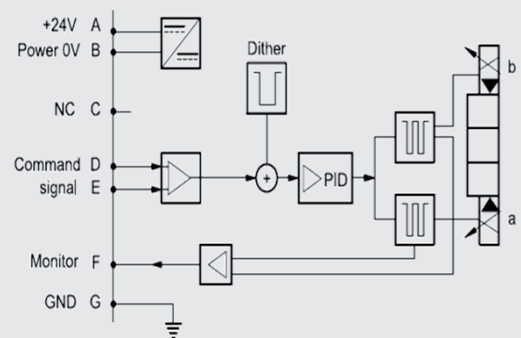

Version C: 0V Monitor (on request)

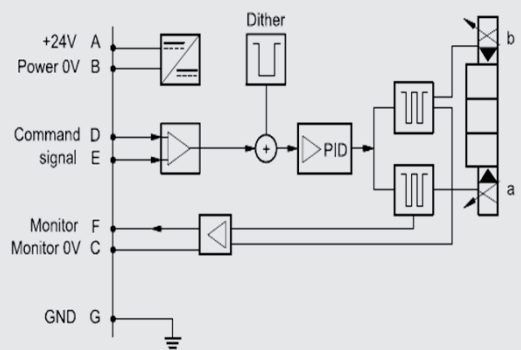

Hint 1

- Voltage signal (0V centring position)
 - -10V to 0 V: flow direction P – B and A – T
 - 0V to +10V: flow direction P – A und B – T
- Current signal (12 mA centring position)
 - 4 mA to 12 mA: flow direction P – B and A – T
 - 12 mA to 20 mA: flow direction P – A and B – T
- With one solenoid (type EA)
 - 4 mA to 20 mA: flow direction P – B and A – T
 - 0V to +10V: flow direction P – B and A – T

Pin D and Pin E must always be contacted.

Hint 2

PIN C function A and B: Nominal input value measured between pin F and pin B.

Hint 3

We recommend to provide an external protection at pin A (24 V DC) for protection of the electronics: 5A/50V fast fuse

LIN-BUS INTERFACE

Is also required for parameterisation of Onboard electronic

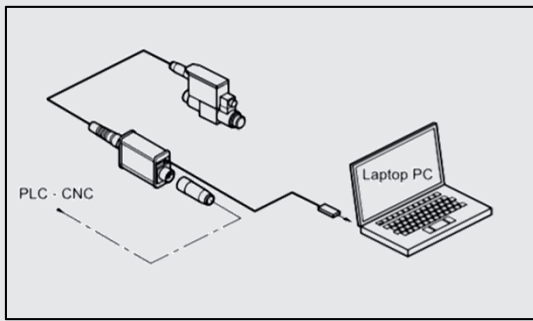

- The kit contains a test device with embedded connection cable 7 pin and a USB cable for connection to the PC. The dedicated software are available for download from our website.
- The device is suitable for troubleshooting and functional testing of HYDAC proportional valves with LIN-bus interface.
- The software allow the check of settings, display the diagnostic and permit to make changes on the standard parameter setting made in factory, adapting it to your system.
- No additional power supply is required: the device uses the supply source from the 7 PIN system cable.

Content*: Parameterize-software, adapter and PC connection cable

* On request (not included in delivery)

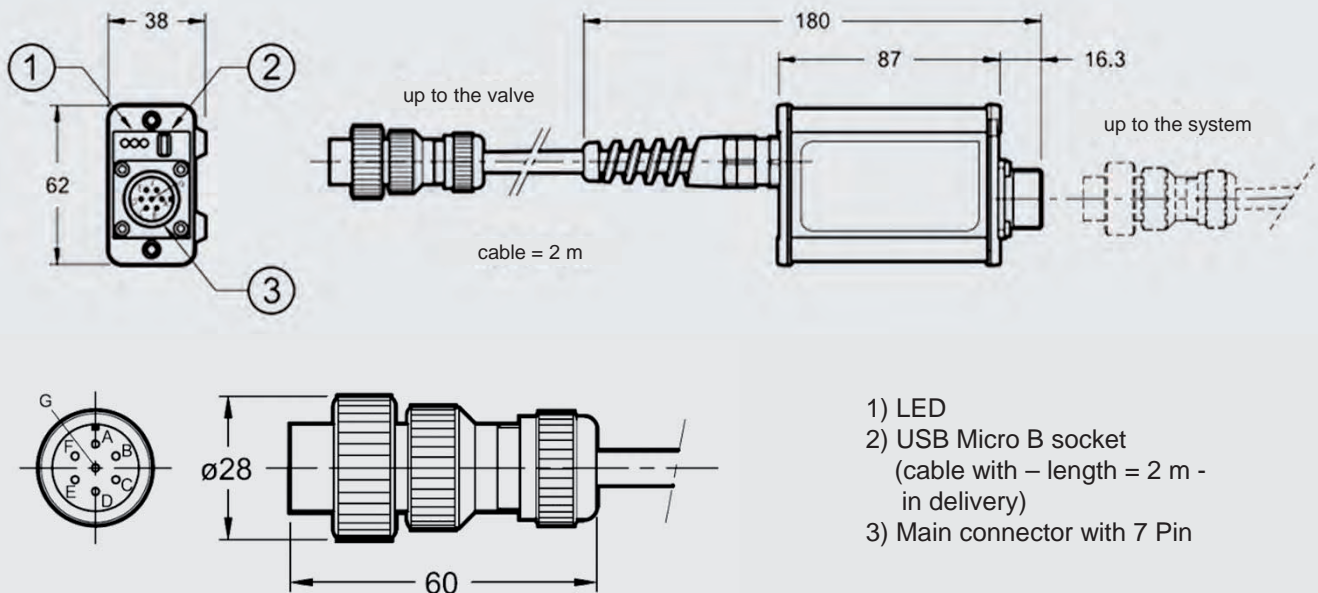

In the casing of electronics, a 7-pole port for connecting with external devices is integrated.

The cable diameter for the main connector (cable and connector are not included in delivery) has to be min. 8 mm and should be max. 10 mm.

Hint

We recommend the use of a metal connector to ensure electromagnetic compatibility (EMC) and to avoid electromagnetic disturbances.

Note

The information in this brochure relates to the operating conditions and applications described. For applications not described, please contact the relevant technical department. All technical details are subject to change without notice.

HYDAC Fluidtechnik GmbH
Justus-von-Liebig-Str.
D-66280 Sulzbach/Saar
Tel: 0 68 97 /509-01
Fax: 0 68 97 /509-598
E-Mail: valves@hydac.com

4/3 proportional directional valves direct-acting with Onboard Electronic and transducer P4WERE 06

DESCRIPTION

HYDAC proportional directional valves of the P4WERE series combines directional control with speed control of the consumer.

The controlled volume flow is proportional to the electrical input signal on valve electronics.

The integrated digital electronics in combination with the transducer allows improved performance and function due to

- regulation of size and direction of a volume flow
- short response times
- low hysteresis
- high repeatability

FEATURES

- High flow capacity due to optimized, cast casing
- Low hysteresis due to precision machining of moving parts
- With integrated Onboard Electronic and transducer
- Easy interchangeability due to internationally standardised interface according to ISO 4401

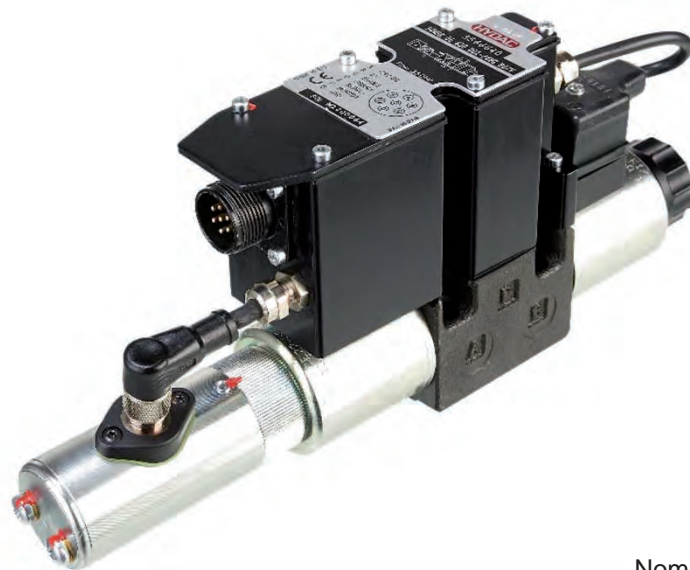

Nominal size 6
up to 80 l/min
up to 350 bar

CONTENT

Description
Features
Model code
Spool types / Symbols
Technical Data
Function
Section view
Accessories
Performance
Dimensions
Electronic

MODEL CODE

P4WERE 06 E 12 D01 – 24 PG E0 A /V

Type

Proportional directional valve
with Onboard Electronic (OBE) and transducer

Nominal size (NG)

6

Symbol

see chapter „Spool types / Symbols“

Nominal flow (at $\Delta p = 10 \text{ bar}$, $P \rightarrow T$)

04 = 4 l/min (spool Z only)

12 = 12 l/min

30 = 30 l/min

Series

D01 = standard with manual override

Power supply

24 = 24 VDC

Coil Type

PG = DIN connector to EN175301-803

Input signal

E0 = $\pm 10 \text{ V}$

E1 = 4 – 20 mA

Pin C Function

see „Diagramms Pin C Function“ in chapter „Electronic“

Sealing material

V = FKM (standard)

N = NBR

SPOOL TYPES / SYMBOLS

Type	Basic symbol	Type	Basic symbol
E		Q	
Z			

FUNCTION

The proportional valves of the P4WERE series are direct-acting valves with integrated Onboard Electronic.

The volume flow is controlled continuously (proportionally) to the electrical input signal at the solenoid coil.

The valve consists of a valve casing (1), a control piston (2), as well as a transducer (5) and two proportional solenoids (3).

The proportional solenoid coils are controlled via the integrated Onboard electronic (OBE) (4).

According to the input signal, the solenoid generates a force and shifts the piston against a spring. This releases cross-sections, which define the size of the volume flow, depending on the pressure difference at the relevant control element.

SECTION VIEW

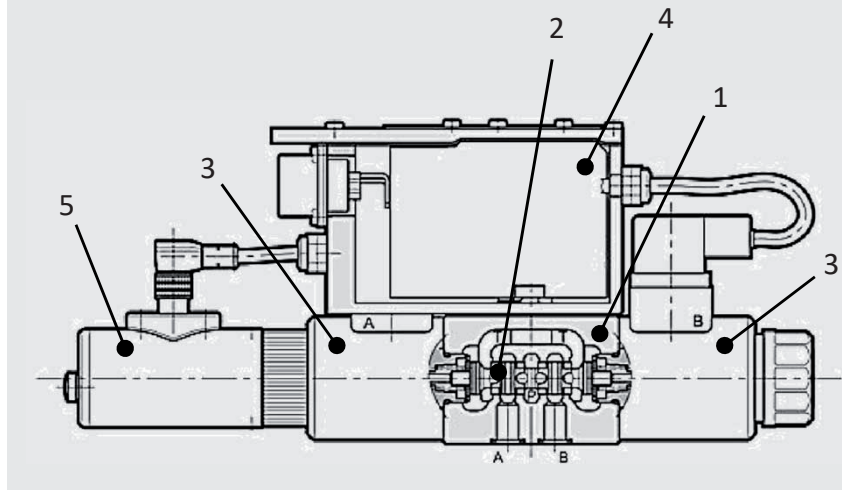

ACCESSORIES

	Designation	Part no.
Seal kits	9,25 x 1,78 90 Sh FKM	3524413
(4-part set)	9,25 x 1,78 90 Sh NBR	3524355
Mounting screws	ISO 4762 M5 x 30 (4 pcs)	3524313
Main connector	6+PE EN175201 Part 804	6080324
Electronic	Lin-Bus Interface	3648934

TECHNICAL DATA ¹

General specifications	
MTTF _d :	To EN ISO 13849-1:2015 chart C1 & C2
Ambient temperature:	[°C] -20 to +60
Installation position:	No orientation restrictions
Weight:	[kg] 2,7
Material:	Valve casing: Cast iron Name plate: Aluminium
Surface coating:	Valve casing: Phosphate
Hydraulic specifications	
Operating pressure:	[bar] Port P, A, B: p _{max} = 350 Port T: p _{max} = 210
max. flow: (Δp = 10 bar, P→T)	[l/min] 80
Operating fluid:	Hydraulic oil to DIN 51524 part 1, 2 and 3
Media operating temperature range:	[°C] -20 to +80
Viscosity range:	[mm ² /s] 10 – 400
Permitted contamination level of operating fluid:	class 18/16/13 to ISO 4406
Sealing material:	NBR, FKM (standard)
Electrical specifications	
Switching time (0 → 100%):	[ms] See chapter „Performance“
Switching time (100% → 0):	[ms]
Type of voltage:	[V] DC
Rated voltage:	[A] 24
Hysteresis:	[%] < 0,2 of Q _{max}
Repeatability:	[%] < 0,2 of Q _{max}
Protection class to DIN EN 60529:	with electrical connection "G" IP65 ² /IP67 ²

¹ see „Conditions and Instructions for Valves“ in brochure 53.000

² if installed correctly

PERFORMANCE

measured at $T_{oil} = 50^{\circ}\text{C}$ and $36 \text{ mm}^2/\text{s}$, $p = 140 \text{ bar}$

The performance represent typical curves for the various available valve pistons, at a constant Δp , depending on the current supplied by the solenoid coil.

The total valve pressure drop (Δp) was measured between port P and T of the valve.

E / Q 12 spool

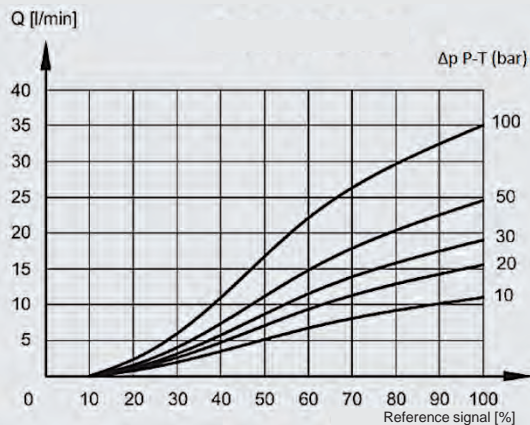

E / Q 30 spool

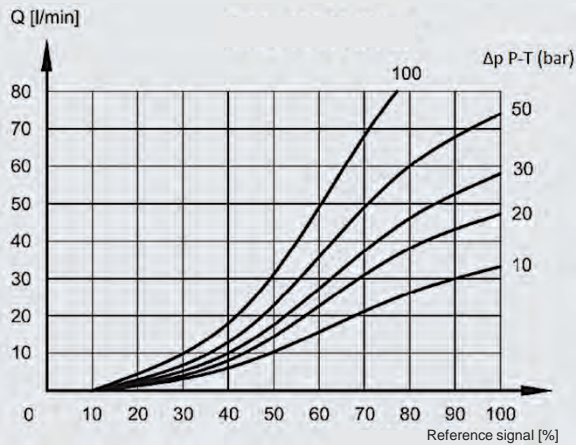

Z 04 spool

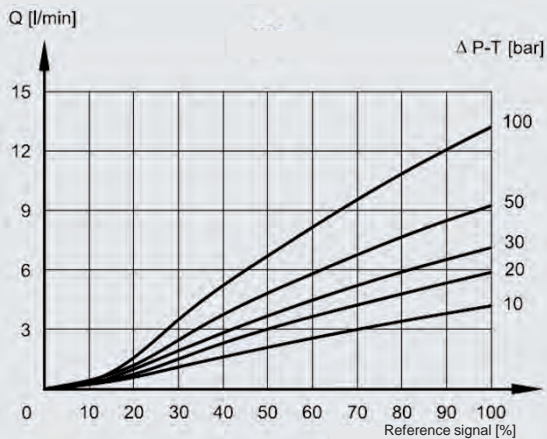

Z 12 spool

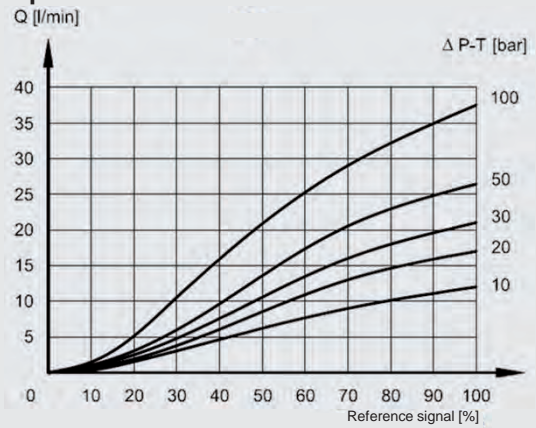

Z 30 spool

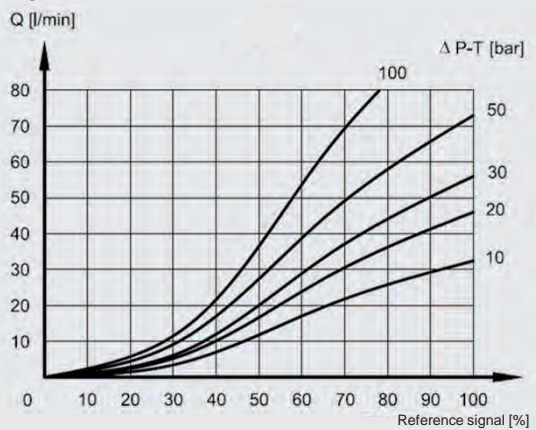

Frequency response Z spool

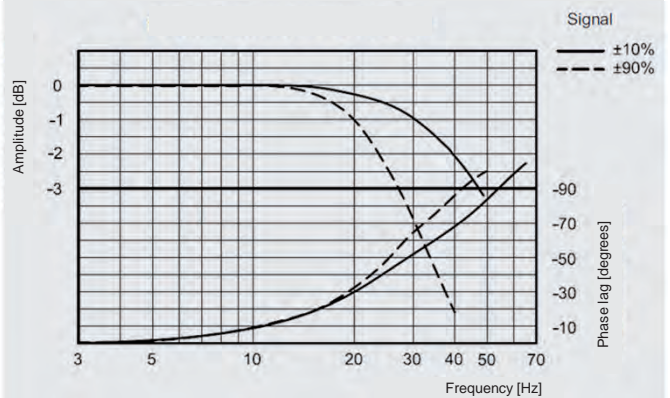

Switching time

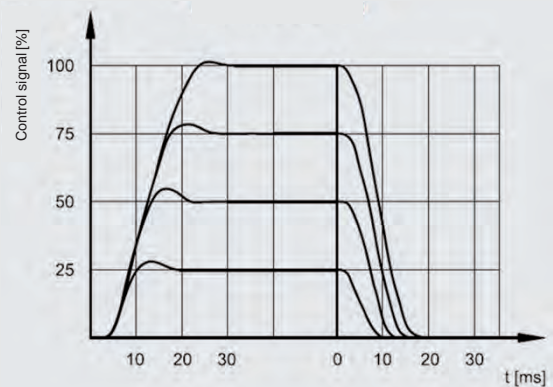

PERFORMANCE

Pressure gain Z spool

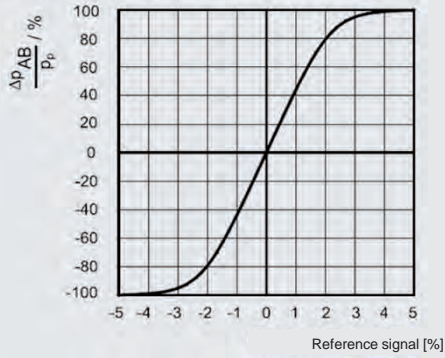

DIMENSIONS

INTERFACE

ISO 4401-03-02-0-05

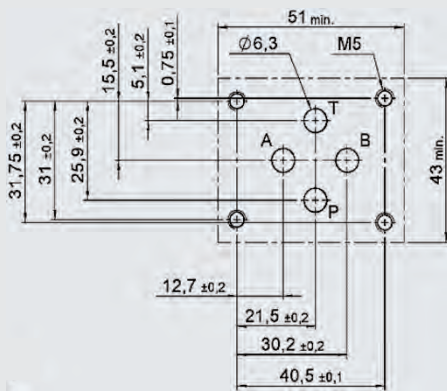

Main connector
(connector 7 Pin DIN
43563 - IP65 PG11
EX7S/L/10)
not included in delivery

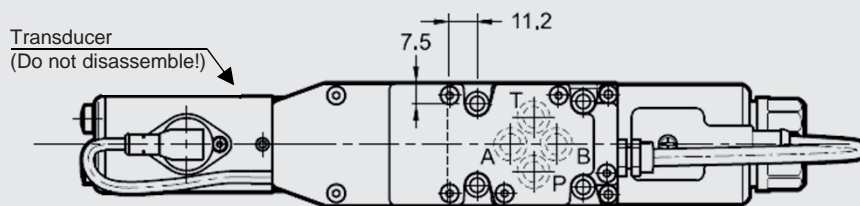
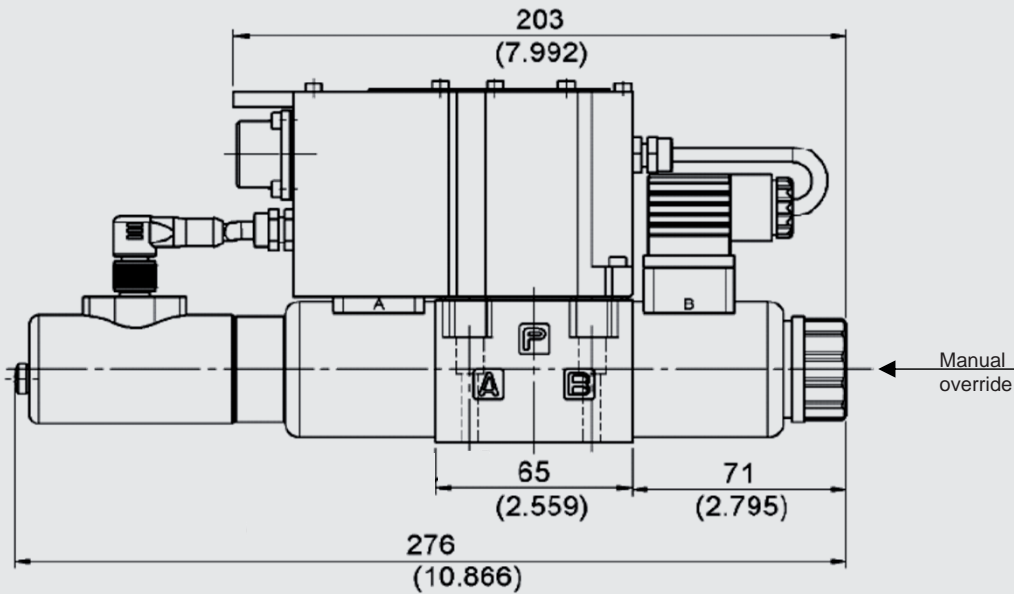
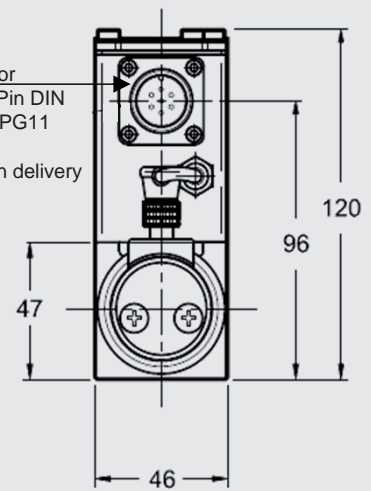

Mounting screws (ISO 4762): 4 pcs M5 x 30 A10.9 (not included in delivery)
Torque: 5 Nm

INTEGRATED ELECTRONIC

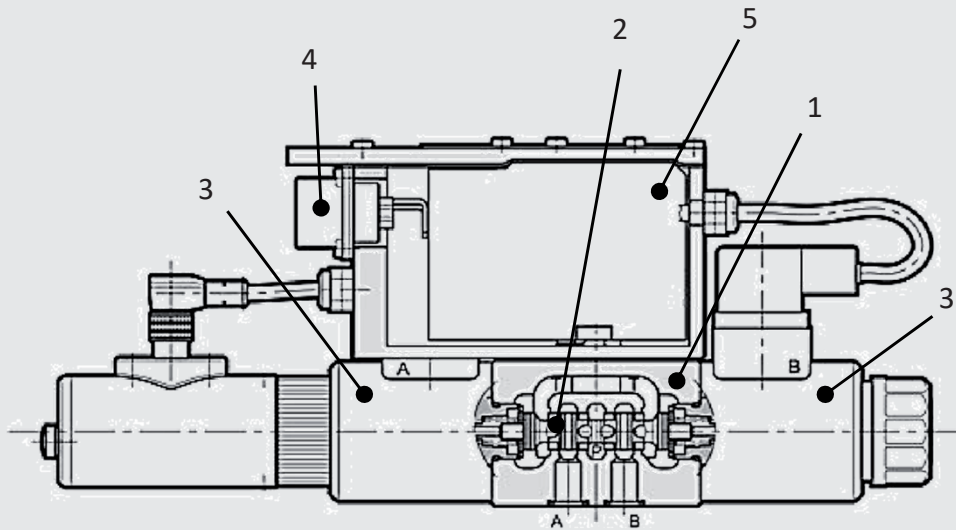

Parameterisable only via LIN bus

- 1) Valve with proportional solenoids
- 2) Valve piston
- 3) Proportional solenoid
- 4) Main connector
- 5) Electronic housing

General specifications

Power consumption:	25 W
Current consumption:	max. 1,88 A
Rated voltage:	24 V DC (19 – 30 V DC, ripple max. 3 Vpp)
Duty cycle:	100% ED (continuous)
Control signal E0:	Voltage signal ± 10 VDC
Control signal E1:	Current signal 4 – 20 mA
Alert signale:	Overload and overheating of electronics
Communication:	LIN-Bus ISO 11898 LIN-Bus Interface
Electronical connection:	7-pin MIL-C-5015-G (DIN-EN 175201-804)
LIN-Bus connection:	M12-IEC 60947-5-2
EMC EN61000-6-4:	According to 2014/30/EU standard
EMC EN61000-6-2:	According to 2014/30/EU standard
Type of protection:	IP65 / IP67 (CEI EN 60529 standard)

ELEKTRONIC

Standard version with reference signal voltage E0

PIN	Value	Version A	Version B	Version C
A	24 V DC	Supply voltage		
B	0 V			
C		release 24 V DC	unoccupied	PIN F reference 0 V
D	+/- 10 V	control (differential input)		
E	0 V	PIN D reference		
F	+/- 10 V	monitor (0V reference PIN B)		monitor
PE	GND	earth (mass)		

Standard version with reference signal current E1

PIN	Value	Version A	Version B	Version C
A	24 V DC	Supply voltage		
B	0 V			
C		release 24 V DC	unoccupied	PIN F reference 0 V
D	4 - 20 mA	control		
E	0 V	PIN D reference		
F	4 - 20 mA	monitor (feedback) (0V reference PIN B)		monitor (feedback)
PE	GND	earth (mass)		

Diagramms PIN C Function

Version A: External release (on request)

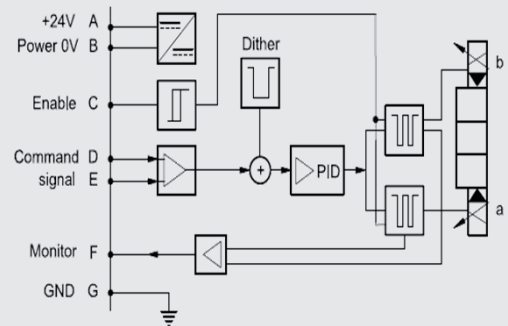

Version B: Internal release (standard)

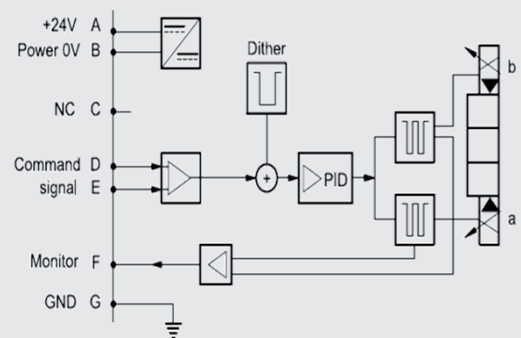

Version C: 0V Monitor (on request)

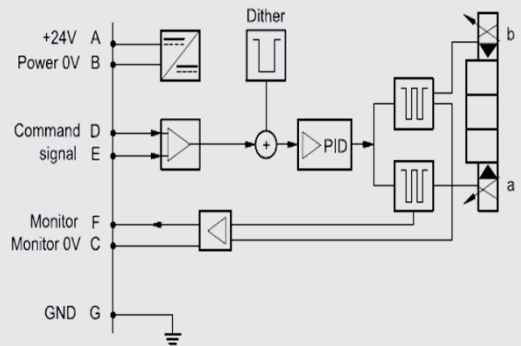

Hint 1

- Voltage signal (0V centring position)
 - -10V to 0 V: flow direction P – B and A – T
 - 0V to +10V: flow direction P – A und B – T
- Current signal (12 mA centring position)
 - 4 mA to 12 mA: flow direction P – B and A – T
 - 12 mA to 20 mA: flow direction P – A and B – T

Pin D and Pin E must always be contacted.

Hint 2

PIN C function A and B: Nominal input value measured between pin F and pin B.

Hint 3

We recommend to provide an external protection at pin A (24 V DC) for protection of the electronics: 5A/50V fast fuse.

LIN-BUS INTERFACE

Is also required for parameterisation of Onboard electronic

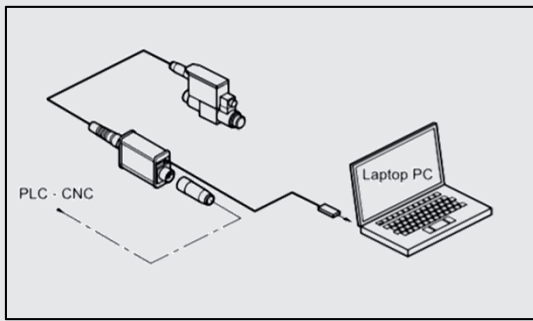

- The kit contains a test device with embedded connection cable 7 pin and a USB cable for connection to the PC. The dedicated software are available for download from our website.
- The device is suitable for troubleshooting and functional testing of HYDAC proportional valves with LIN-bus interface.
- The software allow the check of settings, display the diagnostic and permit to make changes on the standard parameter setting made in factory, adapting it to your system.
- No additional power supply is required: the device uses the supply source from the 7 PIN system cable.

Content*: Parameterize-software, adapter and PC connection cable

* On request (not included in delivery)

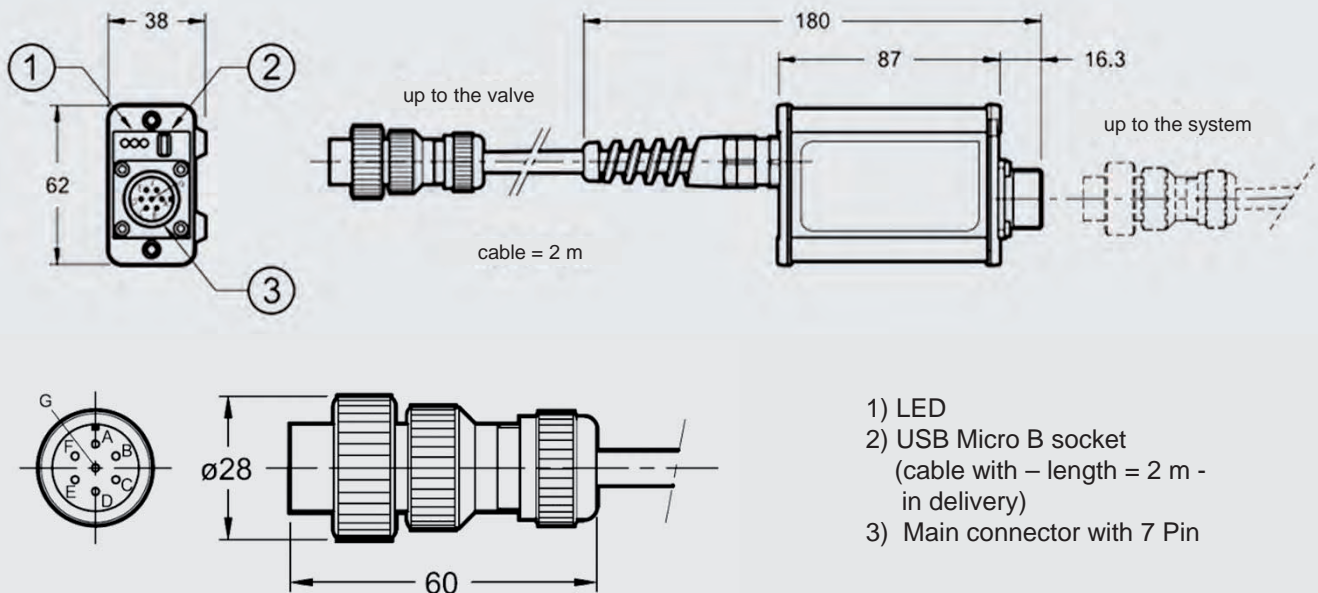

- 1) LED
- 2) USB Micro B socket
(cable with – length = 2 m - in delivery)
- 3) Main connector with 7 Pin

In the casing of electronics, a 7-pole port for connecting with external devices is integrated.

The cable diameter for the main connector (cable and connector are not included in delivery) has to be min. 8 mm and should be max. 10 mm.

Hint

We recommend the use of a metal connector to ensure electromagnetic compatibility (EMC) and to avoid electromagnetic disturbances.

Note

The information in this brochure relates to the operating conditions and applications described. For applications not described, please contact the relevant technical department. All technical details are subject to change without notice.

HYDAC Fluidtechnik GmbH
Justus-von-Liebig-Str.
D-66280 Sulzbach/Saar
Tel: 0 68 97 /509-01
Fax: 0 68 97 /509-598
E-Mail: valves@hydac.com

4/3 proportional directional valves direct-acting with Onboard Electronic and transducer P4WERE 10

DESCRIPTION

HYDAC proportional directional valves of the P4WERE series combines directional control with speed control of the consumer.

The controlled volume flow is proportional to the electrical input signal on valve electronics.

The integrated digital electronics in combination with the transducer allows improved performance and function due to

- regulation of size and direction of a volume flow
- short response times
- low hysteresis
- high repeatability

FEATURES

- High flow capacity due to optimized, cast casing
- Low hysteresis due to precision machining of moving parts
- With integrated Onboard Electronic and transducer
- Easy interchangeability due to internationally standardised interface according to ISO 4401

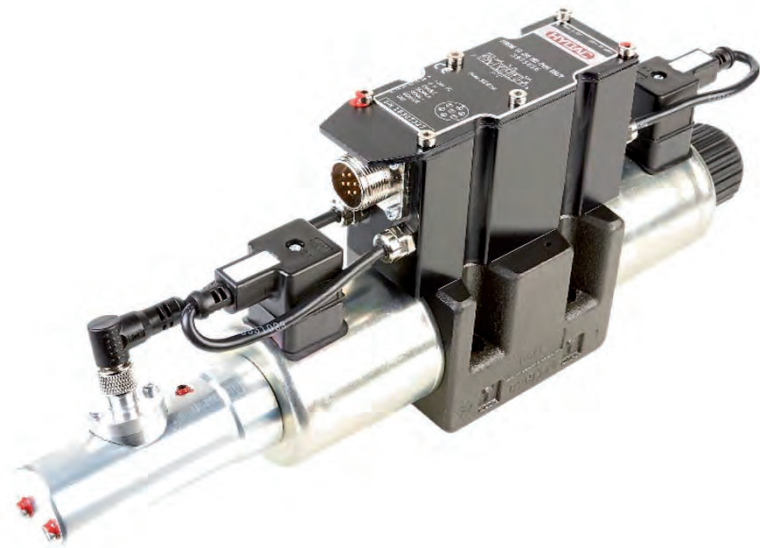

Nominal size 10
up to 180 l/min
up to 320 bar

CONTENT

Description

Features

Model code

Spool types / Symbols

Technical Data

Function

Section view

Accessories

Performance

Dimensions

Electronic

MODEL CODE

P4WERE 10 E 50 D01 – 24 PG E0 A /V

Type

Proportional directional valve
with Onboard Electronic (OBE) and transducer

Nominal size (NG)

10

Symbol

see chapter „Spool types / Symbols“

Nominal flow (at $\Delta p = 10 \text{ bar}$, $P \rightarrow T$)

50 = 50 l/min

50/25 = 50 l/min ($P \rightarrow A$) /25 l/min ($B \rightarrow T$)

70/35 = 70 l/min ($P \rightarrow A$) /35 l/min ($B \rightarrow T$)

75 = 75 l/min

Series

D01 = standard with manual override

Power supply

24 = 24 VDC

Coil Type

PG = DIN connector to EN175301-803

Input signal

E0 = $\pm 10 \text{ V}$

E1 = 4 – 20 mA

Pin C Function

see „Diagrams Pin C Function“ in chapter „Electronic“

Sealing material

V = FKM (standard)

N = NBR

SPOOL TYPES / SYMBOLS

Type	Basic symbol	Type	Basic symbol
E		Q	
Z			

FUNCTION

The proportional valves of the P4WERE series are direct-acting valves with integrated Onboard Electronic.

The volume flow is controlled continuously (proportionally) to the electrical input signal at the solenoid coil.

The valve consists of a valve casing (1), a control piston (2), as well as a transducer (5) and two proportional solenoids (3).

The proportional solenoid coils are controlled via the integrated Onboard electronic (OBE) (4).

According to the input signal, the solenoid generates a force and shifts the piston against a spring. This releases cross-sections, which define the size of the volume flow, depending on the pressure difference at the relevant control element.

SECTION VIEW

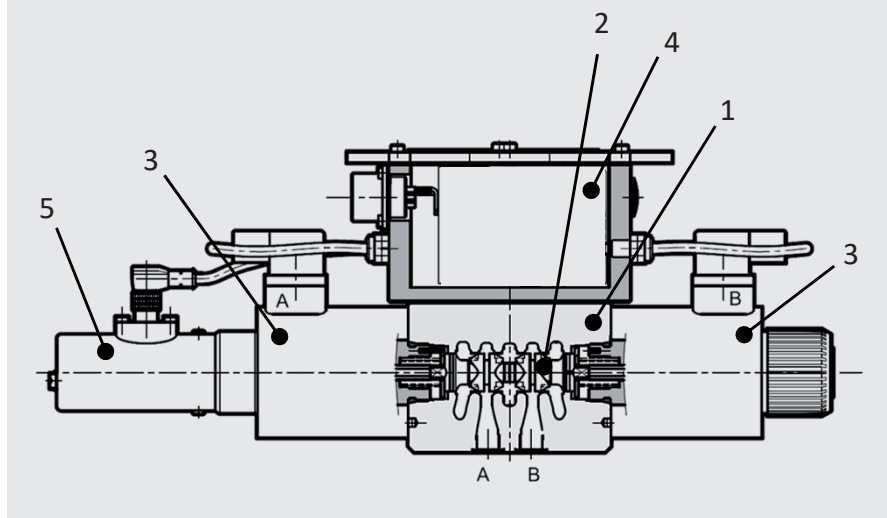

ACCESSORIES

	Designation	Part no.
Seal kits	12,45 x 1,78 90 Sh FKM	3524413
(4-part set)	12,45 x 1,78 90 Sh NBR	3524355
Mounting screws	ISO 4762 M6 x 40 (4 pcs)	3524313
Main connector	6+PE EN175201 Part 804	6080324
Electronic	Lin-Bus Interface	3648934

TECHNICAL DATA ¹

General specifications	
MTTF _d :	To EN ISO 13849-1:2015 chart C1 & C2
Ambient temperature:	[°C] -20 to +60
Installation position:	No orientation restrictions
Weight:	[kg] 7,1
Material:	Valve casing: Cast iron Name plate: Aluminium
Surface coating:	Valve casing: Phosphate
Hydraulic specifications	
Operating pressure :	[bar] Port P, A, B: p _{max} = 320 Port T: p _{max} = 210
max. flow: (Δp = 10 bar, P→T)	[l/min] 180
Operating fluid:	Hydraulic oil to DIN 51524 prst 1, 2 and 3
Media operating temperature range:	[°C] -20 to +80
Viscosity range:	[mm ² /s] 10 – 400
Permitted contamination level of operating fluid:	class 18/16/13 to ISO 4406
Sealing material:	NBR, FKM (standard)
Electrical specifications	
Switching time (0 → 100%):	[ms] See chapter „Performance“
Switching time (100% → 0):	[ms] See chapter „Performance“
Type of voltage:	[V] DC
Rated voltage:	[A] 24
Hysteresis:	[%] < 0,2 of Q _{max}
Repeatability:	[%] < ±0,1 of Q _{max}
Protection class to DIN EN 60529:	with electrical connection "G" IP65 ² /IP67 ²

¹ see „Conditions and Instructions for Valves“ in brochure 53.000

² if installed correctly

PERFORMANCE

measured at $T_{oil} = 50^{\circ}\text{C}$ and $36 \text{ mm}^2/\text{s}$, $p = 140 \text{ bar}$

The performance represent typical curves for the various available valve pistons, at a constant Δp , depending on the current supplied by the solenoid coil.

The total valve pressure drop (Δp) was measured between port P and T of the valve.

E / Q 50 spool

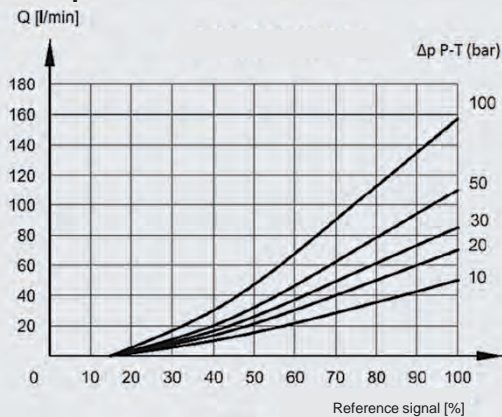

E / Q 75 spool

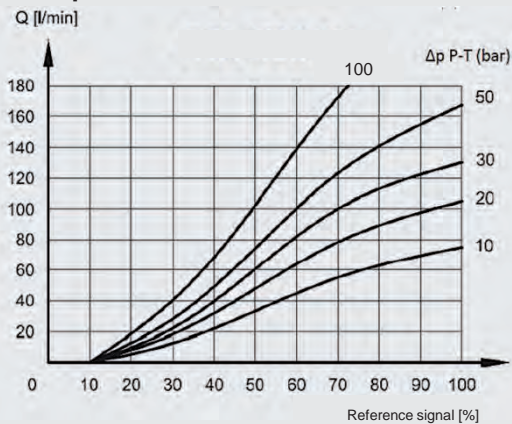

Z 50 spool

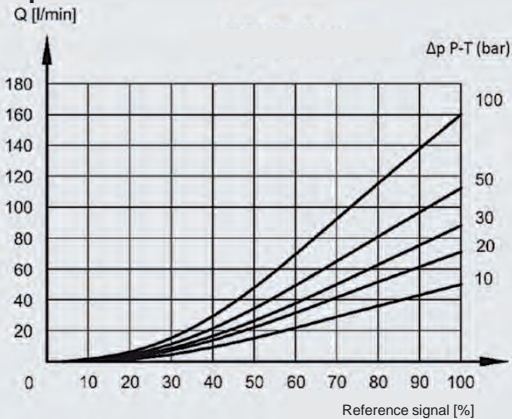

Z 75 spool

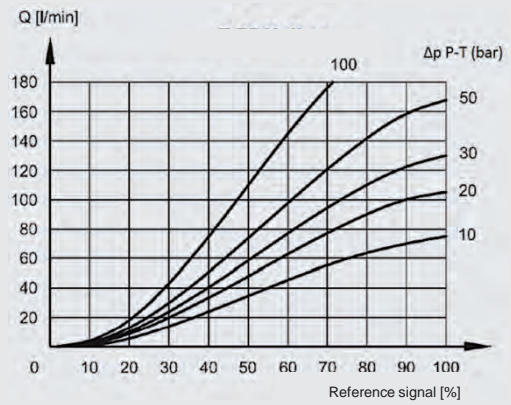

Switching time

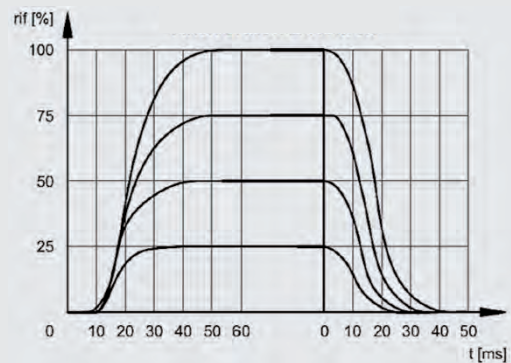

Frequency response Z spool

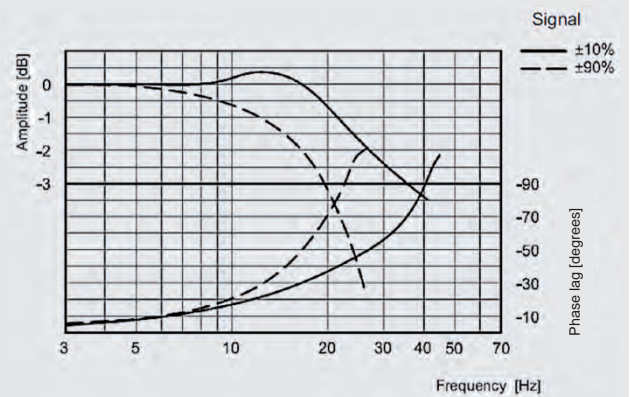

Pressure gain Z spool

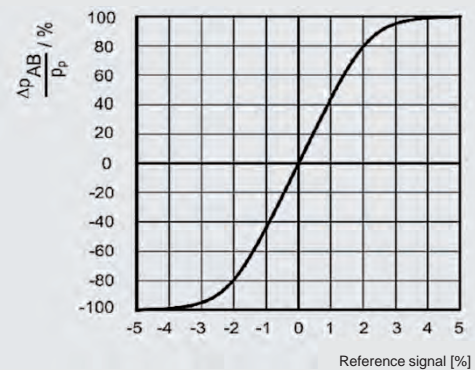

DIMENSIONS

INTERFACE

ISO 4401-05-04-0-05

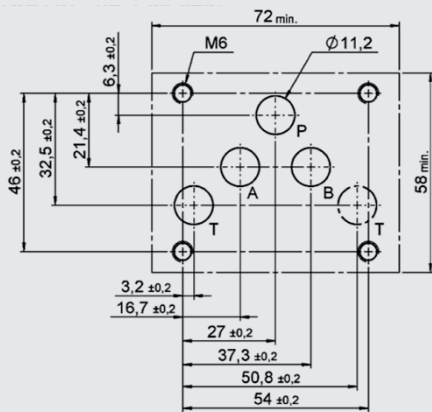

Main connector
(connector 7 Pin DIN
43563 - IP65 PG11
EX7S/L/10)
not included in delivery

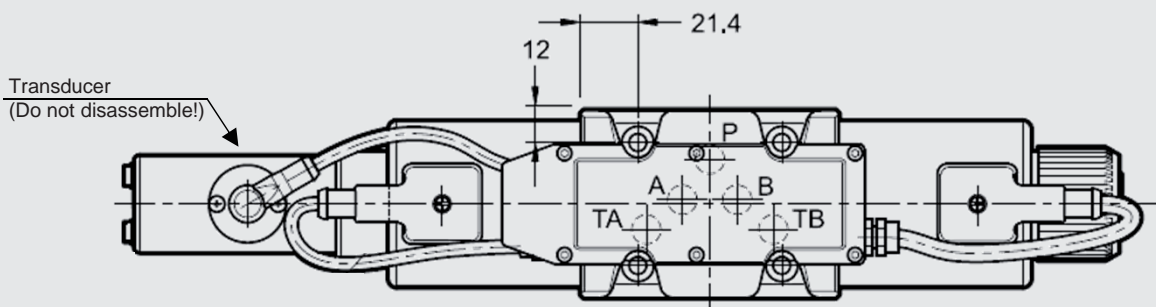
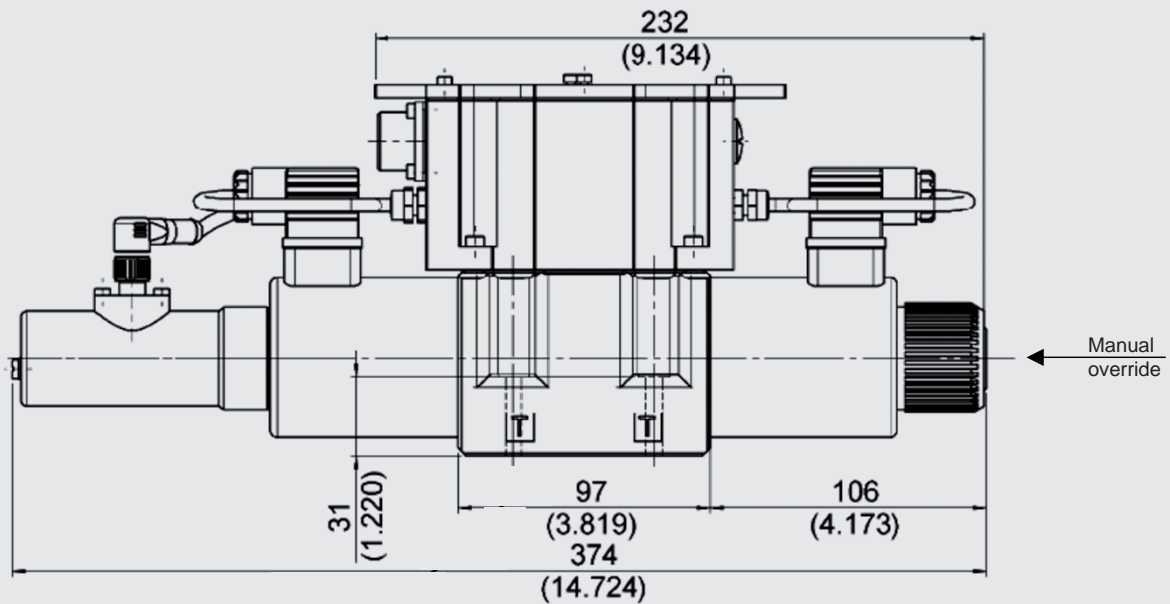
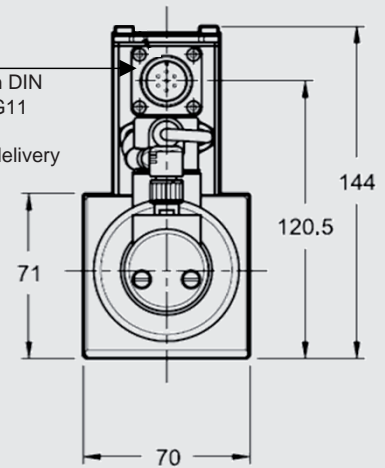

Transducer
(Do not disassemble!)

Mounting screws (ISO 4762): 4 pcs M6 x 40 A10.9 (not included in delivery)
Torque: 8 Nm

INTEGRATED ELECTRONIC

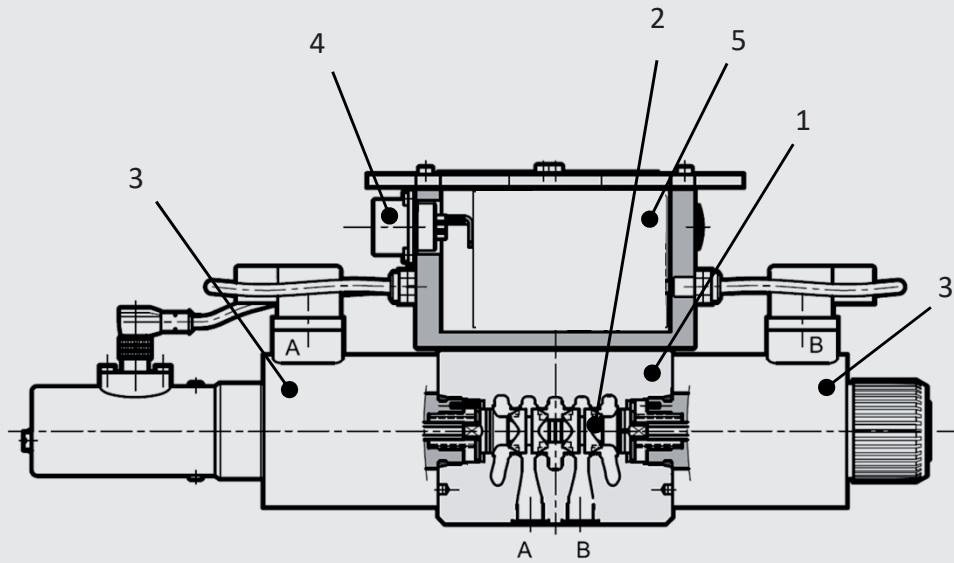

Parameterisable only via LIN bus

- 1) Valve with proportional solenoids
- 2) Valve piston
- 3) Proportional solenoid
- 4) Main connector
- 5) Electronic housing

General specifications

Power consumption:	40 W
Current consumption:	max. 2,8 A
Rated voltage:	24 V DC (19 – 30 V DC, ripple max. 3 Vpp)
Duty cycle:	100% ED (continuous)
Control signal E0:	Voltage signal ± 10 VDC
Control signal E1:	Current signal 4 – 20 mA
Alert signale:	Overload and overheating of electronics
Communication:	LIN-Bus ISO 11898 LIN-Bus Interface
Electronical connection:	7-pin MIL-C-5015-G (DIN-EN 175201-804)
LIN-Bus connection:	M12-IEC 60947-5-2
EMC EN61000-6-4:	According to 2014/30/EU standard
EMC EN61000-6-2:	According to 2014/30/EU standard
Type of protection:	IP65 / IP67 (CEI EN 60529 standard)

ELECTRONIC

Standard version with reference signal voltage E0

PIN	Value	Version A	Version B	Version C
A	24 V DC	Supply voltage		
B	0 V			
C		release 24 V DC	unoccupied	PIN F reference 0 V
D	+/- 10 V	control (differential input)		
E	0 V	PIN D reference		
F	+/- 10 V	monitor (0V reference PIN B)		monitor
PE	GND	earth (mass)		

Standard version with reference signal current E1

PIN	Value	Version A	Version B	Version C
A	24 V DC	Supply voltage		
B	0 V			
C		release 24 V DC	unoccupied	PIN F reference 0 V
D	4 - 20 mA	control		
E	0 V	PIN D reference		
F	4 - 20 mA	monitor (feedback) (0V reference PIN B)		monitor (feedback)
PE	GND	earth (mass)		

Diagramme PIN C Function

Version A: External release (on request)

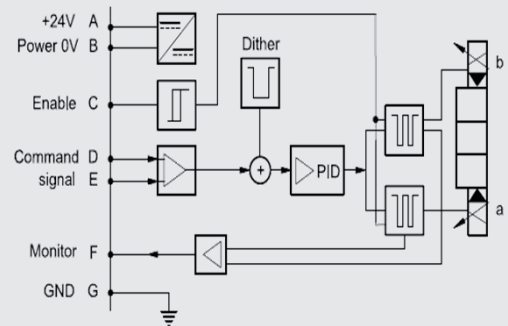

Version B: Internal release (standard)

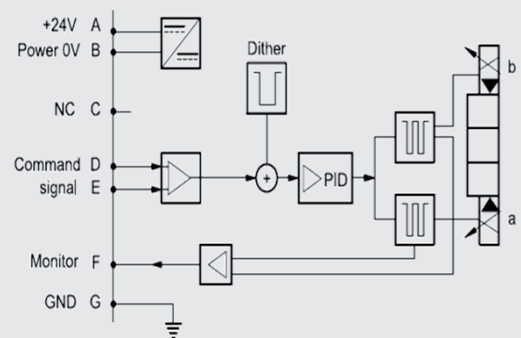

Version C: 0V Monitor (on request)

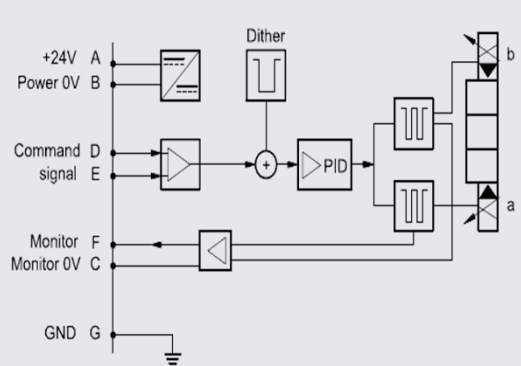

Hint 1

- Voltage signal (0V centring position)
 - -10V to 0 V: flow direction P – B and A – T
 - 0V to +10V: flow direction P – A und B – T
- Current signal (12 mA centring position)
 - 4 mA to 12 mA: flow direction P – B and A – T
 - 12 mA to 20 mA: flow direction P – A and B – T

Pin D and Pin E must always be contacted.

Hint 2

PIN C function A and B: Nominal input value measured between pin F and pin B.

Hint 3

We recommend to provide an external protection at pin A (24 V DC) for protection of the electronics: 5A/50V fast fuse.

LIN-BUS INTERFACE

Is also required for parameterisation of Onboard electronic

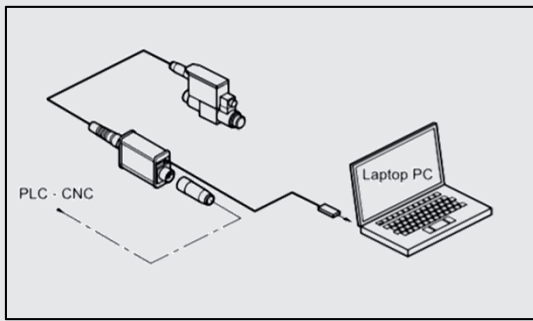

- The kit contains a test device with embedded connection cable 7 pin and a USB cable for connection to the PC. The dedicated software are available for download from our website.
- The device is suitable for troubleshooting and functional testing of HYDAC proportional valves with LIN-bus interface.
- The software allow the check of settings, display the diagnostic and permit to make changes on the standard parameter setting made in factory, adapting it to your system.
- No additional power supply is required: the device uses the supply source from the 7 PIN system cable.

Content*: Parameterize-software, adapter and PC connection cable

* On request (not included in delivery)

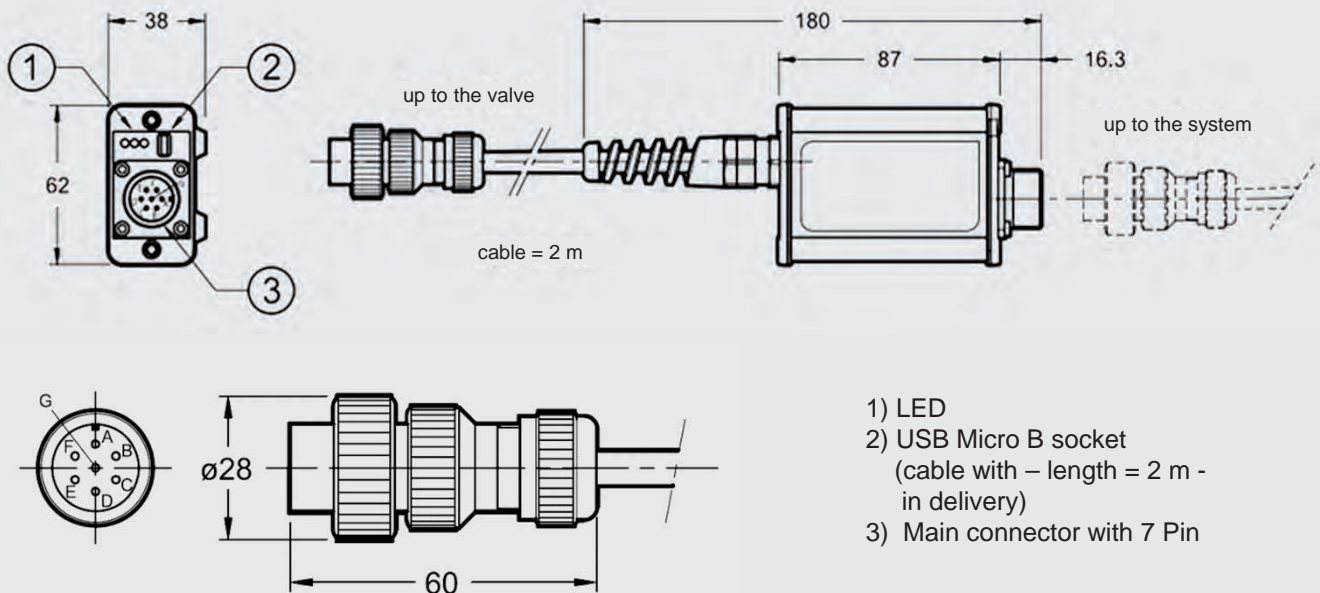

- 1) LED
- 2) USB Micro B socket
(cable with – length = 2 m - in delivery)
- 3) Main connector with 7 Pin

In the casing of electronics, a 7-pole port for connecting with external devices is integrated.

The cable diameter for the main connector (cable and connector are not included in delivery) has to be min. 8 mm and should be max. 10 mm.

Hint

We recommend the use of a metal connector to ensure electromagnetic compatibility (EMC) and to avoid electromagnetic disturbances.

Note

The information in this brochure relates to the operating conditions and applications described. For applications not described, please contact the relevant technical department.
All technical details are subject to change without notice.

HYDAC Fluidtechnik GmbH
Justus-von-Liebig-Str.
D-66280 Sulzbach/Saar
Tel: 0 68 97 /509-01
Fax: 0 68 97 /509-598
E-Mail: valves@hydac.com

4/3 proportional directional valves hydraulic pilot operated P4WEH 10 to 32

DESCRIPTION

The P4WEH is a pilot operated proportional directional valve, which combines directional control with speed control of the consumer.

The controlled volume flow is proportional to the electrical input signal on valve electronics.

According to the input signal, the magnet generates a control pressure, which shifts hydraulically the main piston against a spring. In this process, cross-sections are released, which determine the size of the volume flow depending on the pressure difference.

FEATURES

- High nominal flow due to optimized, cast manifold
- Low hysteresis due to precision machining of moving parts
- Easy interchangeability due to internationally standardised interface ISO 4401

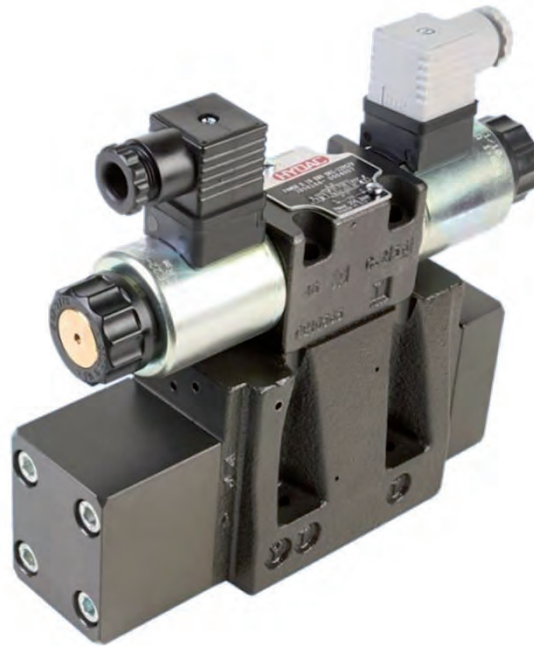

CONTENT

Designation

Features

Model code

Spool types / Symbols

Function

Section view

Accessories

Technical Data

Performance

Dimensions

MODEL CODE

P4WEH E 10 E80 D01-24PG/V/D

Type

Proportional 4 directional valve, electrical / hydraulic

Control type

E = external pilot supply and drain
 EI = external pilot supply, internal pilot drain
 IE = internal pilot supply, external pilot drain
 I = internal pilot supply and drain

Nominal size (NG)

10, 16, 25, 32

Symbols

see chapter „Spool types / Symbols“

Nominal flow (at $\Delta p = 10 \text{ bar } P \rightarrow T$)

80 = 80 l/min
 80/40 = 80 l/min ($P \rightarrow A$ or $A \rightarrow T$) / 40 l/min ($B \rightarrow T$ or $P \rightarrow B$)
 further nominal flows see „Nominal flow ranges“ in chart „Hydraulic specifications“

Series

D01 = standard
 D02 = ISO 4401-05-05-0-05 (NG10 only)

Rated voltage of the solenoid coil

12 = 12 V DC
 24 = 24 V DC

Coil Type

PG = DIN connector to DIN 43563

Sealing material

V = FKM (standard)
 N = NBR

Pressure reducing valve (30 bar fixed)

Necessary if control pressure at port X is higher than 210 bar

SPOOL TYPES / SYMBOLS

Type	Basic symbol	Type	Basic symbol
E		J	
EA		JA	
EB		JB	

FUNCTION

The P4WEH is a hydraulic pilot operated, proportional 4 directional valve. The volume flow is controlled continuously (proportionally) to the electrical input signal at the solenoid coil.

These valves essentially consist of the pilot stage (pressure regulating valve) and the main stage (directional valve). The pilot stage consists of the valve housing (1), a control piston with 2 pressure measuring pins (2) and two proportional solenoids (3).

The main stage consists of the housing (4), a main piston (5) and a centring spring (6) acting in both directions.

The pressure supply of the valve results from the interface according to ISO 4401. The external pilot supply and drain result from port X and Y to the pilot valve. The regulated control pressure is proportional to the stroke of the main stage. If one of the two solenoids is energized, the pilot releases the connection to control port A or B and regulates the control pressure according to the set solenoid current.

The main piston shifts until a balance of force is reached by pressurizing one of the two sides of the main piston via control pressure. The desired connection PABT or PBAT is released.

If the valve is subsequently relieved of pressure, the centring spring returns the main piston to neutral again.

P4WEH valves are available in two different versions, which differ in their interface. Due to this difference, the valve versions are not compatible with each other.

SECTION VIEW

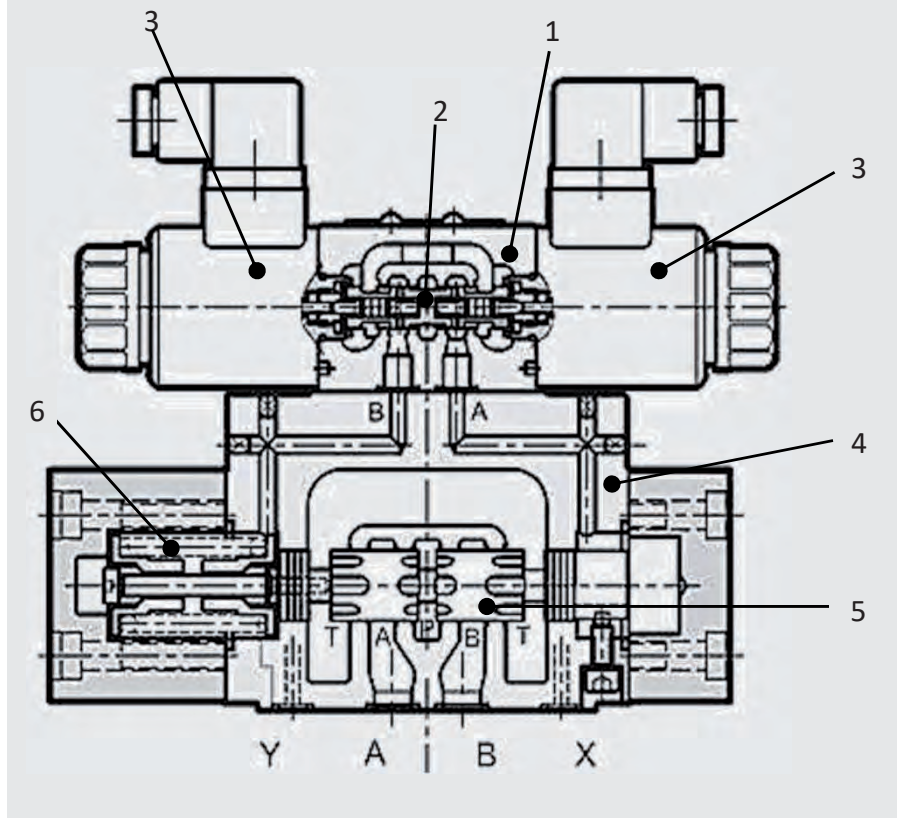

ACCESSORIES

	Designation	Part no.
Seal kits (main stage)	P4WEH 10: 12,42 x 1,78 90 Sh (5 pcs) 9,25 x 1,78 90 Sh (2 pcs)	FKM: 3524523 NBR: 3524475
	P4WEH 16: 22,22 x 2,62 90 Sh (4 pcs) 10,82 x 1,78 90 Sh (2 pcs)	FKM: 3524634 NBR: 3524553
	P4WEH 25: 29,82 x 2,62 90 Sh (4 pcs) 20,24 x 2,62 90 Sh (2 pcs)	FKM: 3524660 NBR: 3524659
	P4WEH 32: 37,59 x 3,53 90 Sh (4 pcs) 20,24 x 2,62 90 Sh (2 pcs)	FKM: 3524690 NBR: 3524685
	Mounting screws	P4WEH 10: ISO 4762 M6 x 35 (4 pcs)
P4WEH 16: ISO 4762 M10 x 60 (4 pcs) ISO 4762 M6 x 60 (2 pcs)		4501973
P4WEH 25: ISO 4762 M12 x 60 (6 pcs)		3524698
P4WEH 32: ISO 4762 M20 x 70 (6 pcs)		3524700
Control module EHCD*	AM005XXXU	6158999

*For further information see brochure "Control modules for hydraulic drives -EHCD" catalogue-24000.2/10/14 or contact customer support EHCD@hydac.com.

TECHNICAL DATA 1

General specifications

	Nominal size			
	10	16	25	32
MTTF _g :	According to EN ISO 13849-1:2015 chart C1 & C2			
Ambient temperature:	[°C] -20 to +60			
Installation position:	No orientation restrictions			
Weight:	[kg] 7,5	9,7	16,0	53,0
Material:	Valve casing: Name plate:			Cast iron Aluminium
Surface coating:	Valve casing:			Phosphate

Hydraulic specifications

	Nominal size				
	10	16	25	32	
Operating pressure:	[bar]	Port P: Port T, internal leak port: Port T, external leak port:			$p_{max} = 350$ $p_{max} = 10$ $p_{max} = 250$
Control pressure:	[bar]	$p_{min} = 30$ $p_{max} = 210$			
Max. nominal flow:	[l/min]	180	450	800	1600
Nominal flow ranges: (at $\Delta p = 10$ bar, $P \rightarrow T$)	[l/min]	80 80/40	100 150 150/75	200 300 300/150	350 500 500/250
Operating fluid:	Hydraulic oil to DIN 51524 part 1, 2 and 3				
Media operating temperature range:	[°C]	-20 to +80			
Viscosity range:	[mm ² /s]	10 – 400			
Permitted contamination level of operating fluid:	class 18/16/13 to ISO 4406				
Sealing material:	NBR, FKM (standard)				
Control flow: (Control 0 → 100 %)	[l/min]	3	5	9	13
Control volume: (Control 0 → 100 %)	[cm ³]	1,7	3,2	9,1	21,6

Electrical specifications

	Nominal size				
	10	16	25	32	
Switching time (0 → 100%):	[ms]	50	80	100	200
Switching time (100% → 0):	[ms]	40	50	70	120
Type of voltage:	DC				
Rated voltage:	[V]	12, 24			
Hysteresis:	[%]	< 4 of Q_{max}			
Repeatability:	[%]	< ±2 of Q_{max}			
Protection class to DIN EN 60529:	with electrical connection "G" IP65 ²				

Hint

If the system pressure exceeds the max. allowable control pressure, it is necessary to use the version with external control and control pressure within the specifications. Otherwise, the valve with internal pilot control and pressure reducing valve as 30 bar fixed sandwich plate can be ordered.

¹ see „Conditions and Instructions for Valves“ in brochure 53.000

² if installed correctly

PERFORMANCE

The performance represent typical curves for the various available valve pistons, at a constant Δp , depending on the current supplied by the solenoid coil.

(Note: The maximum current for the solenoid version D24 is 800 mA).

The total valve pressure drop (Δp) was measured between port P and T of the valve.

Q-I-performance NG10

(measured at 36 cSt, 50°C), symbols E; EA; EB; J; JA; JB, nominal flow 80 l/min

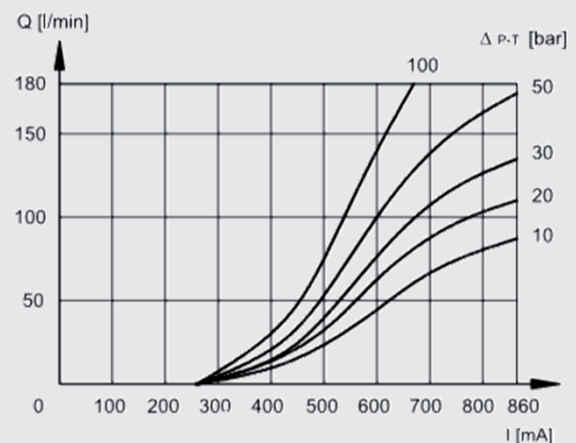

PERFORMANCE

Q-I-performance NG16

(measured at 36 cSt, 50°C), symbols E; EA; EB; J; JA; JB, nominal flow 100 l/min

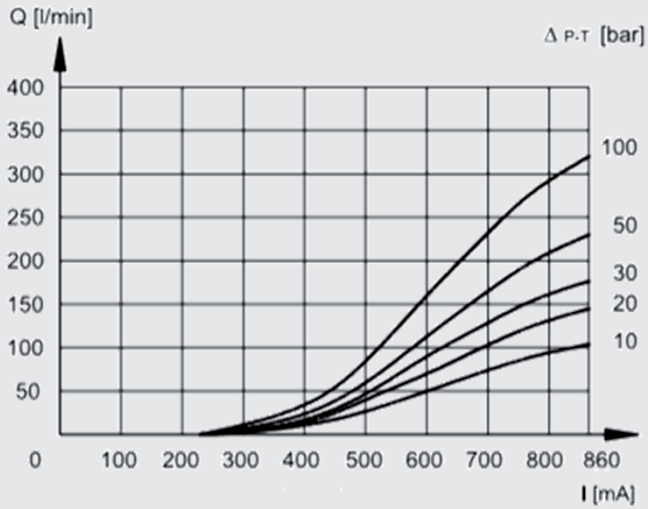

Nominal flow 150 l/min

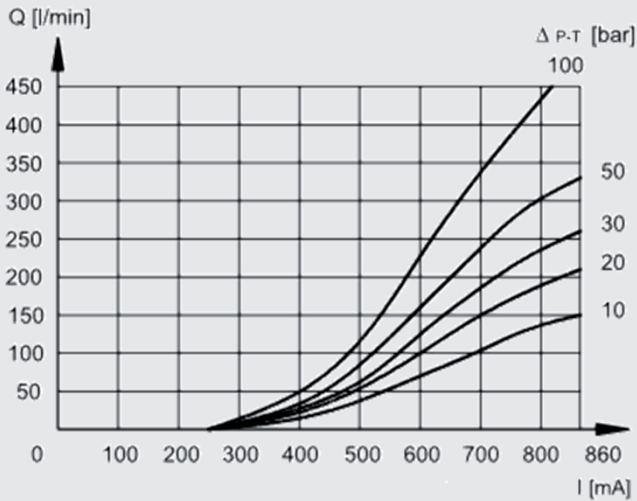

Q-I-performance NG25

(measured at 36 cSt, 50°C), symbols E; EA; EB; J; JA; JB, nominal flow 200 l/min,

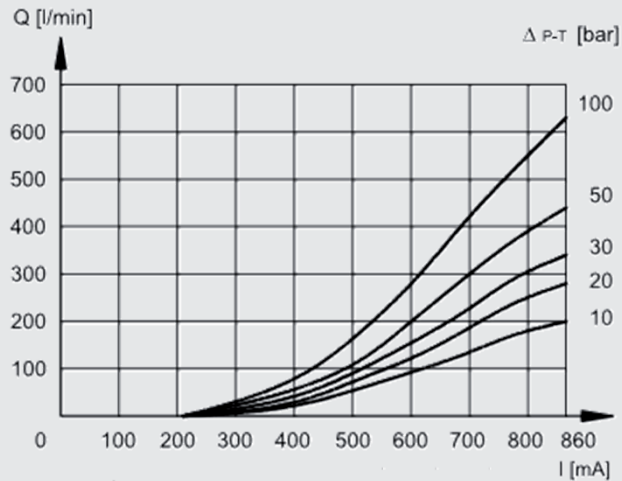

Nominal flow 300 l/min

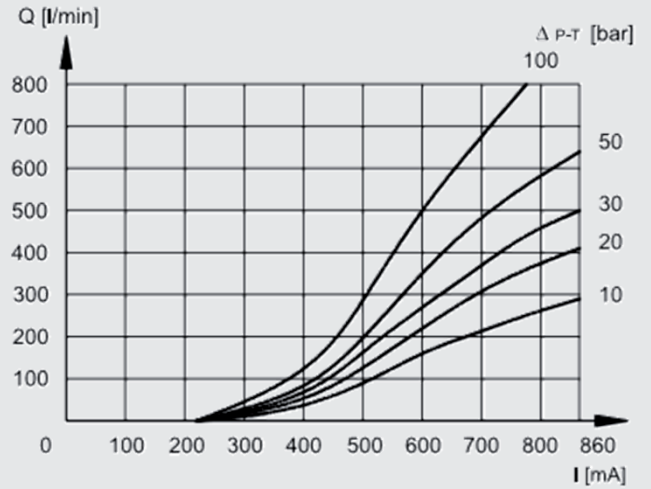

Q-I-performance NG32

(measured at 36 cSt, 50°C), symbols E; EA; EB; J; JA; JB, nominal flow 350 l/min

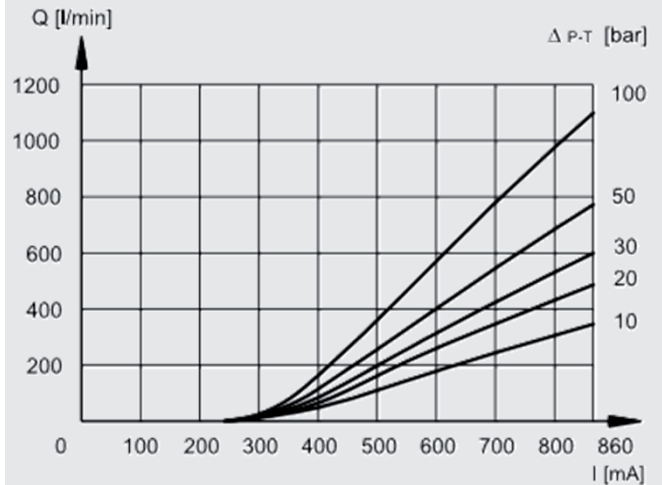

Nominal flow 500 l/min

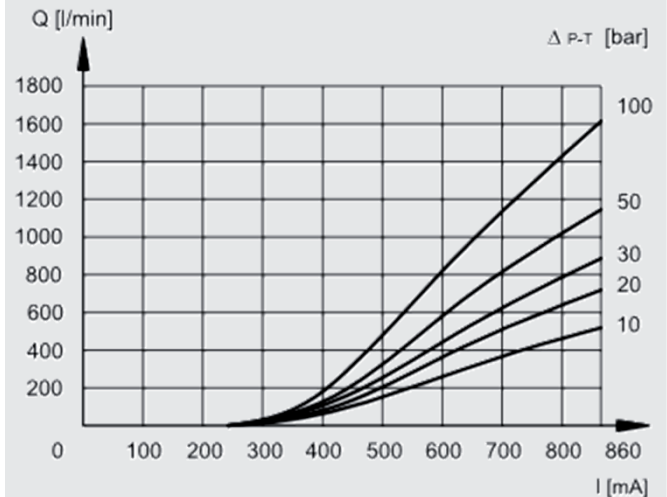

DIMENSIONS NG10

INTERFACE

CETOP 4.2-4 P05-350 (D01)

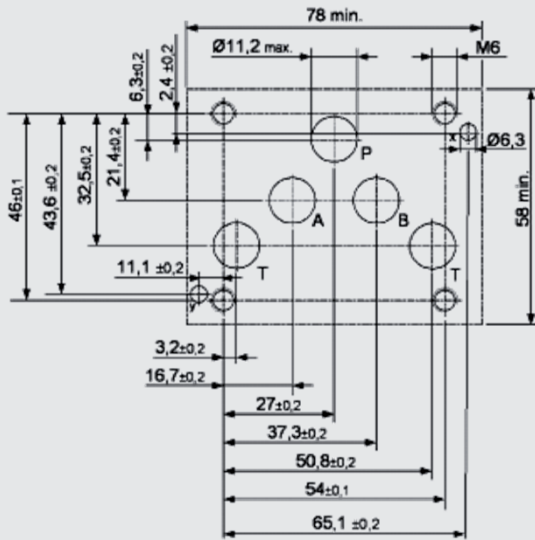

INTERFACE

ISO 4401-05-05-0-05 (D02)
(CETOP 4.2-4 R05-350)

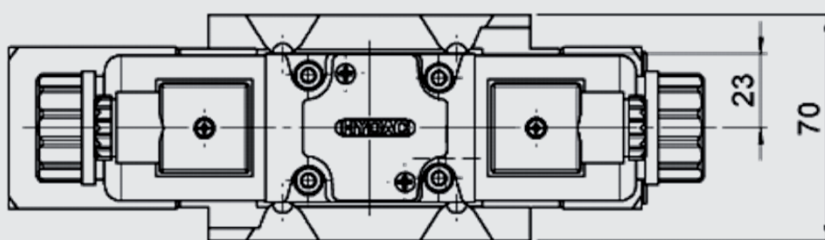
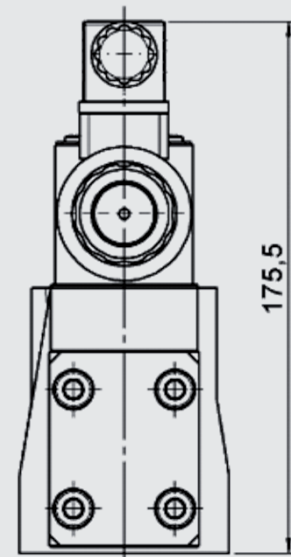
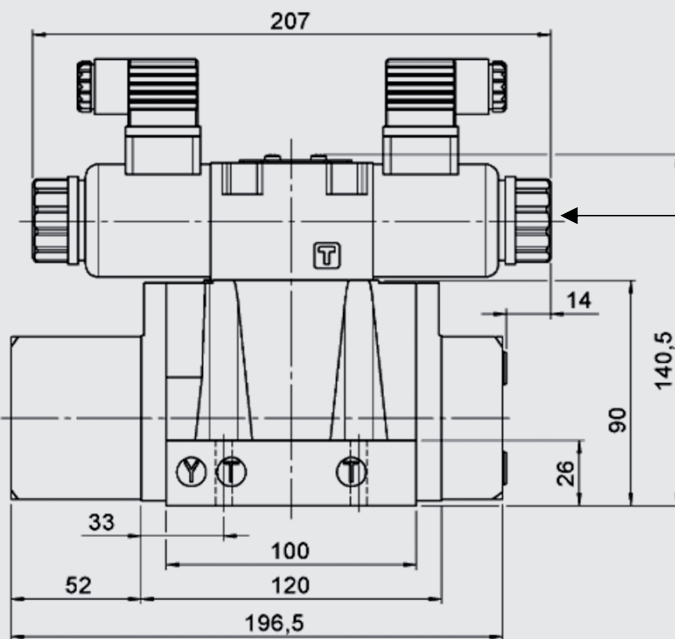
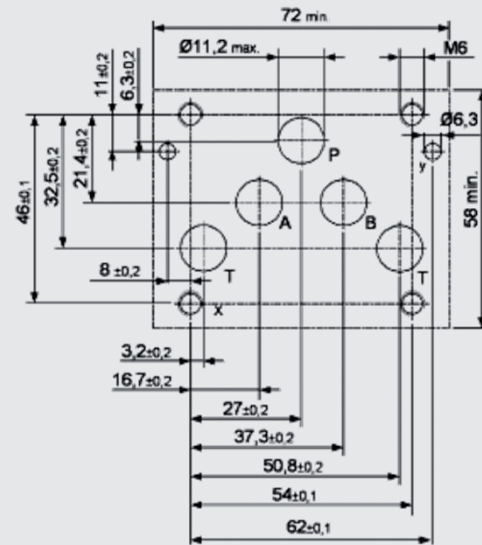

Hint

When using the pressure reducing as sandwich plate, the installation height changes by 40 mm to 180.5 mm.

Mounting screws (ISO 4762): 4 pcs M6 x 35 A8.8 (not included in delivery)
Torque: 8 Nm

DIMENSIONS NG25

INTERFACE

ISO 4401-08-08-0-05 (D01)
(CETOP 4.2-4-08-350)

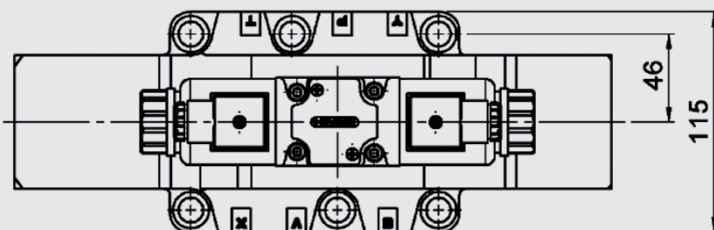
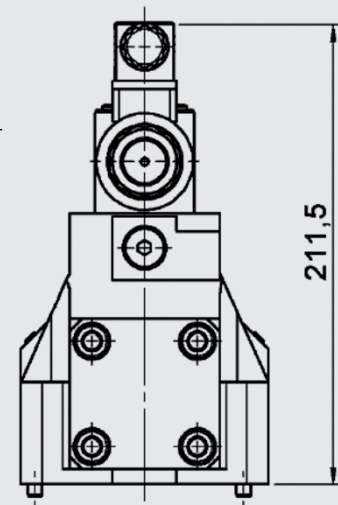
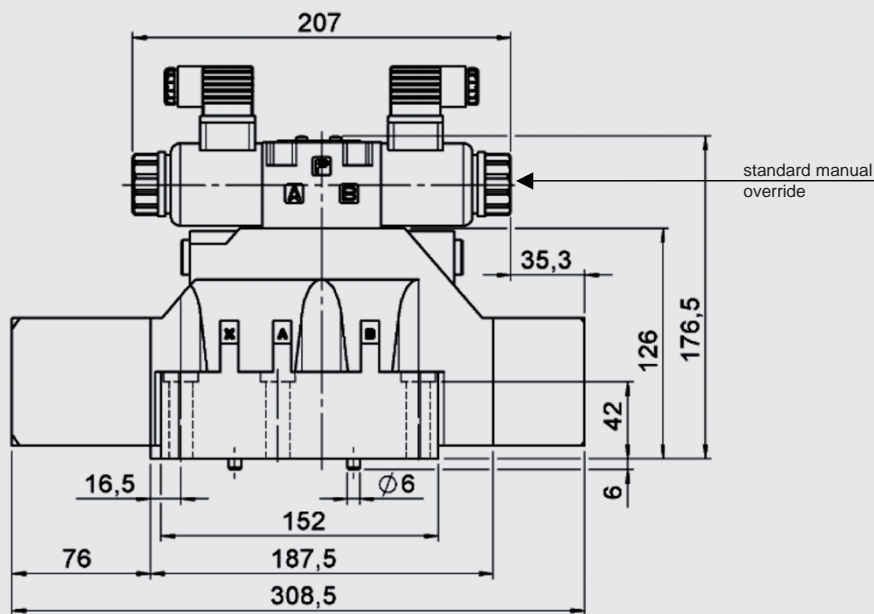
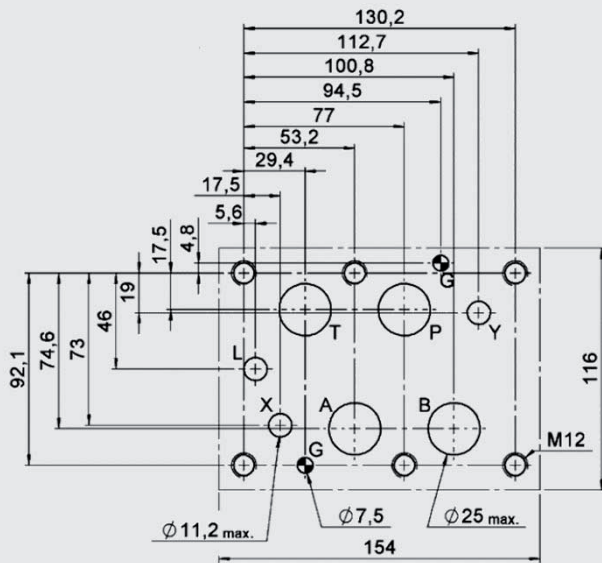

Hint

When using the pressure reducing as sandwich plate, the installation height changes by 40 mm to 216.5 mm.

Mounting screws (ISO4762): 6 pcs M12x60 A8.8 (not included in delivery)
Torque: 69 Nm

Plug

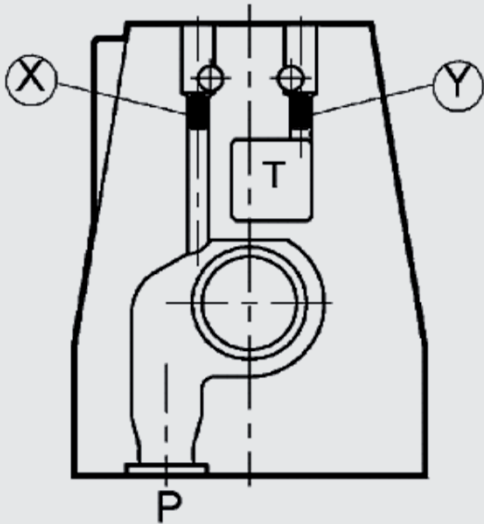

Control type		Installation	
		X	Y
E	external pilot supply and drain	●	●
EI	external pilot supply, internal pilot drain	●	-
IE	internal pilot supply, external pilot drain	-	●
I	internal pilot supply and drain	-	-

- **Version „E“ –**
Pilot oil supply is external from a separate fluid power supply via port X.
The pilot oil drain is also external via port Y.
- **Version „EI“ –**
Pilot oil supply is external from a separate fluid power supply via port X.
The pilot oil drain is internal via port T.
- **Version „IE“ –**
Pilot oil supply is internal via port P.
The pilot oil drain is external via port Y.
- **Version „I“ –**
Pilot oil supply is internal via port P.
The pilot oil drain is internal via port T.

The valve is configured and delivered as required.
The threaded plugs are glued in at delivery.
Subsequent modification is not possible.

Note

The information in this brochure relates to the operating conditions and applications described. For applications not described, please contact the relevant technical department. All technical details are subject to change without notice.

HYDAC Fluidtechnik GmbH
Justus-von-Liebig-Str.
D-66280 Sulzbach/Saar
Tel: 0 68 97 /509-01
Fax: 0 68 97 /509-598
E-Mail: valves@hydac.com

4/3 proportional directional valves hydraulic pilot operated with Onboard Electronic P4WEHE 10 to 32

DESCRIPTION

The P4WEHE is a pilot operated proportional directional valve with integrated Onboard Electronic, which combines directional control with speed control of the consumer.

The controlled volume flow is proportional to the electrical input signal on valve electronics.

According to the input signal, the magnet generates a control pressure, which shifts hydraulically the main piston against a spring. In this process, cross-sections are released, which determine the size of the volume flow depending on the pressure difference.

The integrated digital electronics allows improved performance and function due to

- shorter response times
- reduced hysteresis
- better repeatability

FEATURES

- High flow capacity due to optimized, cast casing
- Low hysteresis due to precision machining of moving parts
- The pilot supply or pilot drain can be internal or external
- The control results directly from the integrated Onboard electronic
- Easy interchangeability due to internationally standardised interface according to ISO 4401

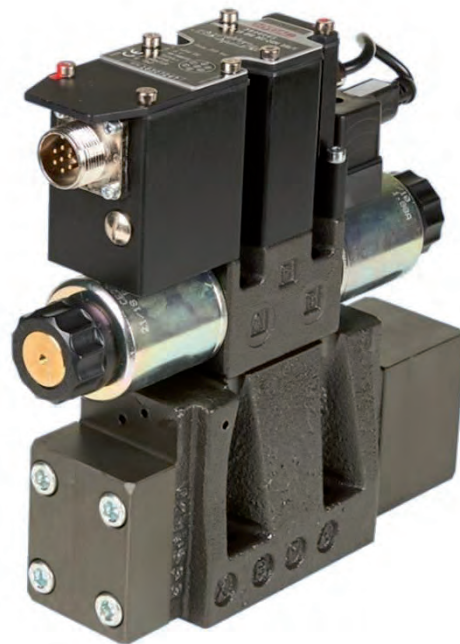

CONTENT

Description
Features
Model code
Spool types / Symbols
Technical Data
Function
Section view
Accessories
Performance
Dimensions
Electronic

MODEL CODE

P4WEHE E 10 E80 D01-24PG E0B/V/D

Type

Proportional 4 directional valve, electrical / hydraulic with Onboard Electronic

Control type

E = external pilot supply and drain
EI = external pilot supply, internal pilot drain
IE = internal pilot supply, external pilot drain
I = internal pilot supply and drain

Nominal size (NG)

10, 16, 25, 32

Symbols

see chapter „Spool types / Symbols“

Nominal flow (at $\Delta p = 10$ bar, P – T)

80 = 80 l/min
80/40 = 80 l/min (P → A or A → T) / 40 l/min (B → T or P → B)
further nominal flows „Nominal flow ranges“
in chart „Hydraulic specifications“

Series

D01 = standard
D02 = ISO 4401-05-05-0-05 (NG10 only)

Rated voltage of the solenoid coil

24 = 24 V DC

Coil Type

PG = 7-pin MIL-C-5015-G (DIN-EN 175201-804)

Input signal

E0 = ± 10 V
E1 = 4 – 20 mA

Pin C Function

see „Diagramms Pin C Function“ in chapter „Electronic“

Sealing material

V = FKM (standard)
N = NBR

Pressure reducing valve (30 bar fixed)

Necessary if control pressure at port X is higher than 210 bar

SPOOL TYPES / SYMBOLS

Type	Basic symbol	Type	Basic symbol
E		J	
EA		JA	

TECHNICAL DATA ¹

General specifications

	Nominal size			
	10	16	25	32
MTTF _d :	According to EN ISO 13849-1:2015 chart C1 & C2			
Ambient temperature:	[°C] -20 to +60			
Installation position:	No orientation restrictions			
Weight:	[kg] 7,9	10,1	16,4	53,3
Material:	Valve casing:			Cast iron
	Name plate:			Aluminium
Surface coating:	Valve casing:			Phosphate

Hydraulic specifications

	Nominal size				
	10	16	25	32	
Operating pressure:	[bar]	Port P: p _{max} = 350 Port T, internal leak port: p _{max} = 10 Port T, external leak port: p _{max} = 250			
Control pressure:	[bar]	p _{min} = 30 p _{max} = 210			
Max. nominal flow:	[l/min]	180	450	800	1600
Nominal flow ranges:	[l/min]	80	100	200	350
(at Δp = 10 bar, P → T)		80/40	150	300	500
			150/75	300/150	500/250
Operating fluid:	Hydraulic oil to DIN 51524 part 1, 2 and 3				
Media operating temperature range:	[°C]	-20 to +80			
Viscosity range:	[mm ² /s]	10 – 400			
Permitted contamination level of operating fluid:	class 18/16/13 to ISO 4406				
Sealing material:	NBR, FKM (standard)				
Control flow:	[l/min]	3,5	4,1	9,2	13,7
(Control 0 → 100 %)					
Control volume:	[cm ³]	1,7	3,2	9,1	21,6
(Control 0 → 100 %)					

Electrical specifications

	Nominal size				
	10	16	25	32	
Switching time (0 → 100%):	[ms]	50	80	100	200
Switching time (100% → 0):	[ms]	40	50	70	120
Type of voltage:	DC				
Rated voltage:	[V]	12, 24			
Hysteresis:	[%]	< 4 of Q _{max}			
Repeatability:	[%]	< ±2 of Q _{max}			
Protection class to DIN EN 60529:	with electrical connection "G" IP65 ²				

Hint

If the system pressure exceeds the max. allowable control pressure, it is necessary to use the version with external control and control pressure within the specifications. Otherwise, the valve with internal pilot control and pressure reducing valve as 30 bar fixed sandwich plate can be ordered.

¹ see „Conditions and Instructions for Valves“ in brochure 53.000

² if installed correctly

FUNCTION

The P4WEHE is a hydraulic pilot operated, proportional 4 directional valve. The volume flow is controlled continuously (proportionally) to the electrical input signal at the solenoid coil.

These valves essentially consist of the pilot stage (pressure regulating valve) and the main stage (directional valve). The pilot stage consists of the valve housing (1), a control piston with 2 pressure measuring pins (2) and two proportional solenoids (3). The proportional solenoid coils are controlled via the integrated Onboard electronic (7). OBE and pilot stage are connected via the main connector (8).

The main stage consists of the housing (4), a main piston (5) and a centring spring (6) acting in both directions.

The pressure supply of the valve results from the interface according to ISO 4401. The external pilot supply and drain result from port X and Y to the pilot valve. The regulated control pressure is proportional to the stroke of the main stage. If one of the two solenoids is energized, the pilot releases the connection to control port A or B and regulates the control pressure according to the set solenoid current.

The main piston shifts until a balance of force is reached by pressurizing one of the two sides of the main piston via control pressure. The desired connection PABT or PBAT is released.

If the valve is subsequently relieved of pressure, the centring spring returns the main piston to neutral again.

P4WEH valves are available in two different versions, which differ in their interface. Due to this difference, the valve versions are not compatible with each other.

SECTION VIEW

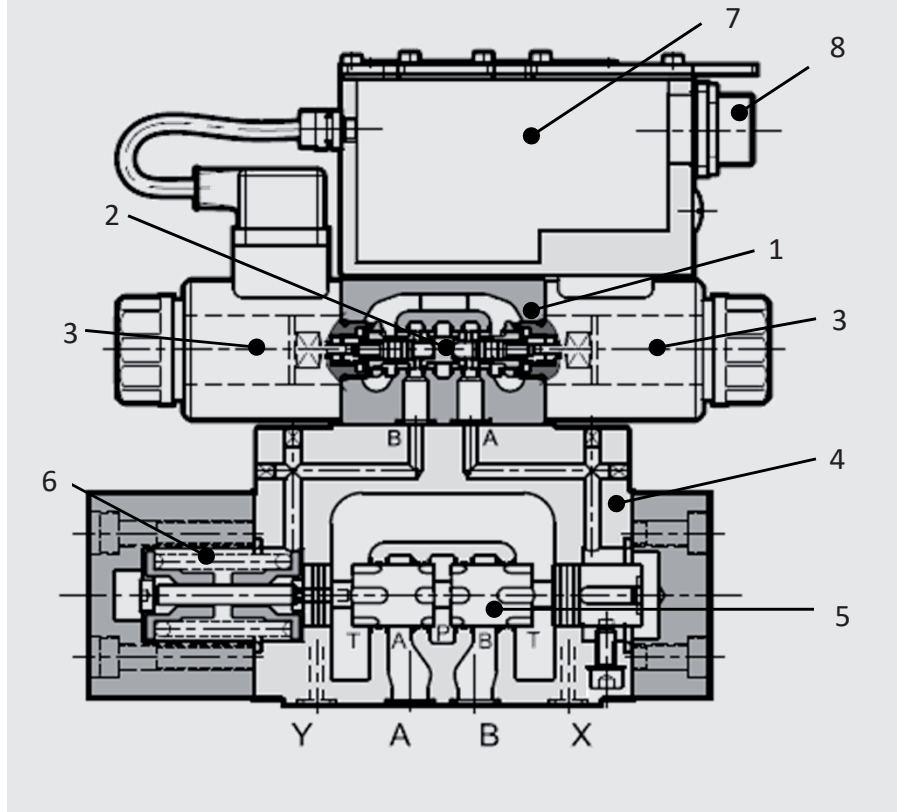

ACCESSORIES

	Designation	Part no.
Seal kits (main stage)	P4WEHE 10: 12,42 x 1,78 90 Sh (5 pcs) 9,25 x 1,78 90 Sh (2 pcs)	FKM: 3524523 NBR: 3524475
	P4WEHE 16: 22,22 x 2,62 90 Sh (4 pcs) 10,82 x 1,78 90 Sh (2 pcs)	FKM: 3524634 NBR: 3524553
	P4WEHE 25: 29,82 x 2,62 90 Sh (4 pcs) 20,24 x 2,62 90 Sh (2 pcs)	FKM: 3524660 NBR: 3524659
	P4WEHE 32: 37,59 x 3,53 90 Sh (4 pcs) 20,24 x 2,62 90 Sh (2 pcs)	FKM: 3524690 NBR: 3524685
Mounting screws	P4WEHE 10: ISO 4762 M6 x 35 (4 pcs)	3524691
	P4WEHE 16: ISO 4762 M10 x 60 (4 pcs) ISO 4762 M6 x 60 (2 pcs)	4501973
	P4WEHE 25: ISO 4762 M12 x 60 (6 pcs)	3524698
	P4WEHE 32: ISO 4762 M20 x 70 (6 pcs)	3524700
Main connector	6+PE EN175201 Part 804	6080324
Electronic	Lin-Bus Interface	3648934

PERFORMANCE

The performance represent typical curves for the various available valve pistons, at a constant Δp , depending on the current supplied by the solenoid coil.

(Note: The maximum current for the solenoid version D24 is 800 mA).

The total valve pressure drop (Δp) was measured between port P and T of the valve.

Q-I-Performance NG10

(measured at 36 cSt, 50°C), symbols E; EA; EB; J; JA; JB, nominal flow 80 l/min

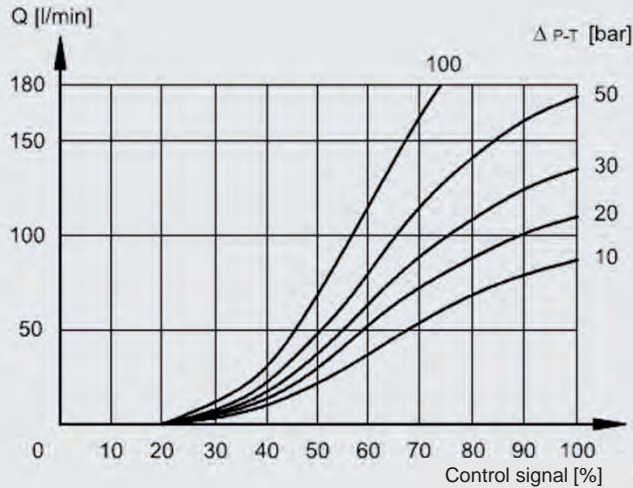

Q-I-Performance NG16

(measured at 36 cSt, 50°C), symbols E; EA; EB; J; JA; JB, nominal flow 100 l/min

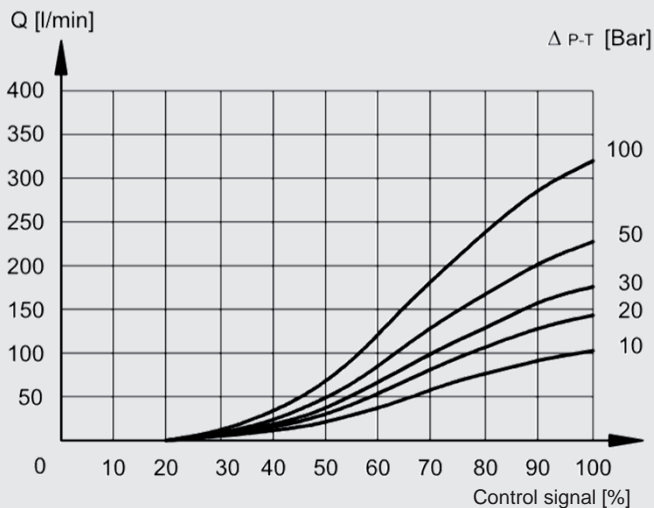

Nominal flow 150 l/min

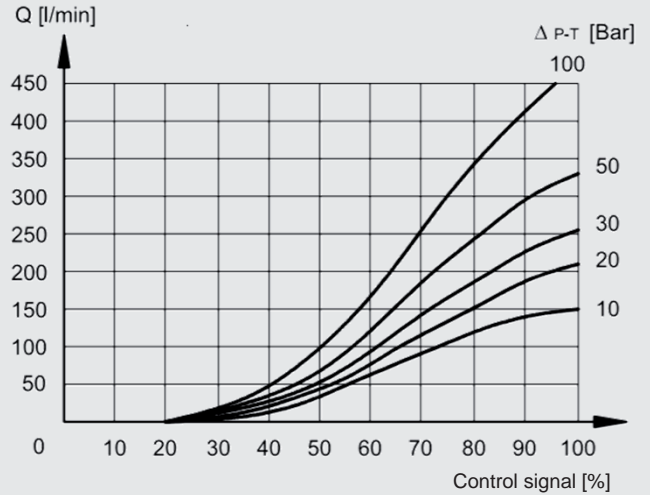

Q-I-Performance NG25

(measured at 36 cSt, 50°C), symbols E; EA; EB; J; JA; JB, nominal flow 200 l/min

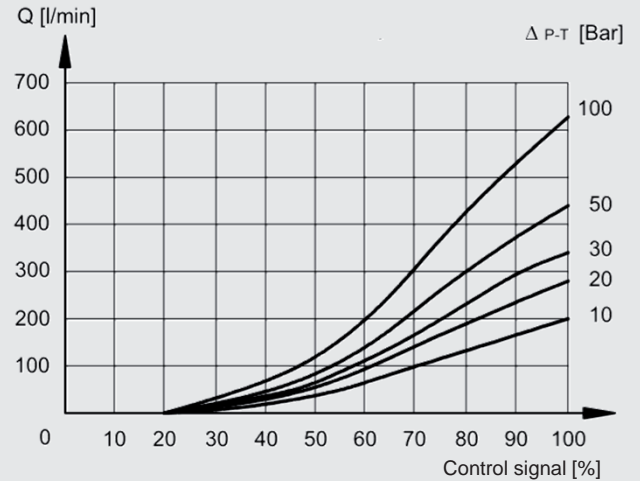

Nominal flow 300 l/min

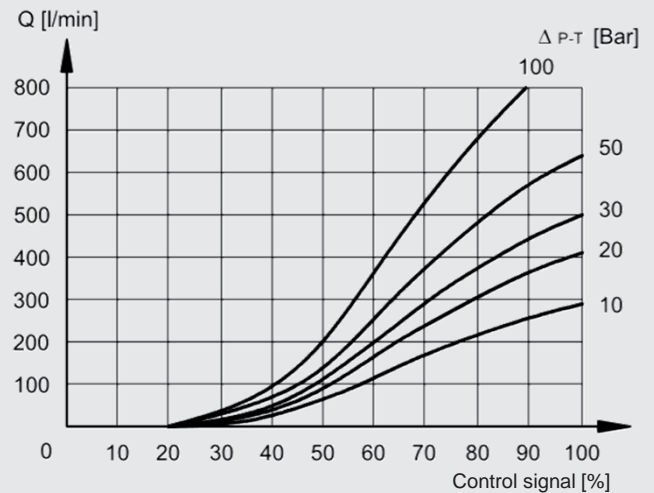

PERFORMANCE

Q-I-Performance NG32

(measured at 36 cSt, 50°C), symbols E; EA; EB; J; JA; JB, nominal flow 350 l/min

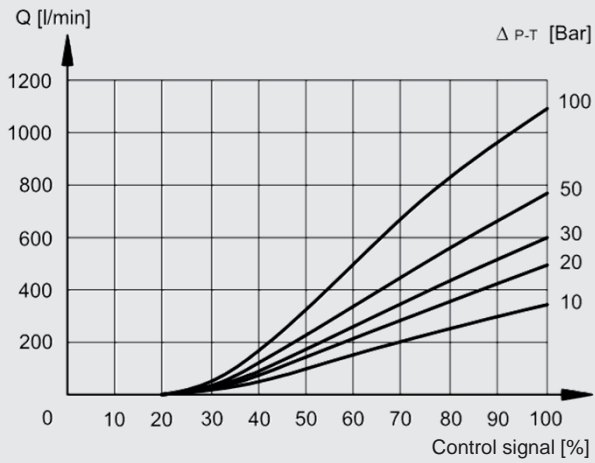

Nominal flow 500 l/min

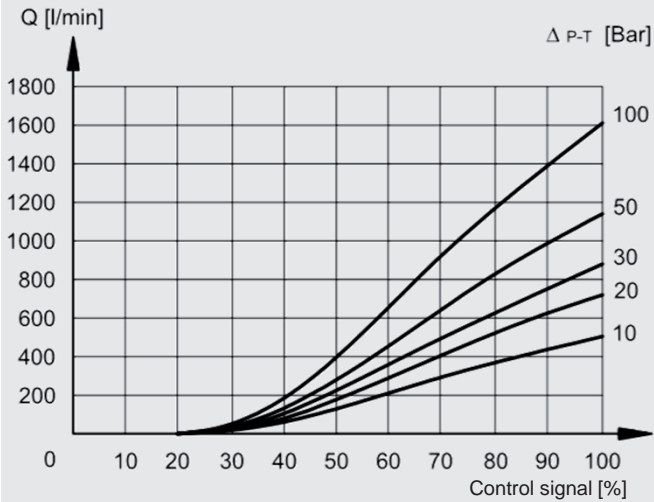

Switching time

(measured at 36 cSt, 50°C)
symbols E, EA, EB, J, JA, JB

NG10

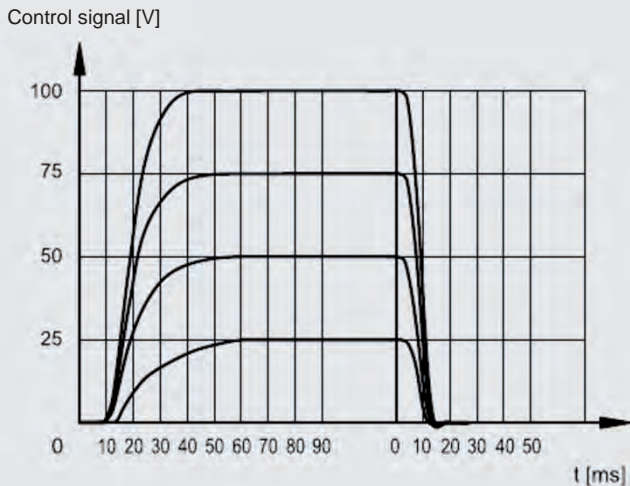

NG16

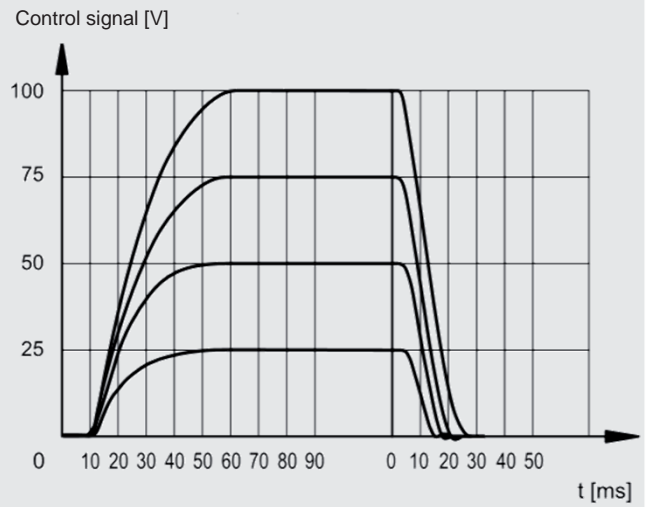

NG25

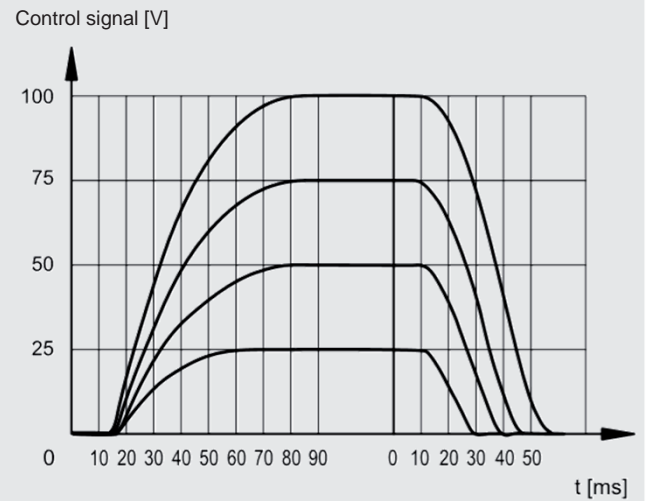

NG32

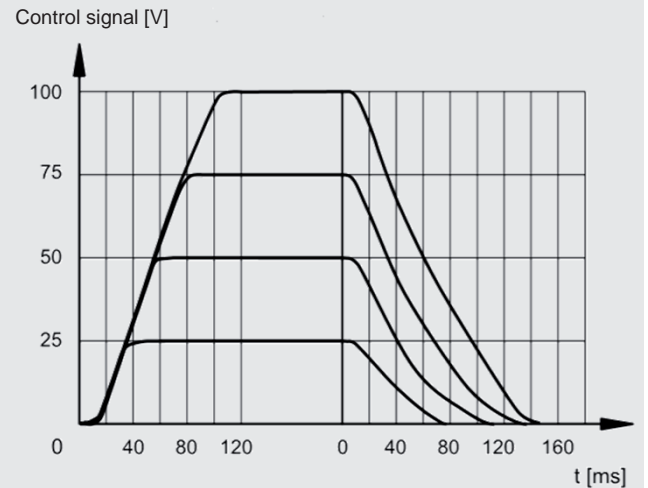

DIMENSIONS NG10

INTERFACE

CETOP 4.2-4 P05-350 (D01)

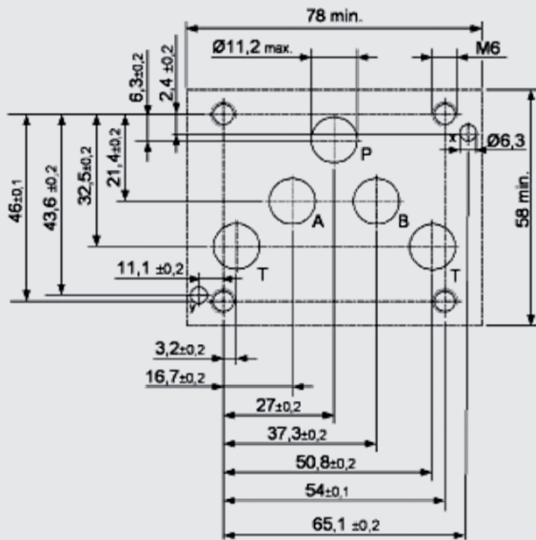

INTERFACE

ISO 4401-05-05-0-05 (D02)

(CETOP 4.2-4 R05-350)

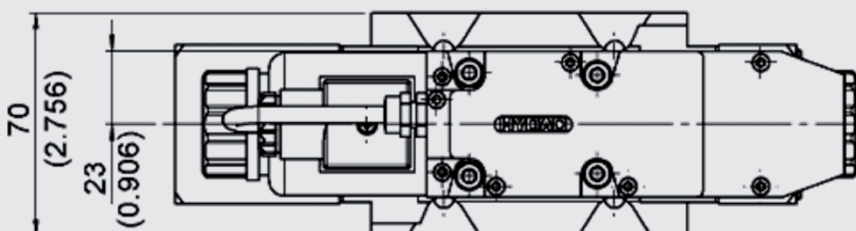
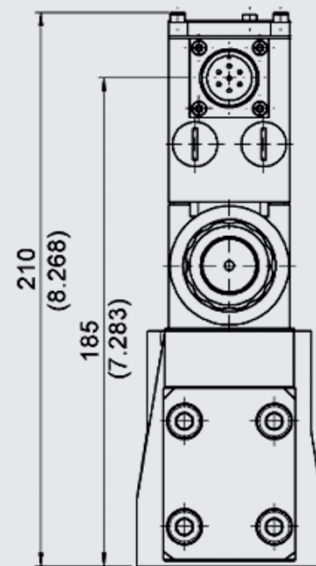
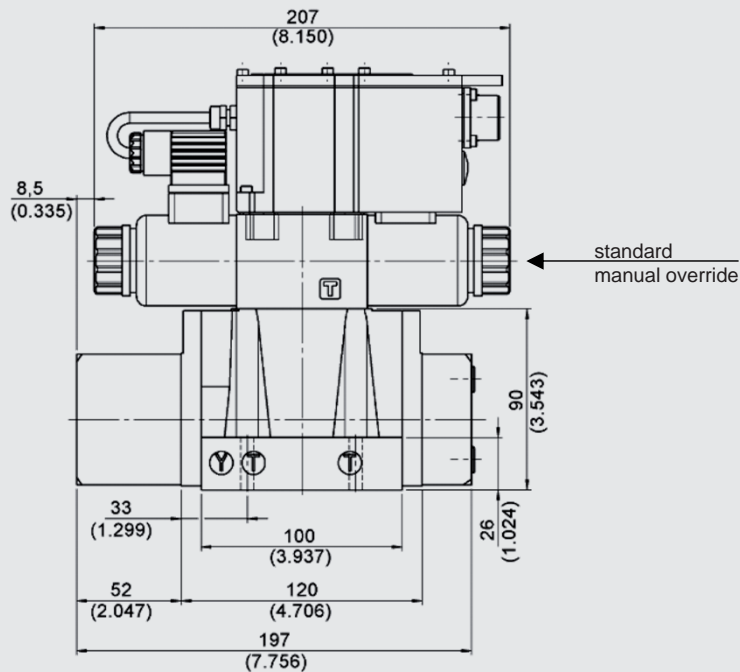
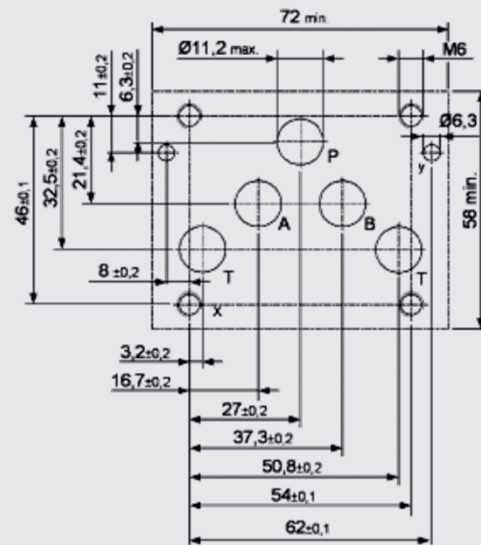

Hint

When using the pressure reducing as sandwich plate, the installation height changes by 40 mm to 250 mm.

Mounting screws (ISO 4762): 4 pcs M6 x 35 A8.8 (not included in delivery)
Torque: 8 Nm

DIMENSIONS NG16

INTERFACE

ISO 4401-07-07-0-05 (D01)
(CETOP 4.2-4-07-350)

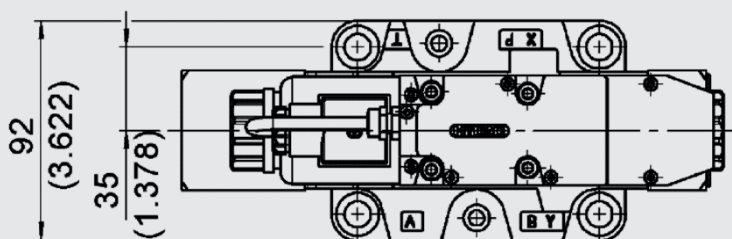
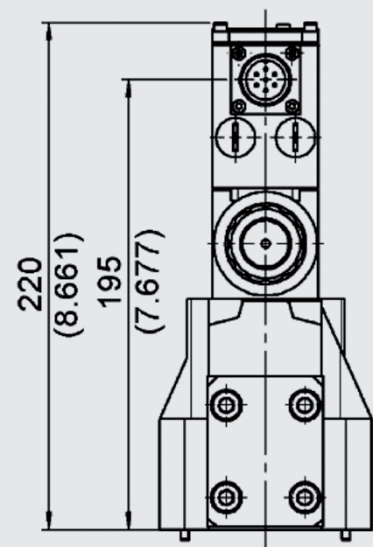
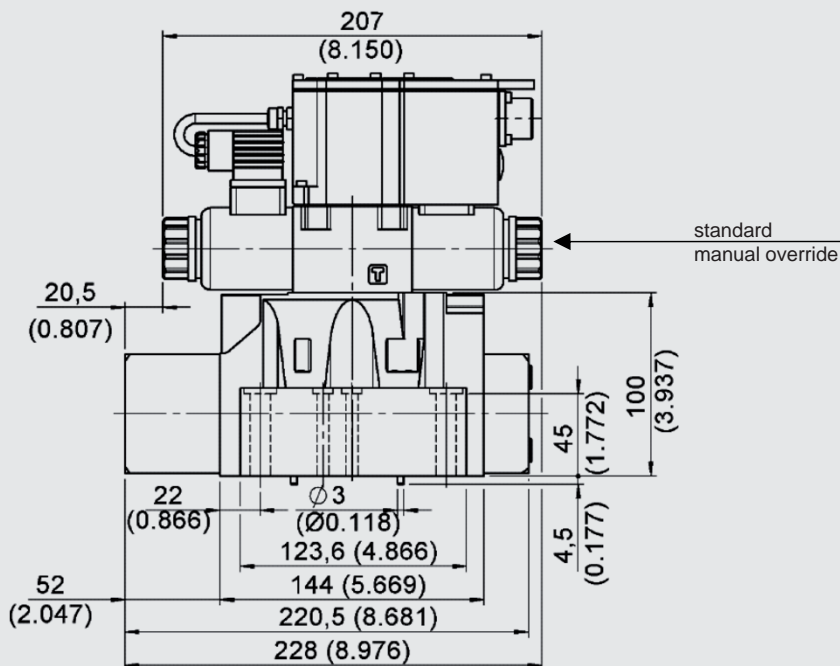
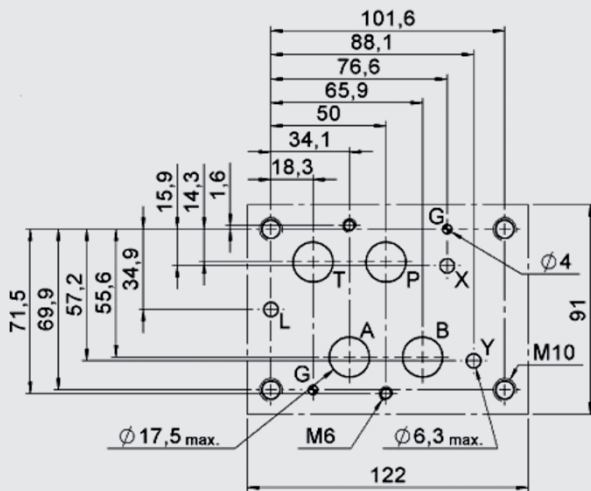

Hint

When using the pressure reducing as sandwich plate, the installation height changes by 40 mm to 260 mm.

Mounting screws (ISO4762): 4 pcs M10x60 A8.8 (not included in delivery)
2 pcs M6 x 60 A8.8 (not included in delivery)

Torque: M10: 40 Nm
M6: 8 Nm

DIMENSIONS NG25

INTERFACE

ISO 4401-08-08-0-05 (D01)
(CETOP 4.2-4-08-350)

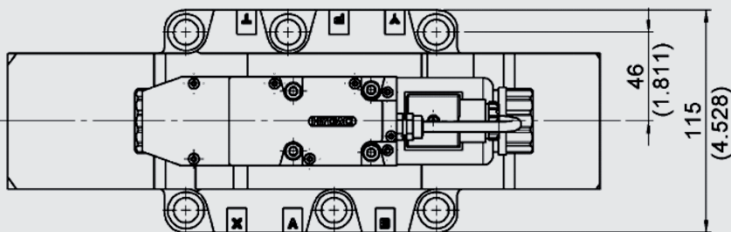
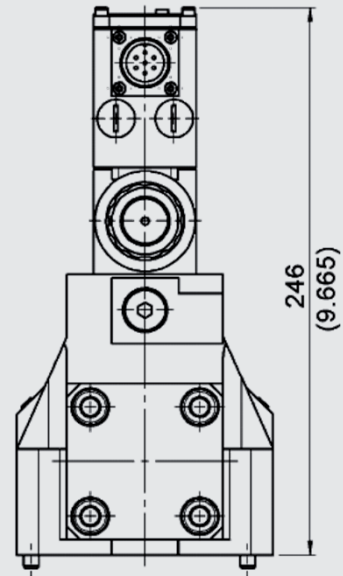
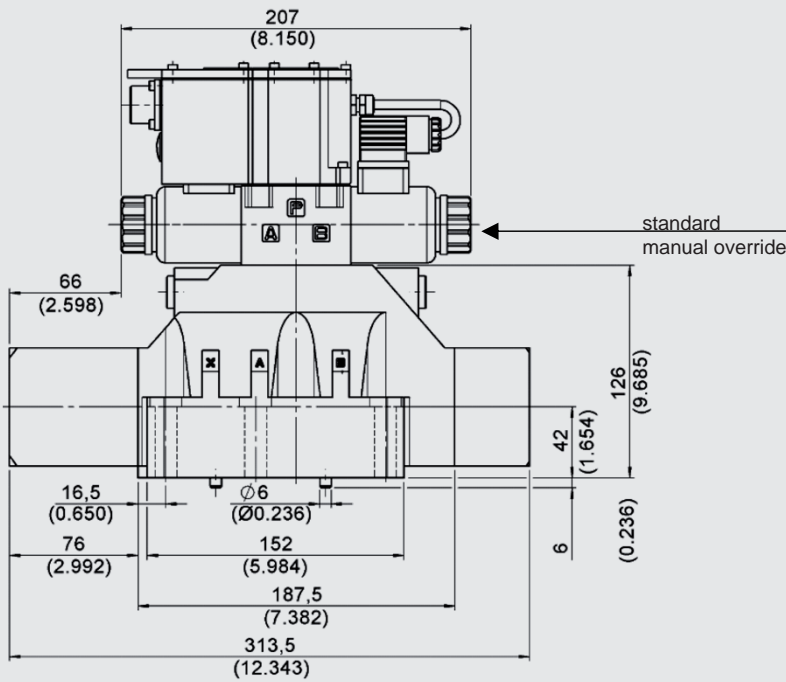
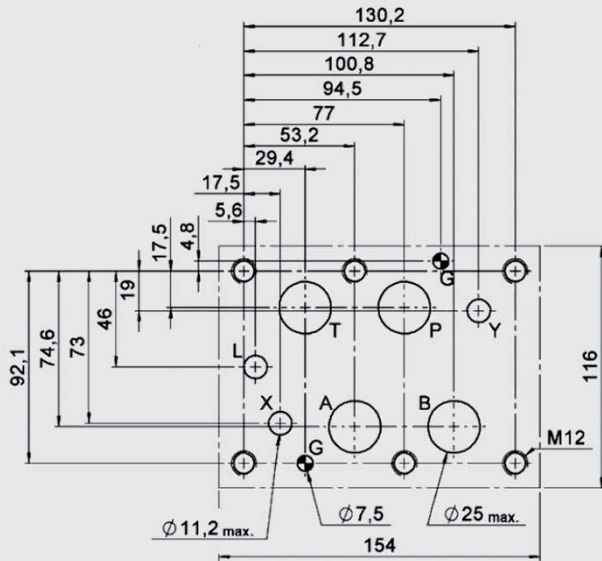

Hint

When using the pressure reducing as sandwich plate, the installation height changes by 40mm to 286 mm.

Mounting screws (ISO4762): 6 pcs M12x60 A8.8 (not included in delivery)
Torque: 69 Nm

DIMENSIONS NG32

INTERFACE

ISO 4401-10-09-0-05 (D01)
(CETOP 4.2-4-10-350)

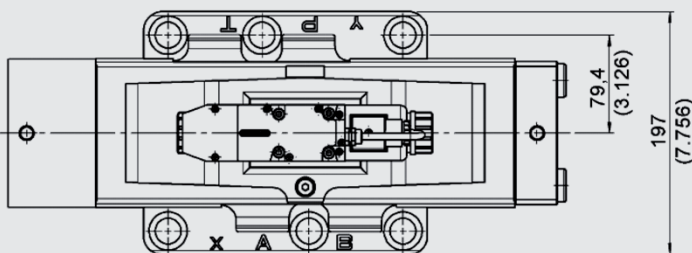
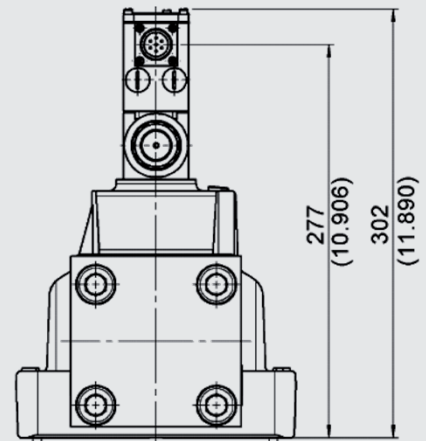
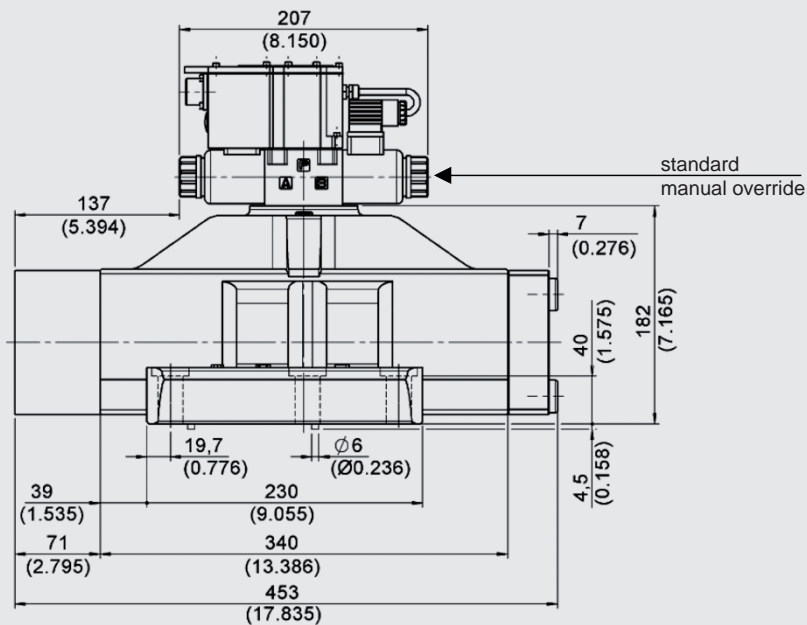
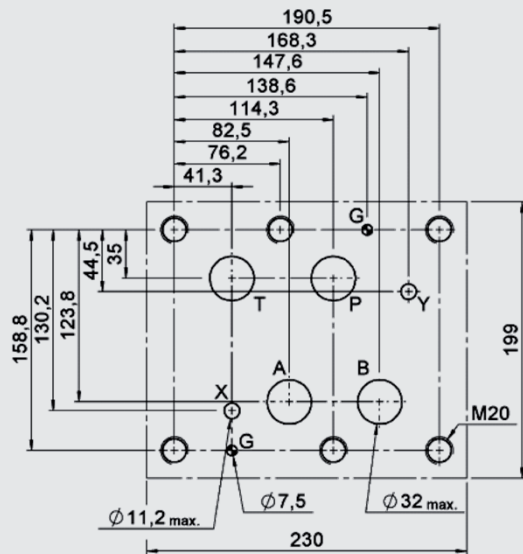

Hint

When using the pressure reducing as sandwich plate, the installation height changes by 40 mm to 342 mm.

Mounting screws (ISO4762): 6 pcs M20x70 A8.8 (not included in delivery)
Torque: 330 Nm

Plug

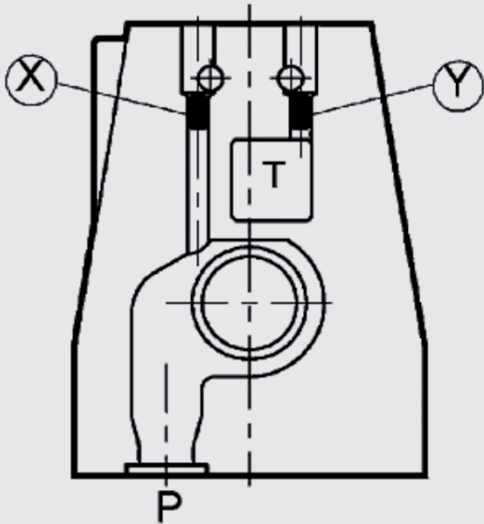

Control type		Installation	
		X	Y
E	external pilot supply and drain	●	●
EI	external pilot supply, internal pilot drain	●	-
IE	internal pilot supply, external pilot drain	-	●
I	internal pilot supply and drain	-	-

- **Version „E“ –**
Pilot oil supply is external from a separate fluid power supply via port X.
The pilot oil drain is also external via port Y.
- **Version „EI“ –**
Pilot oil supply is external from a separate fluid power supply via port X.
The pilot oil drain is internal via port T.
- **Version „IE“ –**
Pilot oil supply is internal via port P.
The pilot oil drain is external via port Y.
- **Version „I“ –**
Pilot oil supply is internal via port P.
The pilot oil drain is internal via port T.

The valve is configured and delivered as required.
The threaded plugs are glued in at delivery.
Subsequent modification is not possible.

INTEGRATED ELECTRONIC

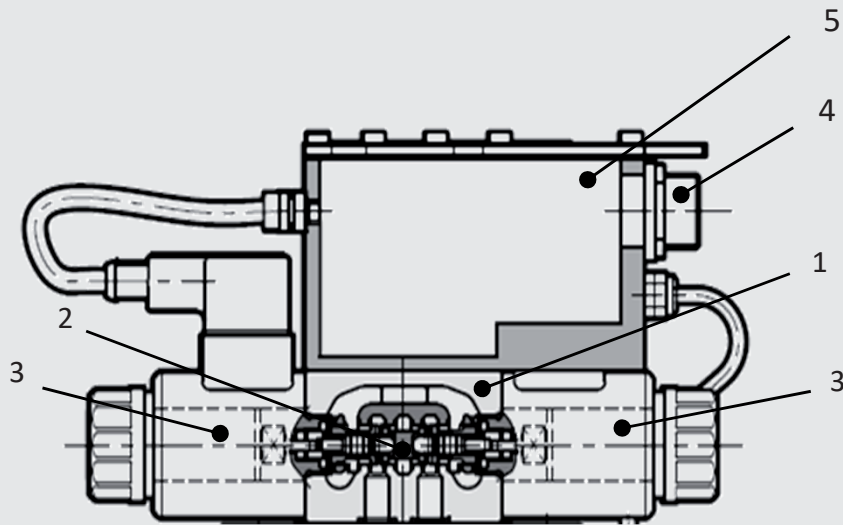

Parameterisable only via LIN bus

- 1) Valve with proportional solenoids
- 2) Valve piston
- 3) Proportional solenoid
- 4) Main connector
- 5) Electronic housing

General specifications

Power consumption:	25 W
Current consumption:	max. 1,88 A
Rated voltage:	24 V DC (19 – 30 V DC, ripple max. 3 Vpp)
Duty cycle:	100% ED (continuous)
Control signal E0:	Voltage signal ± 10 VDC
Control signal E1:	Current signal 4 – 20 mA
Alert signale:	Overload and overheating of electronics
Communication:	LIN-Bus ISO 11898 LIN-Bus Interface
Electronical connection:	7-pin MIL-C-5015-G (DIN-EN 175201-804)
LIN-Bus connection:	M12-IEC 60947-5-2
EMC EN61000-6-4:	According to 2014/30/EU standard
EMC EN61000-6-2:	According to 2014/30/EU standard
Type of protection:	IP65 / IP67 (CEI EN 60529 standard)

ELECTRONIC

Standard version with reference signal voltage E0

PIN	Value	Version A	Version B	Version C
A	24 V DC	Supply voltage		
B	0 V			
C		release 24 V DC	unoccupied	PIN F reference 0 V
D	+/- 10 V	control (differential input)		
E	0 V	PIN D reference		
F	+/- 10 V	monitor (0V reference PIN B)		monitor
PE	GND	earth (mass)		

Standard version with reference signal current E1

PIN	Value	Version A	Version B	Version C
A	24 V DC	Supply voltage		
B	0 V			
C		release 24 V DC	unoccupied	PIN F reference 0 V
D	4 - 20 mA	control		
E	0 V	PIN D reference		
F	4 - 20 mA	monitor (input signal) (0V reference PIN B)		monitor (input signal)
PE	GND	earth (mass)		

Diagramms PIN C Function

Version A: External release (on request)

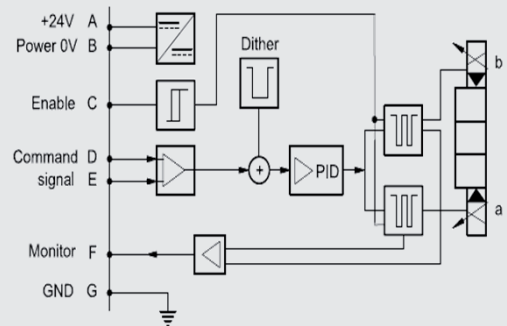

Version B: Internal release (standard)

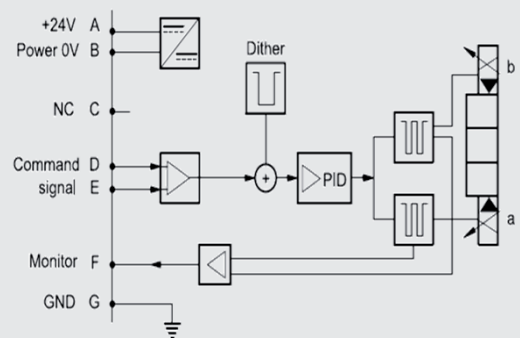

Version C: 0V Monitor (on request)

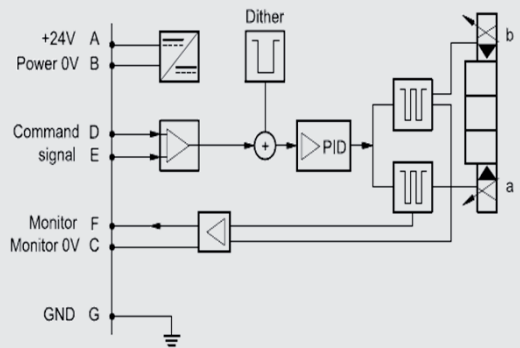

Hint 1

- Voltage signal (0V centring position)
 - -10V to 0 V: flow direction P – B and A – T
 - 0V to +10V: flow direction P – A und B – T
- Current signal (12 mA centring position)
 - 4 mA to 12 mA: flow direction P – B and A – T
 - 12 mA to 20 mA: flow direction P – A and B – T
- With one solenoid (type EA and JA)
 - 4 mA to 20 mA: flow direction P – B and A – T
 - 0V to +10V: flow direction P – B and A – T

Pin D and Pin E must always be contacted.

Hint 2

PIN C function A and B: Nominal input value measured between pin F and pin B.

Hint 3

We recommend to provide an external protection at pin A (24 V DC) for protection of the electronics: 5A/50V fast fuse.

LIN-BUS INTERFACE

Is also required for parameterisation of Onboard electronic.

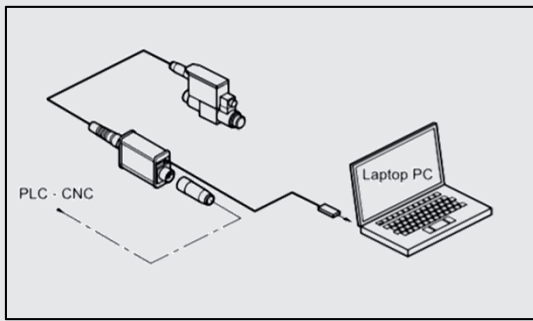

Content*: Parameterize-software, adapter and PC connection cable

- The kit contains a test device with embedded connection cable 7 pin and a USB cable for connection to the PC. The dedicated software are available for download from our website.
- The device is suitable for troubleshooting and functional testing of HYDAC proportional valves with LIN-bus interface.
- The software allow the check of settings, display the diagnostic and permit to make changes on the standard parameter setting made in factory, adapting it to your system.
- No additional power supply is required: the device uses the supply source from the 7 PIN system cable.

* On request (not included in delivery)

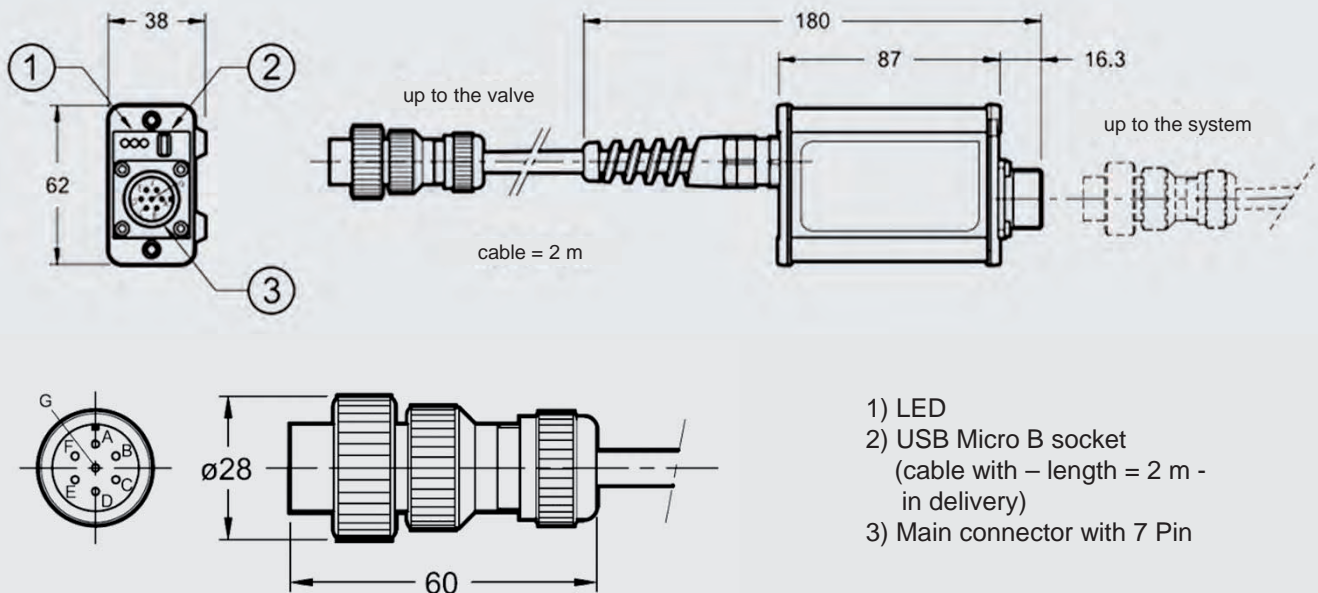

In the casing of electronics, a 7-pole port for connecting with external devices is integrated.

The cable diameter for the main connector (cable and connector are not included in delivery) has to be min. 8 mm and should be max. 10 mm.

Hint

We recommend the use of a metal connector to ensure electromagnetic compatibility (EMC) and to avoid electromagnetic disturbances.

Note

The information in this brochure relates to the operating conditions and applications described. For applications not described, please contact the relevant technical department.
All technical details are subject to change without notice.

HYDAC Fluidtechnik GmbH
Justus-von-Liebig-Str.
D-66280 Sulzbach/Saar
Tel: 0 68 97 /509-01
Fax: 0 68 97 /509-598
E-Mail: valves@hydac.com

4/3 proportional directional valves hydraulic pilot operated with Onboard Electronic and transducer P4WEHRE 10 to 25

DESCRIPTION

The P4WEHRE is a pilot operated proportional directional valve with integrated electronic and transducer, which combines directional control with speed control of the consumer.

The controlled volume flow is proportional to the electrical input signal on valve electronics.

According to the input signal, the magnet generates a control pressure, which shifts hydraulically the main piston against a spring. In this process, cross-sections are released, which determine the size of the volume flow depending on the pressure difference.

The integrated digital electronics in combination with the transducer allows improved performance and function due to

- regulation of size and direction of a volume flow
- short response times
- low hysteresis
- high repeatability

FEATURES

- High flow capacity due to optimized, cast casing
- Low hysteresis due to precision machining of moving parts
- The pilot supply or pilot drain can be internal or external
- The control results directly from the integrated Onboard electronic
- Easy interchangeability due to internationally standardised interface according to ISO 4401

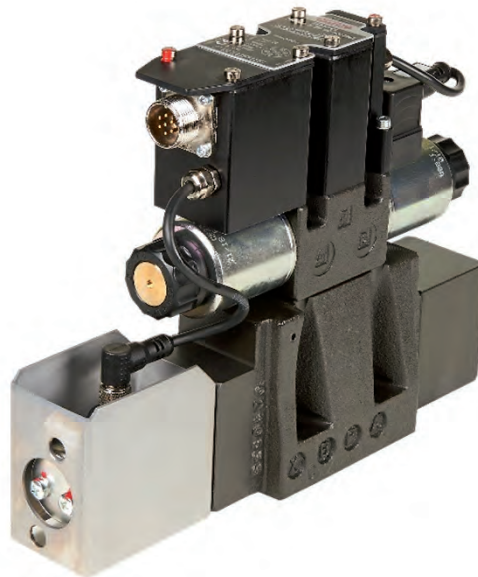

CONTENT

Description
Features
Model code
Spool types / Symbols
Technical Data
Function
Section view
Accessories
Performance
Dimensions
Electronic

MODEL CODE

P4WEHRE E 10 E80 D01-24PG E0B/V/D

Type

Proportional 4 directional valve, electrical / hydraulic with Onboard Electronic (OBE) and transducer

Control type

E = external pilot supply and drain
EI = external pilot supply, internal pilot drain
IE = internal pilot supply, external pilot drain
I = internal pilot supply and drain

Nominal size (NG)

10, 16, 25

Symbols

see chapter „Spool types / Symbols“

Nominal flow (at $\Delta p = 10$ bar, P – T)

80 = 80 l/min
80/40 = 80 l/min (P → A or A → T) / 40 l/min (B → T or P → B)
further nominal flows see „Nominal flow ranges“
in chart „Hydraulic specifications“

Series

D01 = standard
D02 = ISO 4401-05-05-0-05 (NG10 only)

Rated voltage of the solenoid coil

24 = 24 V DC

Coil Type

PG = 7-pin MIL-C-5015-G (DIN-EN 175201-804)

Input signal

E0 = ± 10 V
E1 = 4 – 20 mA

Pin C Function

see „Diagrams Pin C Function“ in chapter „Electronic“

Sealing material

V = FKM (standard)
N = NBR

Pressure reducing valve (30 bar fixed)

Necessary if control pressure at port X is higher than 210 bar

SPOOL TYPES / SYMBOLS

Type	Basic symbol	Type	Basic symbol
E		J	
EA		JA	

TECHNICAL DATA ¹

General specifications

	Nominal size		
	10	16	25
MTTF _d :	According to EN ISO 13849-1:2015 chart C1 & C2		
Ambient temperature:	[°C] -20 to +60		
Installation position:	No orientation restrictions		
Weight:	[kg] 9,0	11,0	17,5
Material:	Valve casing:	Cast iron	
	Name plate:	Aluminium	
Surface coating:	Valve casing:	Phosphate	

Hydraulic specifications

	Nominal size			
	10	16	25	
Operating pressure:	[bar]	Port P: p _{max} = 350 Port T, internal leak port: p _{max} = 10 Port T, external leak port: p _{max} = 250		
Control pressure:	[bar]	p _{min} = 30 p _{max} = 210		
Max. nominal flow:	[l/min]	180	450	800
Nominal flow ranges:	[l/min]	80	100	200
(at Δp = 10 bar, P → T)		80/40	150	300
			150/75	300/150
Operating fluid:	Hydraulic oil to DIN 51524 part 1, 2 and 3			
Media operating temperature range:	[°C]	-20 to +80		
Viscosity range:	[mm ² /s]	10 – 400		
Permitted contamination level of operating fluid:	class 18/16/13 to ISO 4406			
Sealing material:	NBR, FKM (standard)			
Control flow:	[l/min]	3,5	6,4	15,3
(Control 0 → 100 %)				
Control volume:	[cm ³]	1,7	3,2	9,2
(Control 0 → 100 %)				

Electrical specifications

	Nominal size		
	10	16	25
Switching time (0 → 100%):	[ms] 50	80	100
Switching time (100% → 0):	[ms] 40	50	70
Type of voltage:	DC		
Rated voltage:	[V] 12, 24		
Hysteresis:	[%] < 0,5 of Q _{max}		
Repeatability:	[%] < ±0,2 of Q _{max}		
Protection class to DIN EN 60529:	with electrical connection "G" IP65 ²		

Hint

If the system pressure exceeds the max. allowable control pressure, it is necessary to use the version with external control and control pressure within the specifications. Otherwise, the valve with internal pilot control and pressure reducing valve as 30 bar fixed sandwich plate can be ordered.

¹ see „Conditions and Instructions for Valves“ in brochure 53.000

² if installed correctly

FUNCTION

The P4WEHRE is a hydraulic pilot operated, proportional 4 directional valve with integrated OBE and transducer.

The volume flow is controlled continuously (proportionally) to the electrical input signal at the solenoid coil.

These valves essentially consist of the pilot stage (pressure regulating valve) and the main stage (directional valve).

The pilot stage consists of the valve housing (1), a control piston with 2 pressure measuring pins (2) and two proportional solenoids (3). The proportional solenoid coils are controlled via the integrated Onboard electronic (7). OBE and pilot stage are connected via the main connector (8). The main stage consists of the housing (4), a main piston (5) and a centring spring (6) acting in both directions.

The transducer (9) in the main stage monitors the position of the main piston.

The pressure supply of the valve results from the interface according to ISO 4401. The external pilot supply and drain result from port X and Y to the pilot valve. The regulated control pressure is proportional to the stroke of the main stage. If one of the two solenoids is energized, the pilot releases the connection to control port A or B and regulates the control pressure according to the set solenoid current.

The main piston shifts until a balance of force is reached by pressurizing one of the two sides of the main piston via control pressure. The desired connection PABT or PBAT is released. The transducer makes a target-performance comparison of the main piston position and corrects differences via OBE.

If the valve is subsequently relieved of pressure, the centring spring returns the main piston to neutral again.

P4WEHRE valves are available in different versions, which differ in their interface. Due to this difference, the valve versions are not compatible with each other.

SECTION VIEW

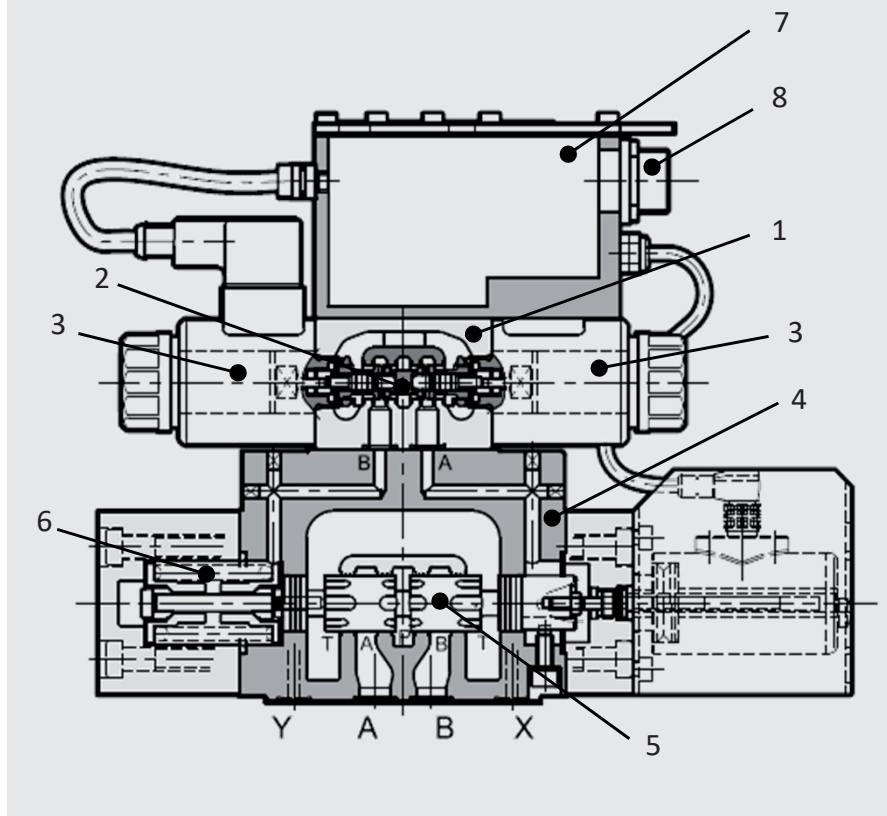

ACCESSORIES

	Designation	Part no.
Seal kits (main stage)	P4WEHRE 10: 12,42 x 1,78 90 Sh (5 pcs)	FKM: 3524523
	9,25 x 1,78 90 Sh (2 pcs)	NBR: 3524475
	P4WEHRE 16: 22,22 x 2,62 90 Sh (4 pcs)	FKM: 3524634
	10,82 x 1,78 90 Sh (2 pcs)	NBR: 3524553
Mounting screws	P4WEHRE 25: 29,82 x 2,62 90 Sh (4 pcs)	FKM: 3524660
	20,24 x 2,62 90 Sh (2 pcs)	NBR: 3524659
	P4WEHRE 10: ISO 4762 M6 x 35 (4 pcs)	604593
Main Connector	P4WEHRE 16: ISO 4762 M10 x 60 (4 pcs)	4501973
	ISO 4762 M6 x 60 (2 pcs)	4501973
	P4WEHRE 25: ISO 4762 M12 x 60 (6 pcs)	619501
Electronic	6+PE EN175201 Part 804	6080324
	Lin-Bus Interface	3648934

PERFORMANCE

The performance represent typical curves for the various available valve pistons, at a constant Δp , depending on the current supplied by the solenoid coil.

(Note: The maximum current for the solenoid version D24 is 800 mA).

The total valve pressure drop (Δp) was measured between port P and T of the valve.

Q-I-Performance NG10

(measured at 36 cSt, 50°C), symbols E; EA; EB; Q; QA; QB, nominal flow 80 l/min

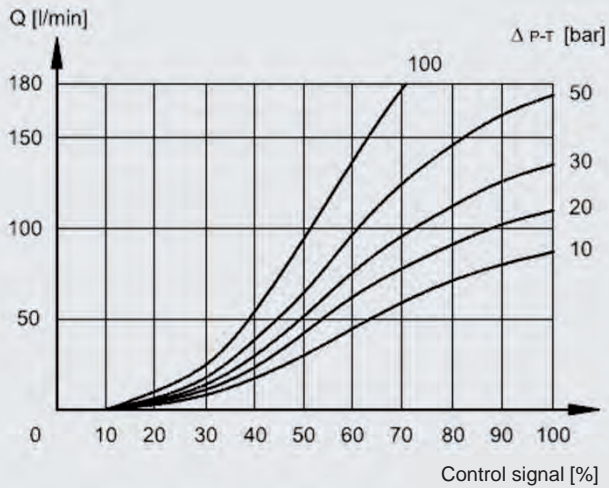

Q-I-Performance NG16

(measured at 36 cSt, 50°C), symbols E; EA; EB; Q; QA; QB, nominal flow 100 l/min

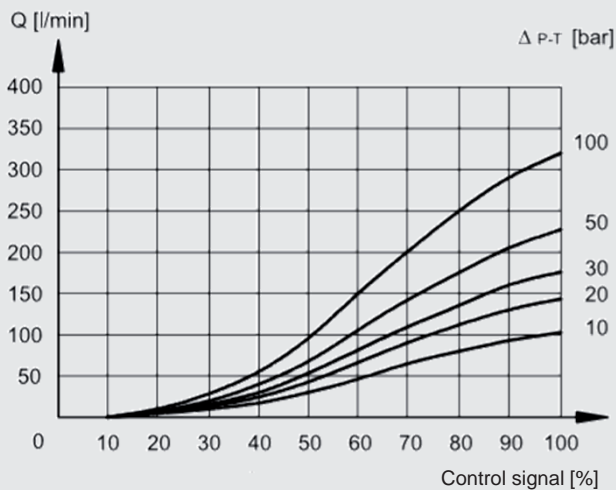

Nominal flow 150 l/min

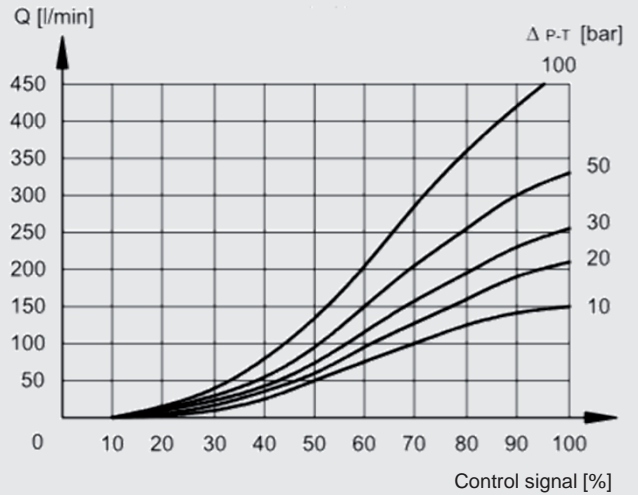

Q-I-Performance NG25

(measured at 36 cSt, 50°C), symbols E; EA; EB; Q; QA; QB, nominal flow 200 l/min

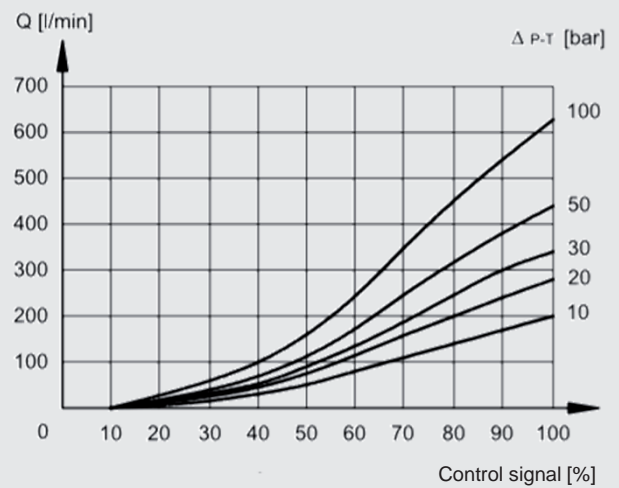

Nominal flow 300 l/min

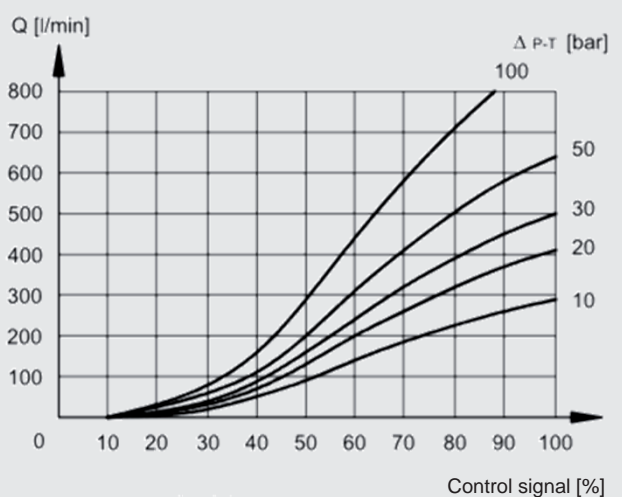

PERFORMANCE

Switching time (measured at 36 cSt, 50°C), symbols E, EA, EB, Q, QA

NG10

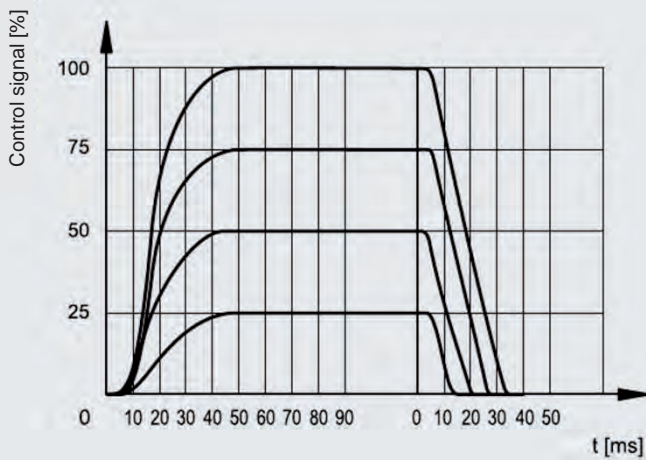

NG16

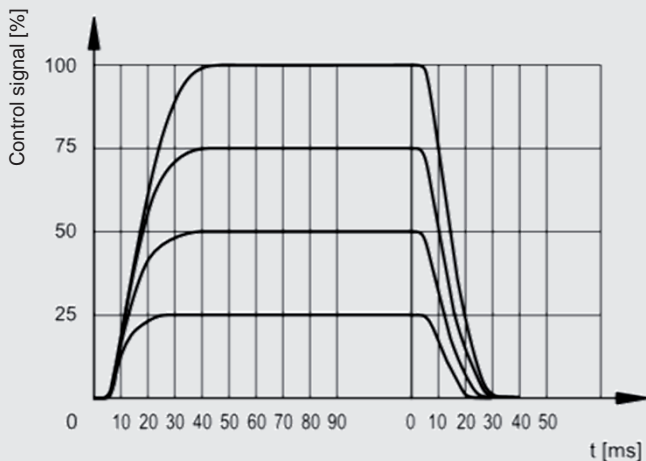

NG25

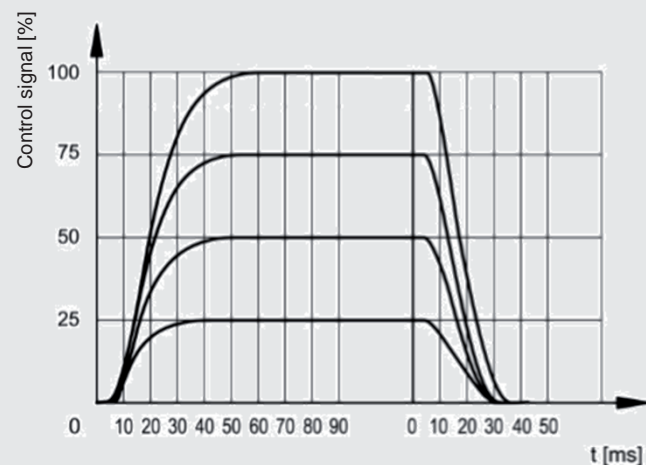

Plug

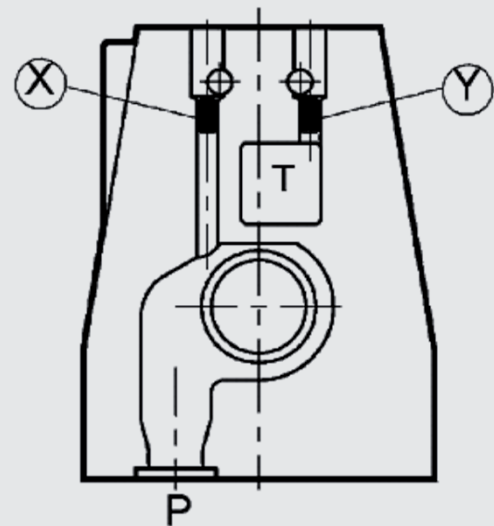

Control type		Installation	
		X	Y
E	external pilot supply and drain	●	●
EI	external pilot supply, internal pilot drain	●	-
IE	internal pilot supply, external pilot drain	-	●
I	internal pilot supply and drain	-	-

- **Version „E“**
Pilot oil supply is external from a separate fluid power supply via port X.
The pilot oil drain is also external via port Y.
- **Version „EI“**
Pilot oil supply is external from a separate fluid power supply via port X.
The pilot oil drain is internal via port T.
- **Version „IE“**
Pilot oil supply is internal via port P.
The pilot oil drain is external via port Y.
- **Version „I“**
Pilot oil supply is internal via port P.
The pilot oil drain is internal via port T.

The valve is configured and delivered as required.
The threaded plugs are glued in at delivery.
Subsequent modification is not possible.

DIMENSIONS NG10

INTERFACE

CETOP 4.2-4 P05-350 (D01)

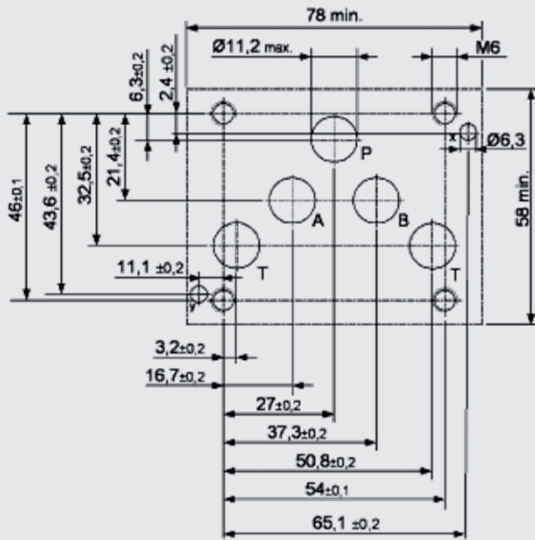

INTERFACE

ISO 4401-05-05-0-05 (D02)
(CETOP 4.2-4 R05-350)

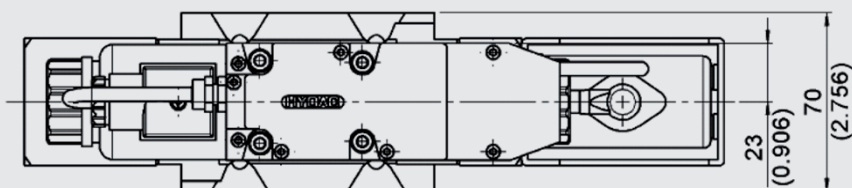
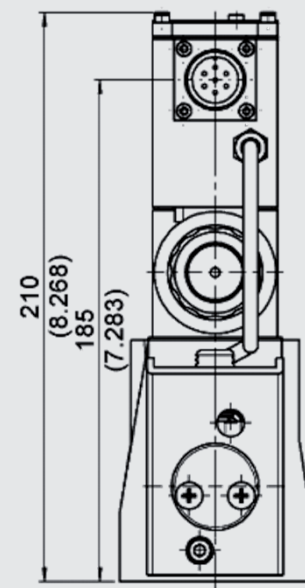
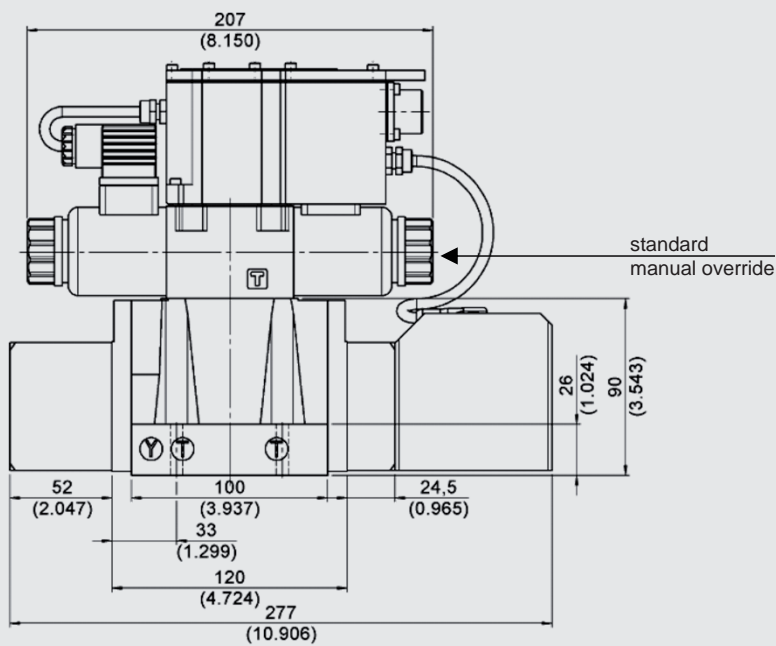
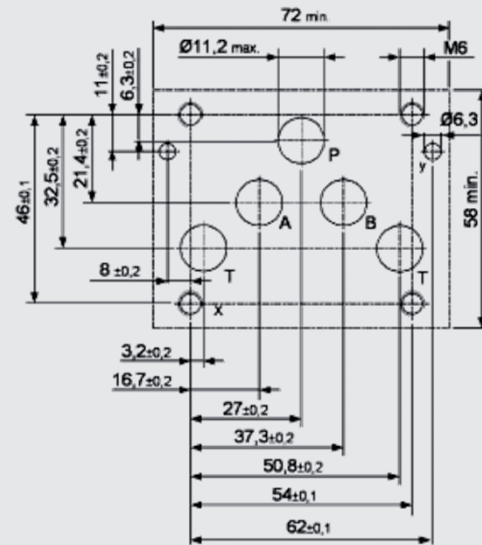

Hint

When using the pressure reducing as sandwich plate, the installation height changes by 40 mm to 250 mm.

Mounting screws (ISO 4762): 4 pcs M6 x 35 A8.8 (not included in delivery)
Torque: 8 Nm

DIMENSIONS NG16

INTERFACE

ISO 4401-07-07-0-05 (D01)
(CETOP 4.2-4-07-350)

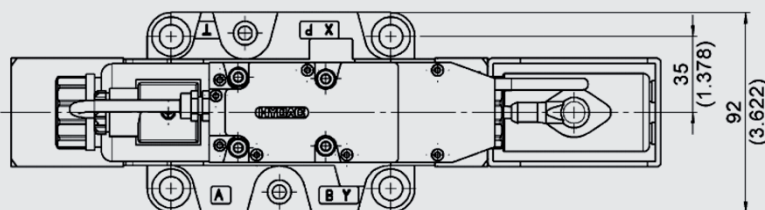
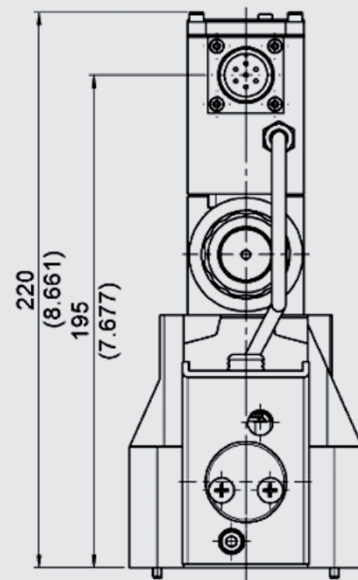
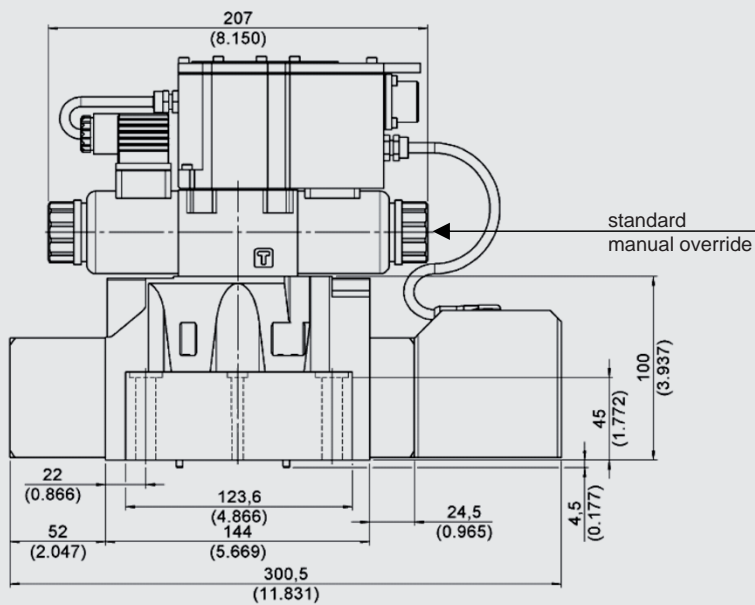
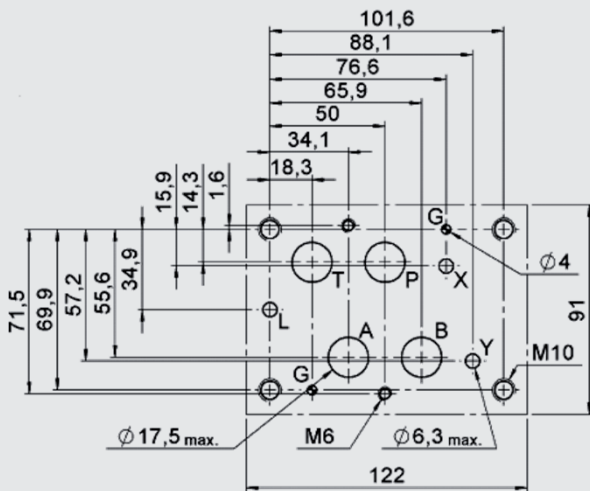

Hint

When using the pressure reducing as sandwich plate, the installation height changes by 40 mm to 260 mm.

Mounting screws (ISO4762): 4 pcs M10x60 A8.8 (not included in delivery)
2 pcs M6 x 60 A8.8 (not included in delivery)

Torque: M10: 40 Nm
M6: 8 Nm

INTEGRATED ELECTRONIC

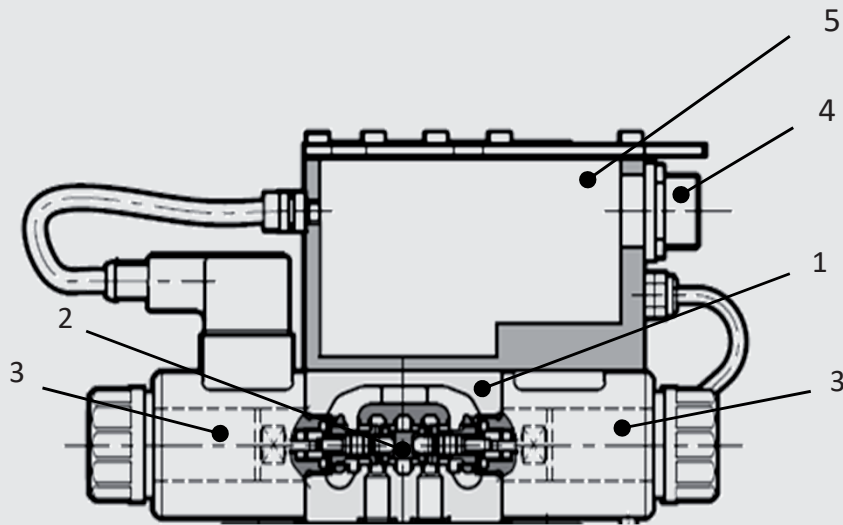

Parameterisable only via LIN bus

- 1) Valve with proportional solenoids
- 2) Valve piston
- 3) Proportional solenoid
- 4) Main connector
- 5) Electronic housing

General specifications

Power consumption:	25 W
Current consumption:	max. 1,88 A
Rated voltage:	24 V DC (19 – 30 V DC, ripple max. 3 Vpp)
Duty cycle:	100% ED (continuous)
Control signal E0:	Voltage signal ± 10 VDC
Control signal E1:	Current signal 4 – 20 mA
Alert signale:	Overload and overheating of electronics
Communication:	LIN-Bus ISO 11898 LIN-Bus Interface
Electronical connection:	7-pin MIL-C-5015-G (DIN-EN 175201-804)
LIN-Bus connection:	M12-IEC 60947-5-2
EMC EN61000-6-4:	According to 2014/30/EU standard
EMC EN61000-6-2:	According to 2014/30/EU standard
Type of protection:	IP65 / IP67 (CEI EN 60529 standard)

ELECTRONIC

Standard version with reference signal voltage E0

PIN	Value	Version A	Version B	Version C
A	24 V DC	Supply voltage		
B	0 V			
C		release 24 V DC	unoccupied	PIN F reference 0 V
D	+/- 10 V	control (differential input)		
E	0 V	PIN D reference		
F	+/- 10 V	monitor (0V reference PIN B)		monitor
PE	GND	earth (mass)		

Standard version with reference signal current E1

PIN	Value	Version A	Version B	Version C
A	24 V DC	Supply voltage		
B	0 V			
C		release 24 V DC	unoccupied	PIN F reference 0 V
D	4 - 20 mA	control		
E	0 V	PIN D reference		
F	4 - 20 mA	monitor (feedback) (0V reference PIN B)		monitor (feedback)
PE	GND	earth (mass)		

Diagrams PIN C Function

Version A: External release (on request)

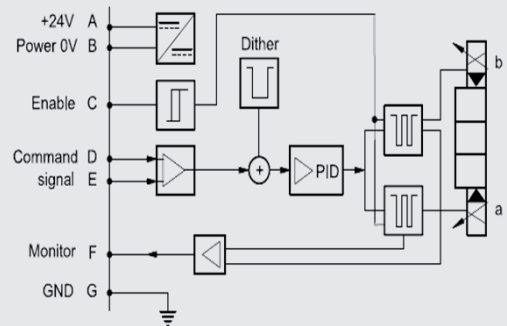

Version B: Internal release (standard)

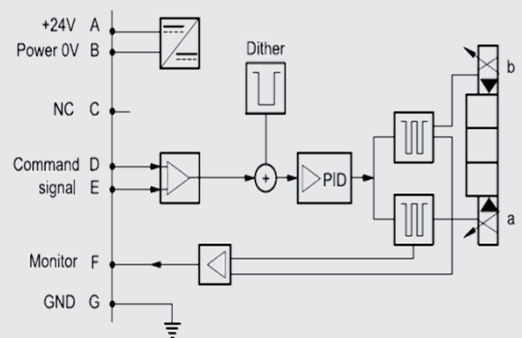

Version C: 0V Monitor (on request)

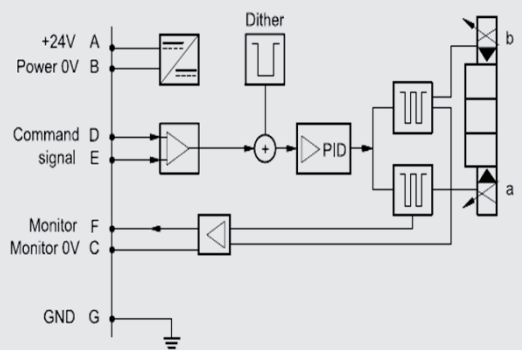

Hint 1

- Voltage signal (0V centring position)
 - -10V to 0 V: flow direction P – B and A – T
 - 0V to +10V: flow direction P – A und B – T
- Current signal (12 mA centring position)
 - 4 mA to 12 mA: flow direction P – B and A – T
 - 12 mA to 20 mA: flow direction P – A and B – T
- With one solenoid (type EA and JA)
 - 4 mA to 20 mA: flow direction P – B and A – T
 - 0V to +10V: flow direction P – B and A – T

Pin D and Pin E must always be contacted.

Hint 2

PIN C function A and B: Nominal input value measured between pin F and pin B.

Hint 3

We recommend to provide an external protection at pin A (24 V DC) for protection of the electronics: 5A/50V fast fuse.

LIN-BUS INTERFACE

Is also required for parameterisation of Onboard electronic.

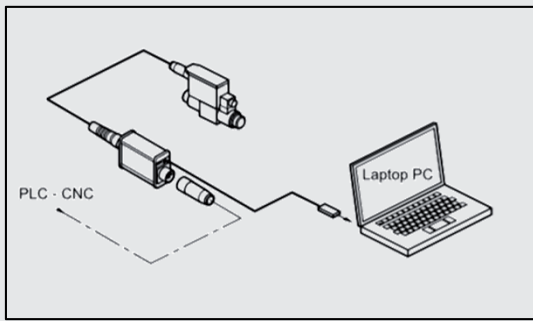

- The kit contains a test device with embedded connection cable 7 pin and a USB cable for connection to the PC. The dedicated software are available for download from our website.
- The device is suitable for troubleshooting and functional testing of HYDAC proportional valves with LIN-bus interface.
- The software allow the check of settings, display the diagnostic and permit to make changes on the standard parameter setting made in factory, adapting it to your system.
- No additional power supply is required: the device uses the supply source from the 7 PIN system cable.

Content*: Parameterize-software, adapter and PC connection cable

* On request (not included in delivery)

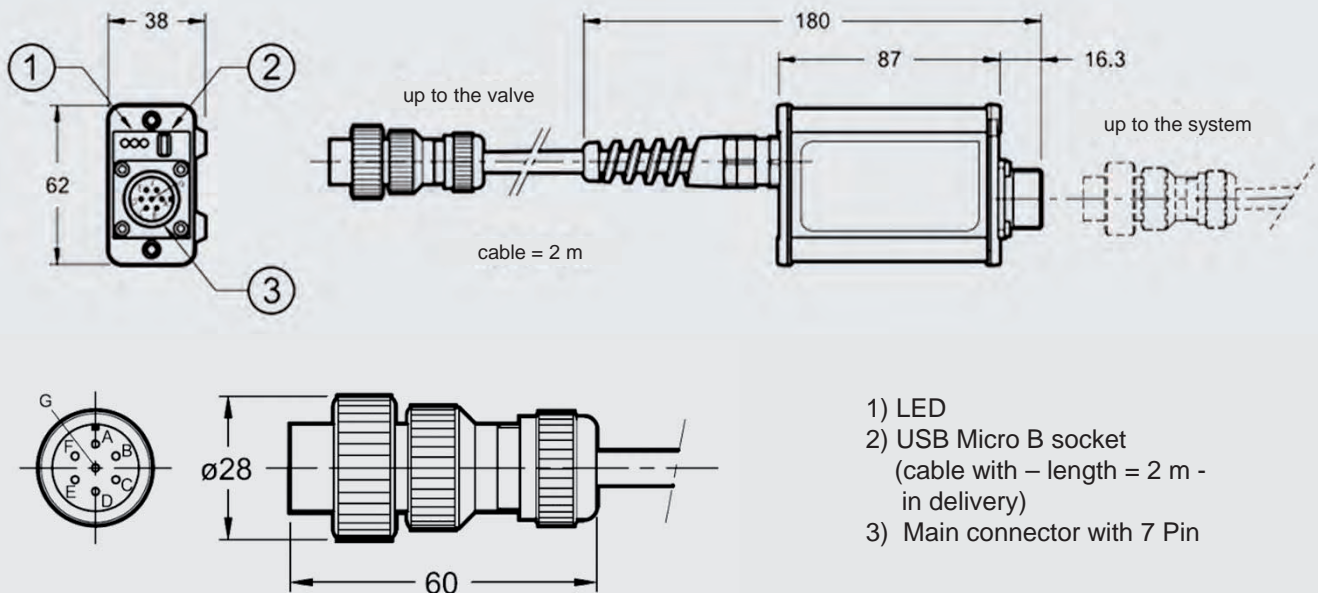

In the casing of electronics, a 7-pole port for connecting with external devices is integrated.

The cable diameter for the main connector (cable and connector are not included in delivery) has to be min. 8 mm and should be max. 10 mm.

Hint

We recommend the use of a metal connector to ensure electromagnetic compatibility (EMC) and to avoid electromagnetic disturbances.

Note

The information in this brochure relates to the operating conditions and applications described. For applications not described, please contact the relevant technical department.

All technical details are subject to change without notice.

HYDAC Fluidtechnik GmbH

Justus-von-Liebig-Str.

D-66280 Sulzbach/Saar

Tel: 0 68 97 /509-01

Fax: 0 68 97 /509-598

E-Mail: valves@hydac.com

4/3 proportional directional spool valve Control valve with On-Board Electronic and transducer solenoid-operated, direct-acting C4WERE 6

DESCRIPTION

HYDAC 4/3 control valves of the C4WERE 6 series are direct-acting, electrically operated spool valves.

The valve operates by oil-immersed control solenoid. During this process, the solenoid quickly and precisely pushes the valve's control piston into the respective position to obtain the desired flow path. The position of the piston is proportional to the input signal and is controlled by integrated electronics and direction control (LVDT).

FEATURES

- Application for position, pressure and speed control
- Resistant to contamination due to powerful solenoids
- Easy to use due to plug-and-play design
- High dynamic and very good response
- Interface according to ISO 4401-03; DIN 24340 Form A6

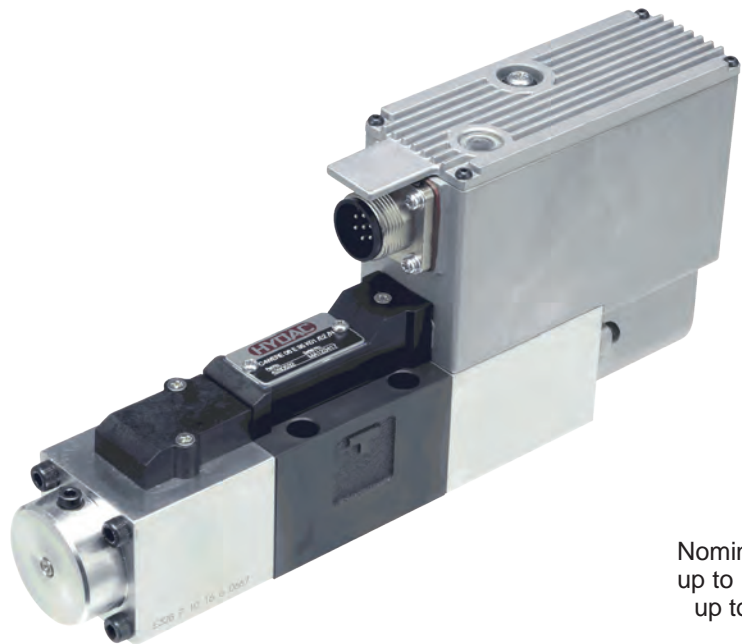

Nominal size 6
up to 100 l/min
up to 350 bar

CONTENTS

Description
Features
Model code
Spool types / symbols
Fail-safe function (option)
Function
Section view
Technical data
Performance
Dimensions
Electronics
Block diagram
Accessories

MODEL CODE

C4WERE 6 Z - FA 35 K01 / E0B / V

Type

Solenoid-operated control valve with integrated electronic and positional transducer, direct acting

Nominal size

6

Spool symbol

See page 275

Fail-safe function

Not specified = no fail-safe function (standard)

FA = ports P and B to ports A and T

FB = ports P and A to ports B and T

Flow rate (at 10 bar Δp port P to T)

10 = 10 l/min

20 = 20 l/min

35 = 35 l/min

Series

K01 = standard

Input signal

E0B = voltage ± 10 V

E1B = current 4 – 20 mA

Sealing material

N = NBR

V = FKM (standard)

SPOOL TYPES / SYMBOLS

2/2-DIRECTIONAL SPOOL VALVES

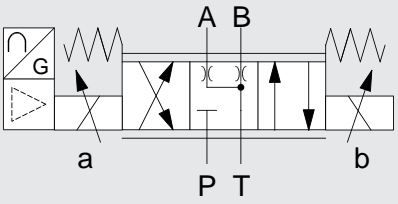
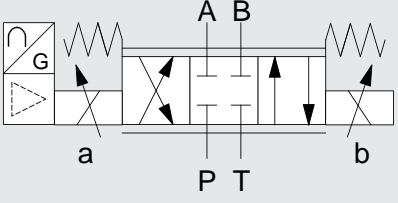
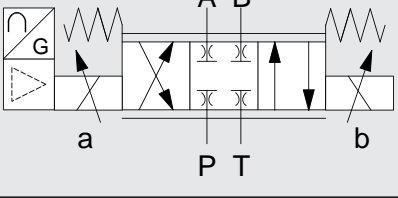
Type	Symbol	Description
Q		
E		10% overlap with total stroke*
Z		2% overlap with total stroke*

*Full piston stroke = 2.5 mm

FAIL-SAFE FUNCTION (OPTION)

Position of the piston in the absence of power supply:

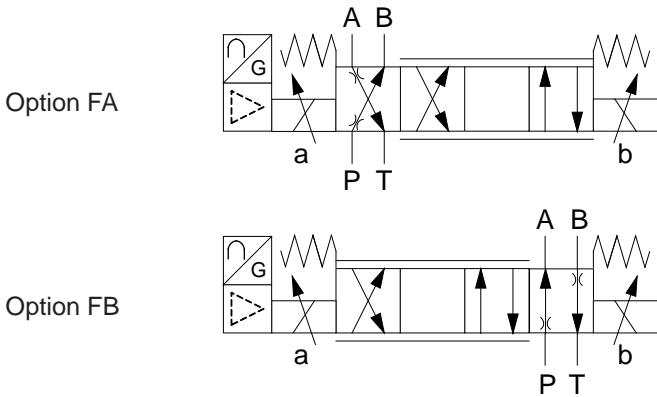

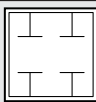
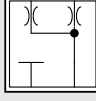
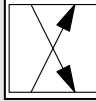
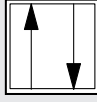
Designation	Spool position	Symbol
C4WERE 6 E .. K01/.../.	Centre position: All ports blocked	 Spool E
C4WERE 6 Q .. K01/.../.	Centre position: From port A and B low leakage to T	 Spool Q
C4WERE 6 -FA .. K01/.../.	20% of total stroke Equivalent to approx. 20% from Q_{NOM}	 Spool E, Z and Q
C4WERE 6 -FB .. K01/.../.	20% of total stroke Equivalent to approx. 20% from Q_{NOM}	 Spool E, Z and Q

FUNCTION

The solenoid-operated proportional directional spool valves of the C4WERE 6 series are used to control a flow precisely and dynamically.

The valve consists of a valve casing (1) with corresponding valve piston (2). It has two return springs (3) and is equipped with two powerful control solenoids (4), as well as a transducer (5) and On-Board Electronic (6).

The On-Board Electronic convert an analogue nominal value signal into a proportional spool design in relation to the return spring. Thus releases or closes flow directions between the respective ports. The force needed to perform the spool design is generated by the solenoid. The transducer constantly records the current position - the On-Board Electronic sets the necessary control current for stabilization of nominal position of the valve piston by comparing the nominal and current position. This results a constantly increasing flow even if the pressure difference through the valve is increasing.

In the absence of power supply on the valve, the return springs shift the valve piston back in a safe position (fail-safe function).

SECTION VIEW

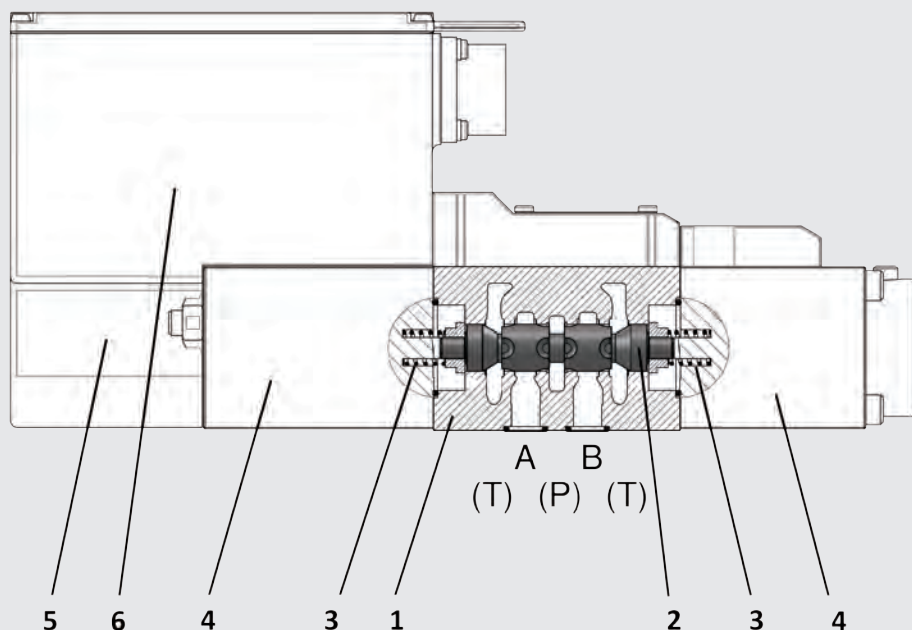

TECHNICAL DATA ¹⁾

General specifications	
Ambient temperature:	[°C] 0 to 50
Installation position:	Horizontal +/- 15°
Weight:	[kg] 3.3
Material:	Valve casing: Cast iron
	Electronic casing: Metal die-cast
	Coil casing: Steel
	Name plate: Aluminium
Surface coating:	Valve casing: Phosphate plated
Hydraulic specifications	
Operating pressure:	[bar] 350
Tank pressure:	[bar] 210
Flow rate: Q_{NOM} (at 10 bar Δp p→T)	[l/min] 10 = 10 l/min 20 = 20 l/min 35 = 35 l/min
Operating fluid:	Hydraulic oil to DIN 51524 Part 1, 2 and 3
Temperature range of operating fluid:	[°C] -15 to +60
Viscosity range:	[mm ² /s] 15 to 400
Permitted contamination level of operating fluid:	Class 18/16/13 according to ISO 4406
Sealing material:	FKM (standard), NBR
Electrical specifications	
Hysteresis:	[%] 0.1
Repeatability:	[%] 0.1
Protection class according to DIN EN 60529:	IP65

¹⁾ see "Conditions and Instructions for Valves" in brochure 53.000

PERFORMANCE

Example Z spool

Frequency range

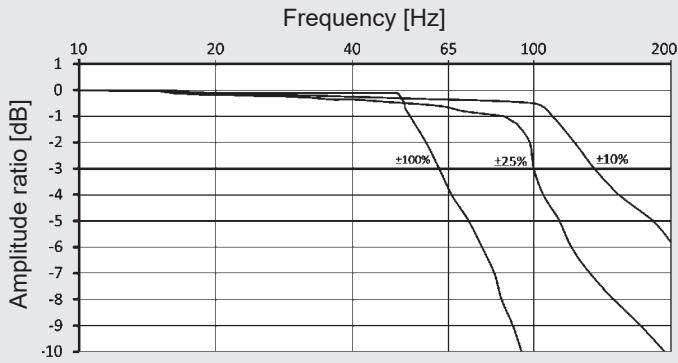

Switching times

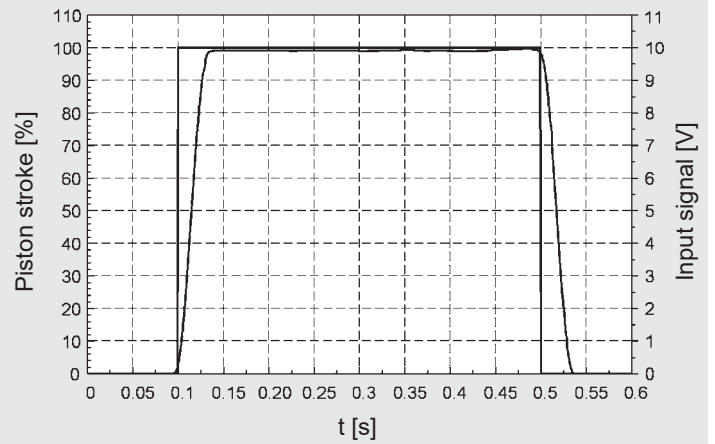

Pressure increase

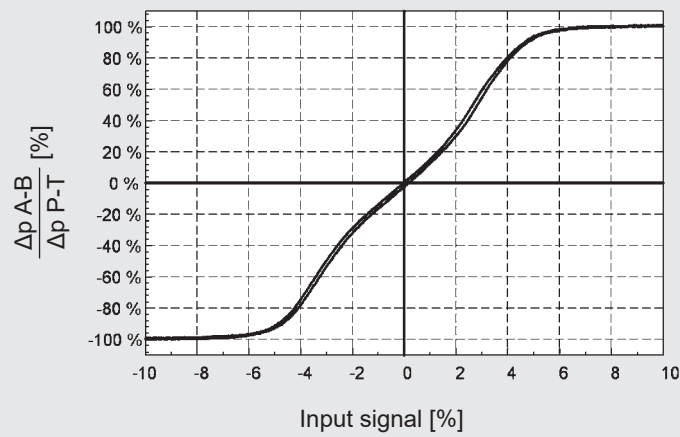

Flow rate vs pressure loss

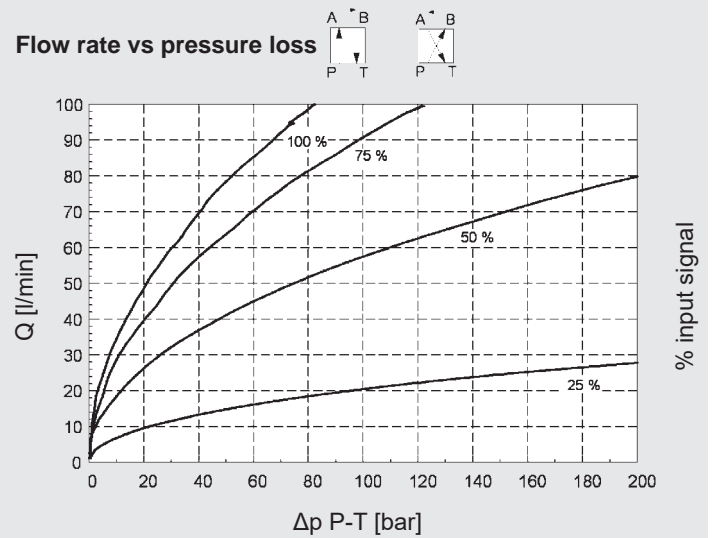

Flow increase (Δp P-T: 10 bar)

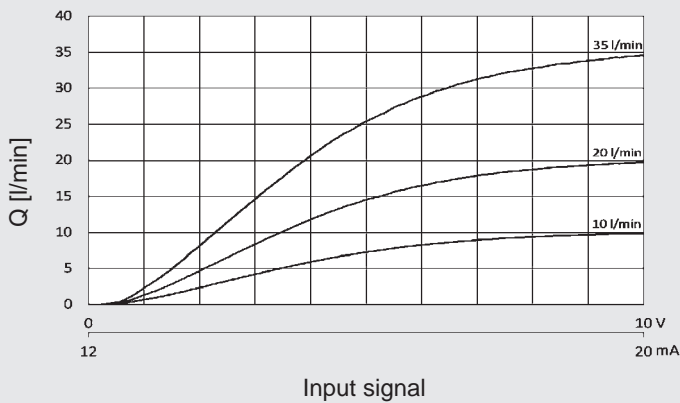

Calculation of the flow rate (at pressure difference > 10 bar)

$$Q_x = Q_{NOM} \times \sqrt{\frac{\Delta p_x}{10}}$$

DIMENSIONS

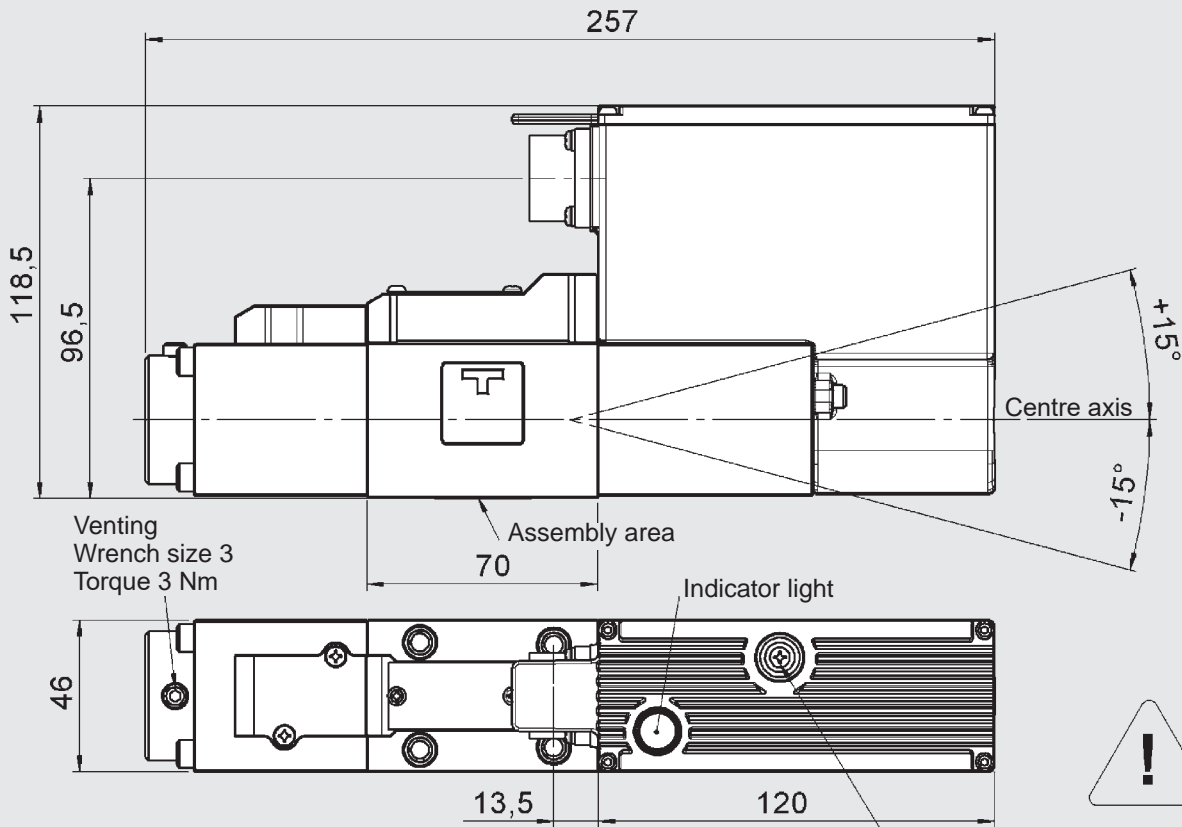

Protective screw
NULL adjustment hole:
Null position is adjusted at
factory.
For Null adjustment remove
the screw and turn the
trimmer behind it.
After adjustment attach the
screw again.

Interface to ISO 4401-03-02-0-05 (CETOP 4.2-4-03-350)

Mounting screws (included in delivery):

4 screws ISO 4762 M5x45

Tightening torque: 7 Nm (screws A 10.9)

Clamping length: 38 mm

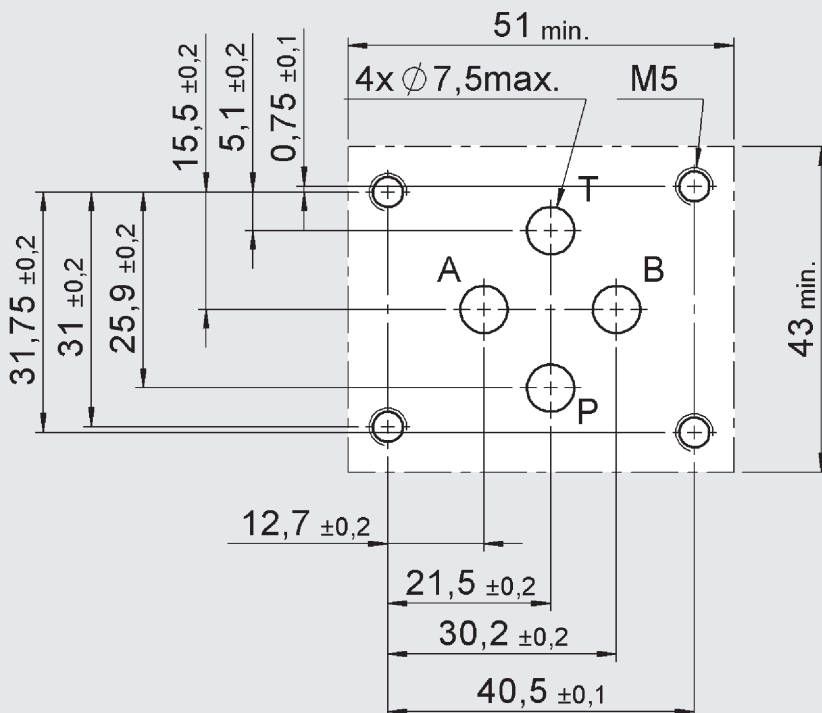

Pin assignment

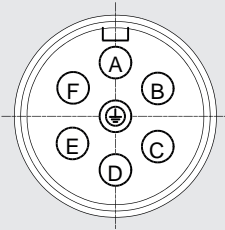

Metal connector

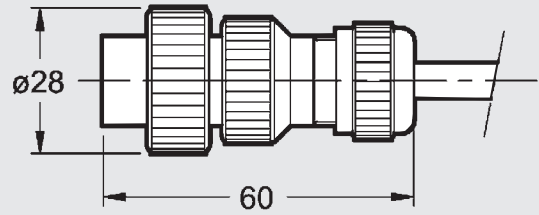

The outside diameter of the cable sheath for the connector (cable and connector are not included in delivery) must be min. 8 mm and can be max. 10 mm.

OPERATING MODALITIES

Code		C4WERE.../E1B	C4WERE.../E0B
PIN A	Power supply	24 V DC (21.6 - 26.4 V DC) *3	
PIN B		0 V	
PIN C	Signal common	COM (0 V)	
PIN D	Input (+) (differential) *1	4-20 mA	± 10 V
PIN E	Input (-) (differential) *1	Ri = 200 Ω	Ri ≥ 50 kΩ
PIN F	Spool travel monitoring	4-20 mA	± 10 V
		Ri = 100 - 500 Ω*2	Ri ≥ 10 kΩ
PIN	Protective earth	-	

*1 The different input signal is only used for the type C4WERE.../E0

*2 Recommended load resistance Ri = 200 Ω

*3 Power consumption max. 75 VA and without nominal value setting min. 16 VA

BLOCK DIAGRAM

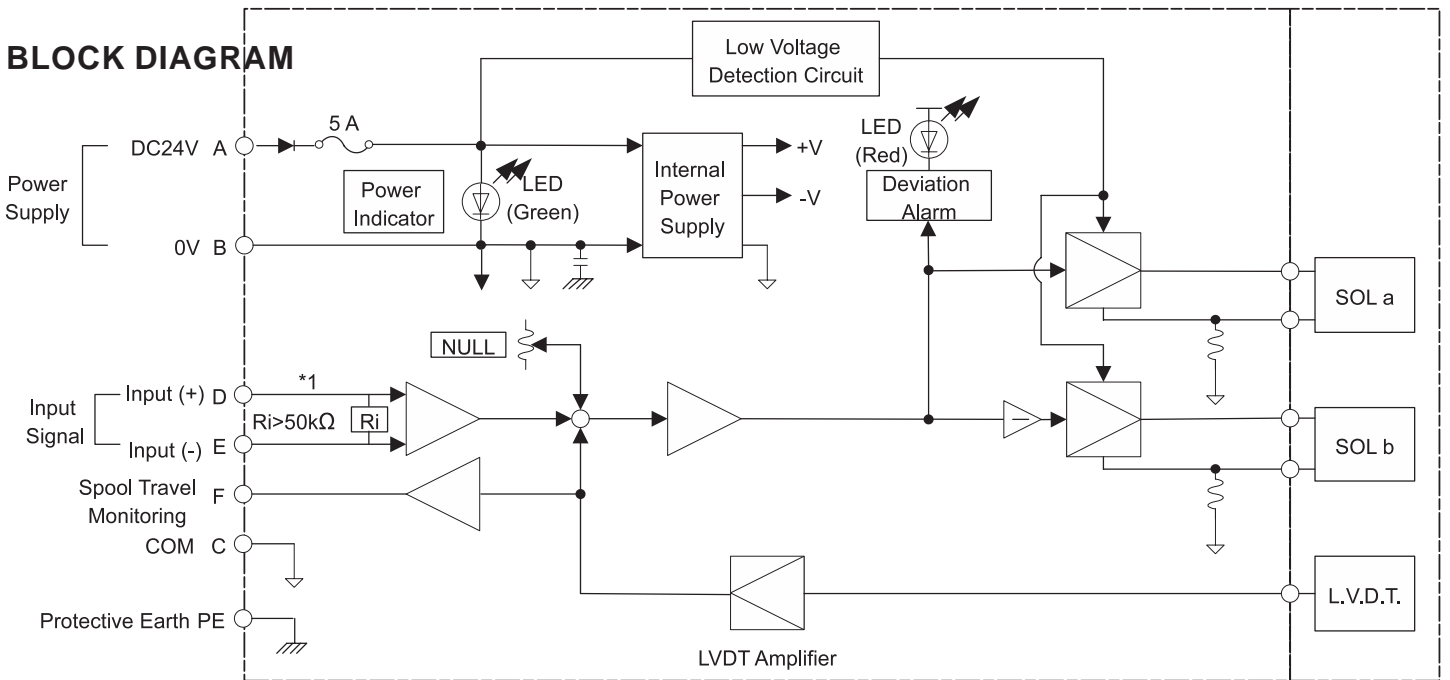

*1 The input stage for input signal 4–20 mA is as follows:

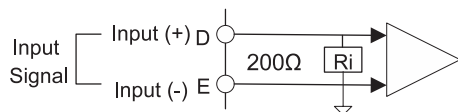

ACCESSORIES

Designation	Part no.
Connector for valves with On-Board Electronic	6080324

NOTE

The information in this brochure relates to the operating conditions and applications described. For applications or operating conditions not described, please contact the relevant technical department.

Technical modifications are reserved.

Pressure relief valve pilot operated VP-DBP10

DESCRIPTION

HYDAC pilot-operated pressure relief valves limit pressure in meter-in in the system or control the power build-up in meter-out in hydraulic actuators.

FEATURES

- Interface according to ISO 6264-08
- Low flow loss due to maximum size bore holes
- Remote control via port X possible



Nominal size 10
up to 400 l/min
up to 350 bar

CONTENT

Description

Features

Model code

Spool types / Symbols

Accessories

Function

Section view

Technical Data

Performance

Dimensions

MODEL CODE

VP-DBP 10 070 V S01 / V

Type

Pressure relief valve, pilot operated

Nominal size

10

Pressure ranges

070 = 4 up to 70 bar
 210 = 4 up to 210 bar
 350 = 4 up to 350 bar

Type of adjustment

V = adjustable with tool

Series

S01 = standard

Sealing material

V = FKM
 N = NBR

SPOOL TYPES / SYMBOLS

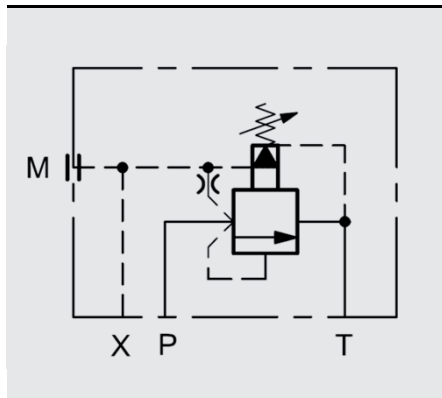

ACCESSORIES

	Designation	Part no.
Seal kits (3-part set)	29,82 x 2,62 -FKM -90 Sh (2 pcs)	3526098
	9,13 x 2,62 -FKM -90 Sh (1 pcs)	
	29,82 x 2,62 -NBR -90 Sh (2 pcs)	3526094
	9,13 x 2,62 -NBR -90 Sh (1 pcs)	
Mounting screws (4 pcs)	DIN EN ISO 4762-M16x50-10.9	603171

FUNCTION

The pilot operated pressure relief valve VP-DBP10 has a pilot and a main stage – both are poppet type. Its function is to limit the pressure in the system.

The valve is normally closed. If the hydraulic force at port P exceeds the pre-set spring tension of the pilot stage, the poppet opens and oil flows from the rear of the main piston to the tank port T. Due to the resulting pressure difference, the main piston moves against the return spring and allows oil from port P to T. This continues until the system pressure is equal to the spring pressure and the valve closes again.

Attention:

Pressures at port T increase the cracking pressure.

SECTION VIEW

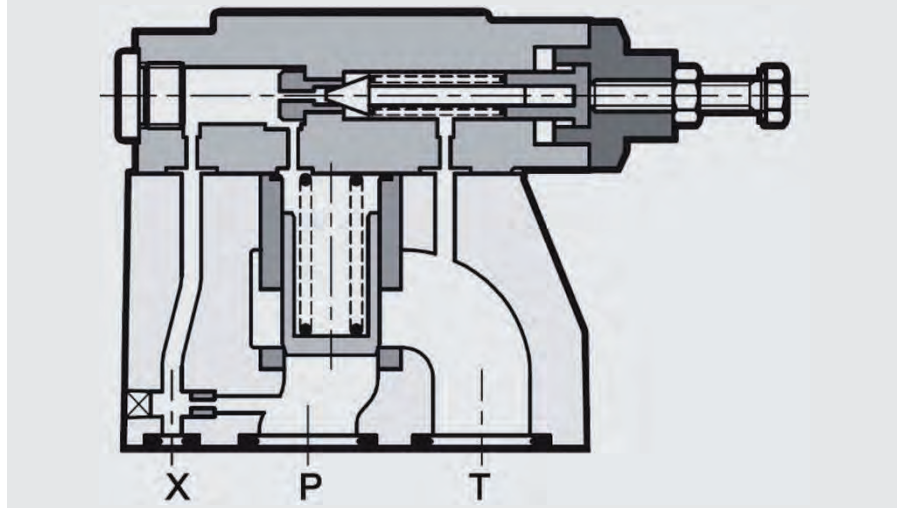

TECHNICAL DATA ¹

General specifications

MTTF _d :	According to EN ISO 13849-1:2015 chart C1 & C2		
Ambient temperature:	[°C]	-20 to +50	
Installation position:	No orientation restrictions		
Weight:	[kg]	4,3	
Material:	Valve casing:	Cast iron	
	Name plate:	Aluminium	
Surface coating:	Valve casing:	Phosphate plated	

Hydraulic specifications

Operating pressure:	[bar]	Port X, P, T:	$p_{max} = 350$
Pressure ranges:	[bar]	4 up to 70 4 up to 210 4 up to 350	
Nominal flow:	[l/min]	400	
Operating fluid:	Hydraulic oil to DIN 51524 part 1, 2 and 3		
Media operating temperature range:	[°C]	-20 to +80	
Viscosity range:	[mm ² /s]	10 – 400 (25 is recommended)	
Permitted contamination level of operating fluid:	Class 20/18/15 to ISO 4406		
Sealing material:	FKM, NBR		

¹ see „Conditions and Instructions for Valves“ in brochure 53.000

PERFORMANCE

Pressure drop

measured at $v = 36 \text{ mm}^2/\text{s}$ and $T_{oil} = 50^\circ\text{C}$

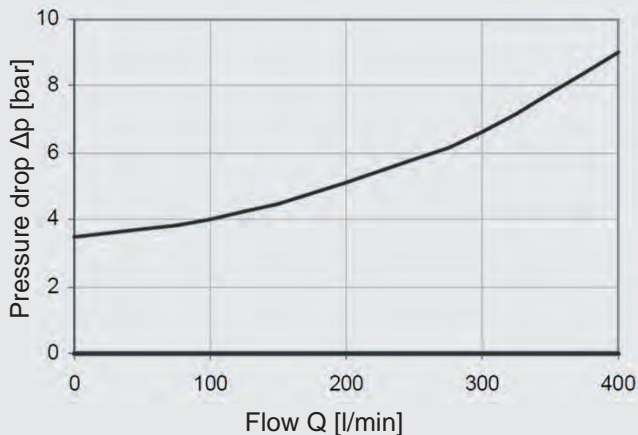

P-Q performance

measured at $v = 36 \text{ mm}^2/\text{s}$ and $T_{oil} = 50^\circ\text{C}$

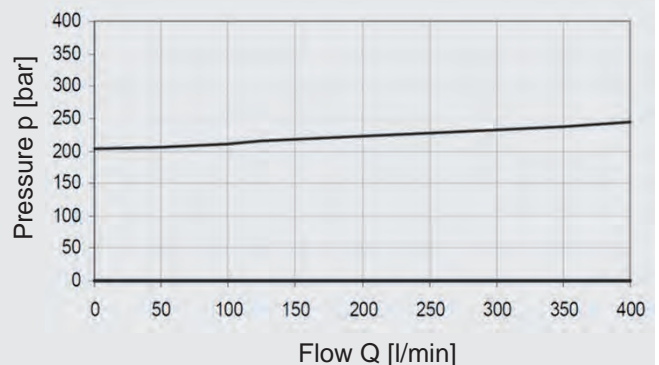

DIMENSIONS

Interface according to ISO 6264-08-13-*⁻⁹⁷ (Cetop 4.4.2-2-R08-350)

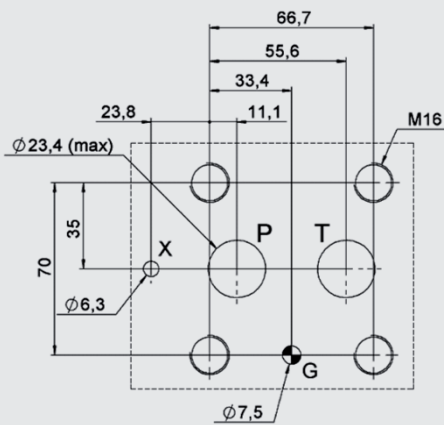

Mounting screws

(not included in delivery)
DIN EN ISO 4762 - M16x50 – 10.9
Tightening torque: 170 Nm

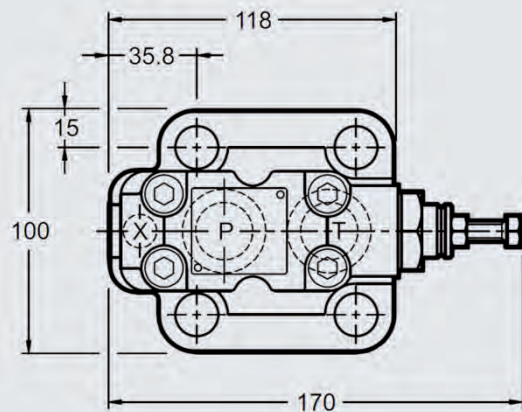
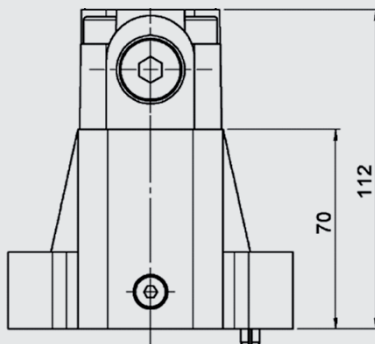
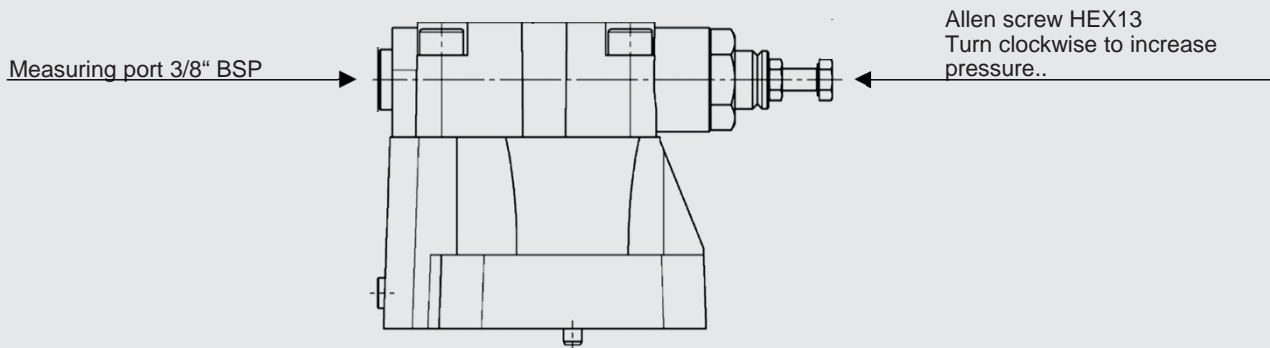

Note

The information in this brochure relates to the operating conditions and applications described. For applications not described, please contact the relevant technical department. All technical details are subject to change without notice.

HYDAC Fluidtechnik GmbH

Justus-von-Liebig-Str.

D-66280 Sulzbach/Saar

Tel: 0 68 97 /509-01

Fax: 0 68 97 /509-598

E-Mail: valves@hydac.com

Proportional pressure relief valve direct-acting VP-PDB6

DESCRIPTION

HYDAC direct-acting proportional pressure relief valves limit pressure in meter-in in the system or control the power build-up in meter-out in hydraulic actuators.

For electrical control of the coil there are electronic controls available (see brochure see brochure 2.429.2).

FEATURES

- Interface according to ISO 4401-03-02-0-05 (Cetop 4.2-4-03-350)
- Performance limits can be completely realized
- Electronic control by EHCD (see brochure 2.429.2)

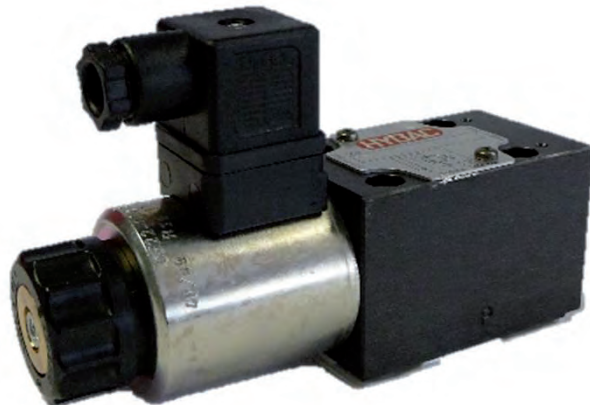

Nominal size 6
up to 2 l/min
up to 350 bar

CONTENT

Description

Features

Model code

Spool types / Symbols

Accessories

Function

Section view

Technical Data

Performance

Dimensions

MODEL CODE

VP-PDB 6 070 D01 – 24 PG / N

Type

Proportional pressure relief valve, direct-acting

Nominal size

6

Pressure range

025 = 0,9 up to 25 bar
 070 = 1,6 up to 70 bar
 140 = 2,4 up to 140 bar
 210 = 3,2 up to 210 bar
 350 = 5,0 up to 350 bar

Series

D01 = standard

Rated voltage of the solenoid coil

24 = 24 VDC

Coil type

PG = Proportional device connector

Sealing material

V = FKM
 N = NBR

SPOOL TYPES / SYMBOLS

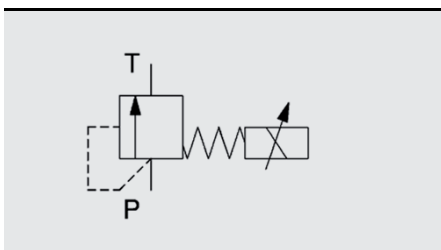

ACCESSORIES

	Designation	Part no.
Seal kits (2-part set)	9,25 x 1,78 -FKM -90 Sh	3526091
	9,25 x 1,78 -NBR -90 Sh	3526088
Mounting screws (4 pcs)	DIN EN ISO 4762-M5x30-10.9	603227

FUNCTION

The VP-PDB6 is a direct-acting proportional pressure relief valve.

If the pressure at port P exceeds the spring force, the valve opens and oil flows to tank port T. The spring force is directly dependent on the solenoid force and thereby on the control current, enabling a continuous adjustment of the limiting depending on the control current.

Attention:

Pressures at tank port T are added to the setting value.

SECTION VIEW

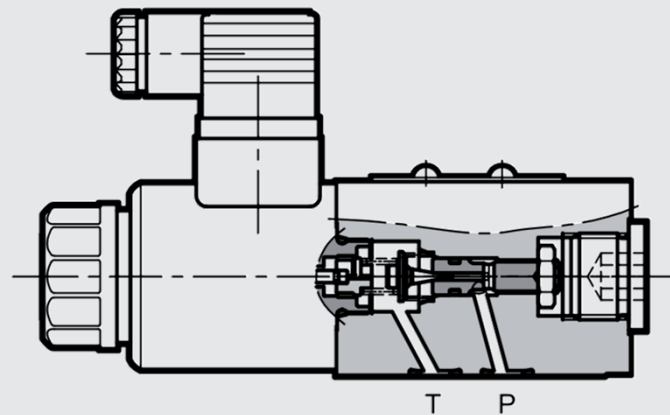

TECHNICAL DATA ¹

General specifications			
MTTF _d :		According to EN ISO 13849-1:2015 chart C1 & C2	
Ambient temperature:	[°C]	-20 to +60	
Installation position:		No orientation restrictions	
Weight:	[kg]	1,5	
Material:		Valve casing:	Cast iron
		Name plate:	Aluminium
Surface coating:		Valve casing:	Phosphate plated
Hydraulic specifications			
Operating pressure:	[bar]	Port P:	p _{max} = 350
		Port T:	p _{max} = 2
Pressure range:	[bar]	0,9 up to 25 1,6 up to 70 2,4 up to 140 3,2 up to 210 5,0 up to 350	
Volume flow:	[l/min]	2	
Operating fluid:		Hydraulic oil to DIN 51524 part 1, 2 and 3	
Media operating temperature range:	[°C]	-20 to +80	
Viscosity range:	[mm ² /s]	10 – 400 (25 is recommended)	
Permitted contamination level of operating fluid:		class 18/16/13 to ISO 4406	
Sealing material:		FKM, NBR	
Electrical specifications			
Switching time:	[ms]	On:	ca. 60 (0 – 100%)
		Off:	ca. 70 (100 - 0%)
Type of voltage:		DC	
Rated voltage:	[V]	24	
Resistance at 20°C :	[Ω]	17,6	
Rated current:	[A]	0,86	
Duty cycle:	[%]	100	
Hysteresis:	[%]	< 5 of p _{nom}	
Repeatability:	[%]	±1,5 of p _{nom}	
Protection class to DIN EN 60529:	[°C]	with electrical connection "G" IP65 ²	

¹ see „Conditions and Instructions for Valves“ in brochure 53.000

² if installed correctly

PERFORMANCE

measured at $v = 36 \text{ mm}^2/\text{s}$ and $T_{\text{oil}} = 50^\circ\text{C}$

Pressure reducing diagram $p = f(I)$ ($Q = 1 \text{ l/min}$ factory setting)

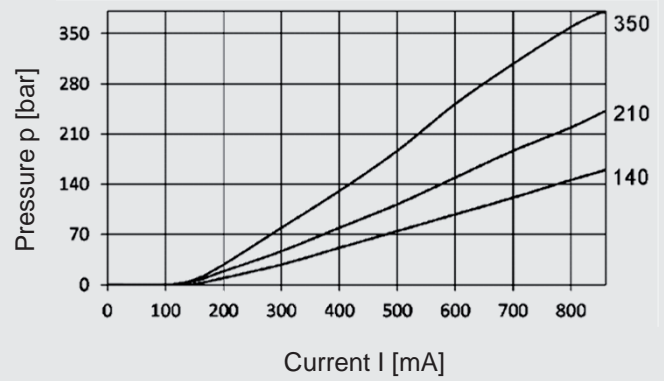
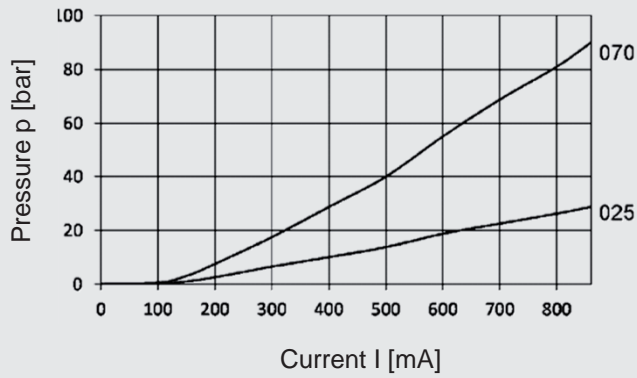

Flow $p_{\text{min}} = f(Q)$

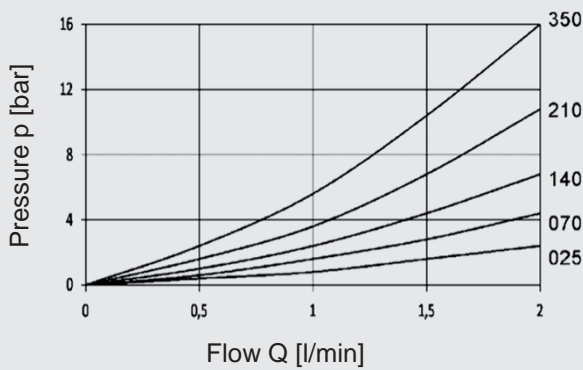

Pressure changes $p_{\text{max}} = f(Q)$

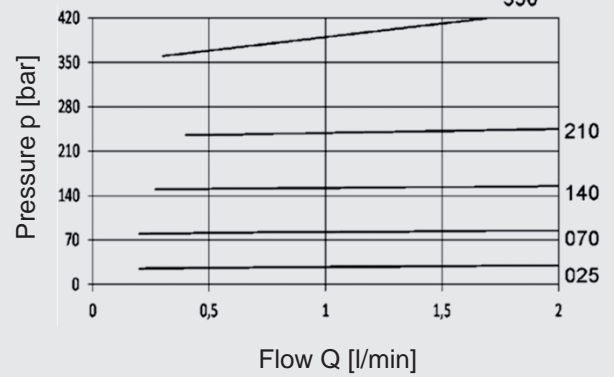

DIMENSIONS

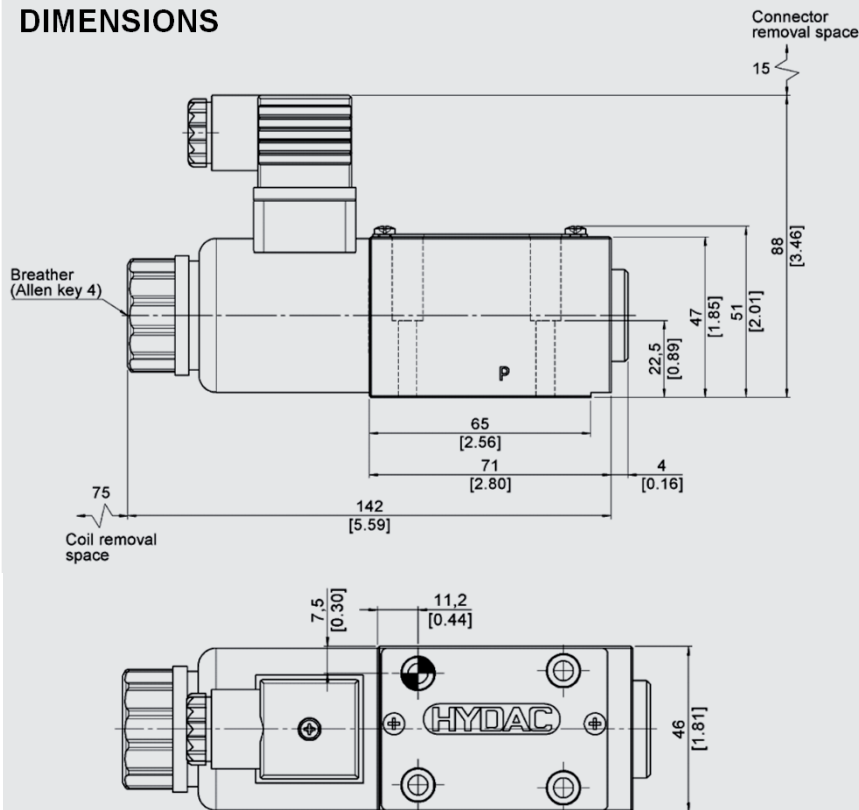

Interface to ISO 4401-03-02-0-05
(Cetop 4.2-4-03-350)

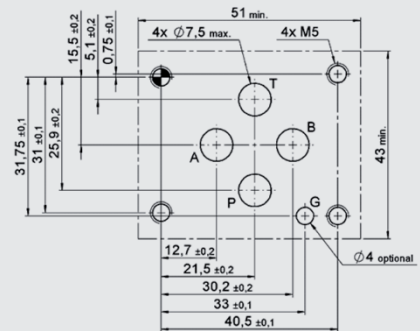

Mounting screws

(not included in delivery)
DIN EN ISO 4762 – M5x30 – 10.9
Tightening torque: 5 Nm

Note

The information in this brochure relates to the operating conditions and applications described. For applications not described, please contact the relevant technical department.

All technical details are subject to change without notice.

HYDAC Fluidtechnik GmbH

Justus-von-Liebig-Str.

D-66280 Sulzbach/Saar

Tel: 0 68 97 /509-01

Fax: 0 68 97 /509-598

E-Mail: valves@hydac.com

Proportional flow regulator pressure compensated, direct-acting VP-P2SRE6

DESCRIPTION

HYDAC direct-acting flow control valves are 2-way proportional valves, which keep the required volume flow constant due to a control process. The volume flow is largely independent of pressure and viscosity.

The valve consists of a pressure compensator and a proportionally adjustable orifice.

For electrical control of the coil there are electronic controls available (see brochure 2.429.2).

FEATURES

- Interface according to ISO 6263-03-03-0-97 (Cetop 4.5.2-2-03-250)
- Small hysteresis by superfinish of moving parts
- Electronic control by EHCD (see brochure 2.429.2)



Nominal size 6
up to 25 l/min
up to 250 bar

CONTENT

Description

Features

Model code

Spool types / Symbols

Accessories

Function

Section view

Technical Data

Performance

Dimensions

MODEL CODE

VP-P2SRE 6 L 16 R D01 - 24 PG / V

Type

Proportional flow control valve, direct-acting

Nominal size

6

Performance

L = linear

Nominal volume flow

01 = 1,5 l/min

04 = 4 l/min

08 = 8 l/min

16 = 16 l/min

25 = 25 l/min

Check valve

R = Check valve

Series

D01 = standard

Rated voltage of the solenoid coil

24 = 24 VDC

Coil type

PG = Proportional device connector

Sealing material

V = FKM (standard)

N = NBR

SPOOL TYPES / SYMBOLS

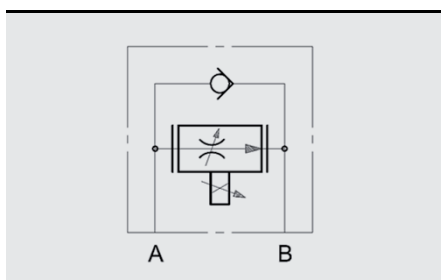

ACCESSORIES

	Designation	Part no.
Seal kits (2-part set)	14 x 2 -FKM -90 Sh	3526085
	14 x 2 -NBR -90 Sh	3526072
Mounting screws (4 pcs)	DIN EN ISO 4762-M5x70-10.9	615551

FUNCTION

The VP-P2SRE6 is a direct-acting 2-way flow control valve, which controls volume flow from port A to port B independently of the pressure. In the opposite direction there is free flow through the check valve without control.

The controlled flow rate is proportional to the electrical input signal at the coil. Analogue to the size the coil creates a force which pushes the piston against the spring. Hereby opening diameters are opened which determine the size of the flow independent from the pressure differential.

A built-in pressure compensator enables the regulation independent from pressure changes from port A to B.

For electronic control of the coil there are electronic controls available (see brochure 5.249.2).

Hint:

Bleed system and valve before setting in motion.

SECTION VIEW

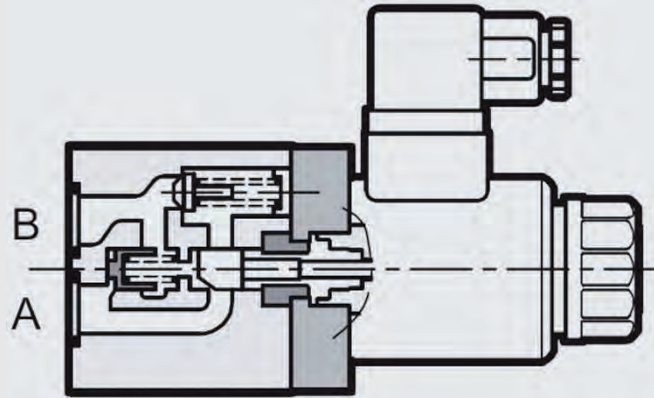

TECHNICAL DATA ¹

General specifications

MTTF _d :	According to EN ISO 13849-1:2015 chart C1 & C2		
Ambient temperature:	[°C]	-20 to +50	
Installation position:	No orientation restrictions		
Weight:	[kg]	1,5	
Material:	Valve casing:	Cast iron	
	Name plate:	Aluminium	
Surface coating:	Valve casing:	Phosphate plated	

Hydraulic specifications

Operating pressure:	[bar]	Port A, B:	$p_{max} = 250$
Volume flow range: (at Δp A → B min. 10 bar)	[l/min]	0 up to 1,5 0 up to 4 0 up to 8 0 up to 16 0 up to 25 (40 in opposite direction B → A)	
Operating fluid:	Hydraulic oil to DIN 51524 part 1, 2 and 3		
Media operating temperature range:	[°C]	-20 to +80	
Viscosity range:	[mm ² /s]	10 – 400 (25 is recommended)	
Permitted contamination level of operating fluid:	class 18/16/13 to ISO 4406 or 17/15/12 for flows < 0,5 l/min		
Sealing material:	NBR, FKM (standard)		

Electrical specifications

Switching time:	[ms]	On: 60 (0 - 100%); 50 (25 - 75%) Off: 80 (100 - 0%); 70 (75 - 25%)	
Type of voltage:	DC		
Rated voltage:	[V]	24	
Rated current:	[A]	0,86	
Resistance at 20°C	[Ω]	17,6	
Duty cycle:	[%]	100	
Hysteresis:	[%]	< 6 of Q_{max}	
Repeatability:	[%]	±2,5 of Q_{max}	
Protection class to DIN EN 60529:	with electrical connection "G" IP65 ²		

¹ see „Conditions and Instructions for Valves“ in brochure 53.000

² if installed correctly

PERFORMANCE

measured at $v = 36 \text{ mm}^2/\text{s}$ and $T_{\text{oil}} = 50^\circ\text{C}$

Flow control $Q = f(I)$

from port A \rightarrow B

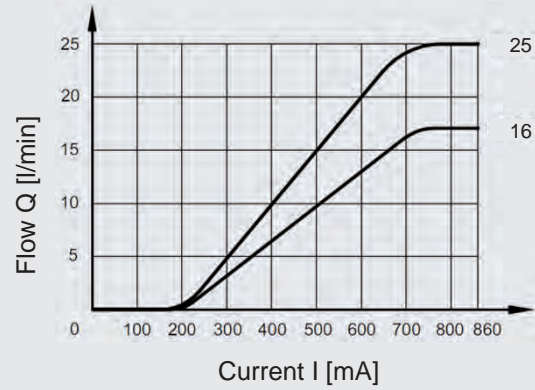
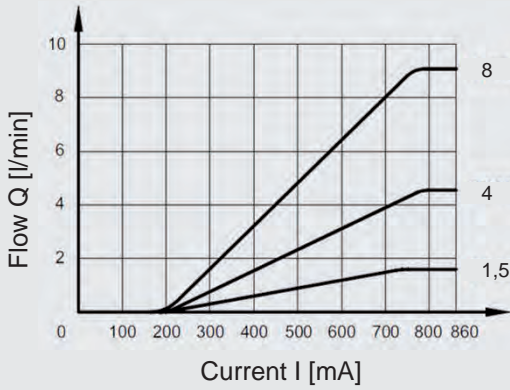

Pressure drop $\Delta p = f(Q)$

with free flow from port B \rightarrow A through the check valve

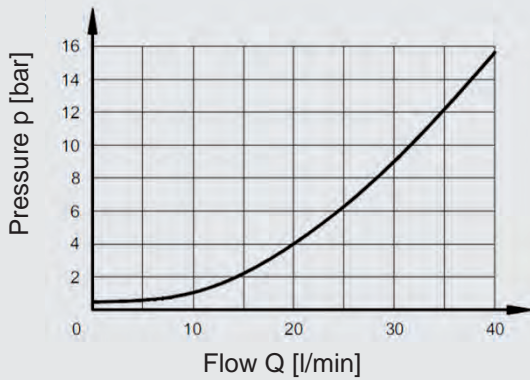

DIMENSIONS

Interface according to ISO 6263-03-03-0-97

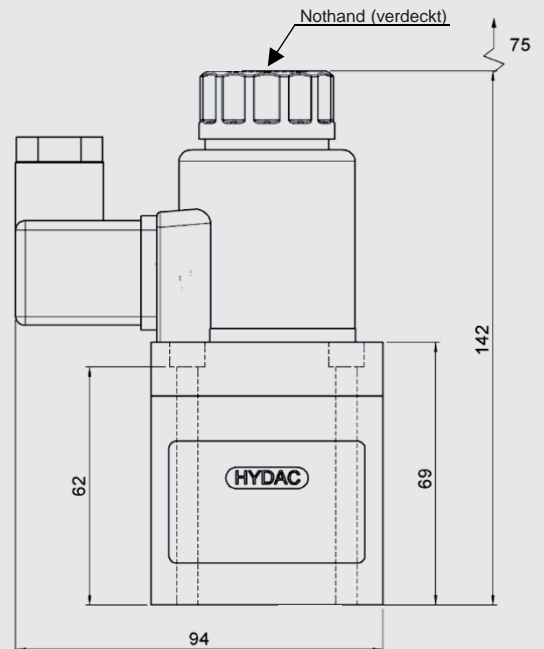
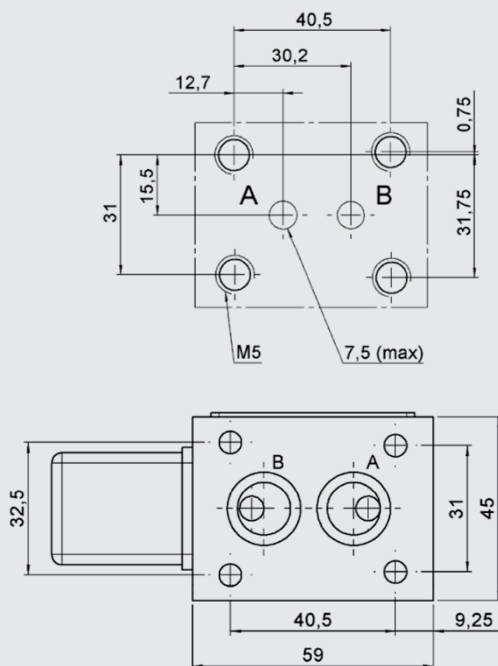

Mounting screws

(not included in delivery)
DIN EN ISO 4762 – M5x70 – 10.9
Tightening torque: 5 Nm

Note

The information in this brochure relates to the operating conditions and applications described. For applications not described, please contact the relevant technical department.

All technical details are subject to change without notice.

HYDAC Fluidtechnik GmbH

Justus-von-Liebig-Str.
D-66280 Sulzbach/Saar
Tel: 0 68 97 /509-01
Fax: 0 68 97 /509-598
E-Mail: valves@hydac.com

Proportional flow regulator pressure compensated, direct-acting with transducer

VP-P2SRR6

DESCRIPTION

HYDAC direct-acting flow control valves are 2-way proportional valves with transducer.

The valve keeps the required volume flow constant due to a control process. The volume flow is largely independent of pressure and viscosity.

The valve consists of a pressure compensator and a proportionally adjustable orifice.

For electrical control of the coil there are electronic controls available (see brochure see brochure 2.429.2).

FEATURES

- Interface according to ISO 6263-03-03-0-97 (Cetop 4.5.2-2-03-250)
- Small hysteresis by superfinish of moving parts
- Electronic control by EHCD (see brochure 2.429.2)



Nominal size 6
up to 25 l/min
up to 250 bar

CONTENT

Description

Features

Model code

Spool types / Symbols

Accessories

Function

Section view

Technical Data

Performance

Transducer

Dimensions

MODEL CODE

VP-P2SRR 6 L 16 R D01 - 24 PG / V

Type

Proportional flow control valve with transducer, direct-acting

Nominal size

6

Performance

L = linear

Nominal volume flow

01 = 1,5 l/min
 04 = 4 l/min
 08 = 8 l/min
 16 = 16 l/min
 25 = 25 l/min

Check valve

R = Check valve

Series

D01 = standard

Rated voltage of the solenoid coil

24 = 24 VDC

Coil type

PG = Proportional device connector

Sealing material

V = FKM (standard)
 N = NBR

SPOOL TYPES / SYMBOLS

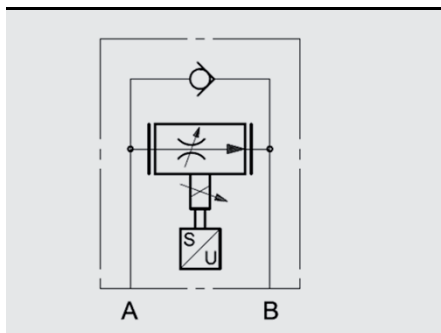

ACCESSORIES

	Designation	Part no.
Seal kits (2-part set)	14 x 2 -FKM -90 Sh	3526085
	14 x 2 -NBR -90 Sh	3526072
Mounting screws (4 pcs)	DIN EN ISO 4762-M5x65-10.9	688208

FUNCTION

The VP-P2SRR 6 is a direct-acting 2-way flow control valve with transducer.

The proportional valve controls volume flow from port A to port B independently of the pressure. In the opposite direction there is free flow through the check valve without control.

The controlled flow rate is proportional to the electrical input signal at the coil. Analogue to the size the coil creates a force which pushes the piston against the spring. Hereby opening diameters are opened which determine the size of the flow independent from the pressure differential.

A built-in pressure compensator enables the regulation independent from pressure changes from port A to B.

For electrical control of the coil there are electronic controls available (see brochure 5.249.4).

Hint:

Bleed system and valve before setting in motion.

Transducer

The VP-P2SRR6 valve uses an LVDT type position transmitter with an amplified signal that allows precise control of the position of the throttle, and therefore of the regulated flow. This improves repeatability and hysteresis. The position transmitter is mounted coaxially to the proportional solenoid coil. The DIN connector can be moved 360°. The position transmitter is protected against polarity inversion on the power line.

SECTION VIEW

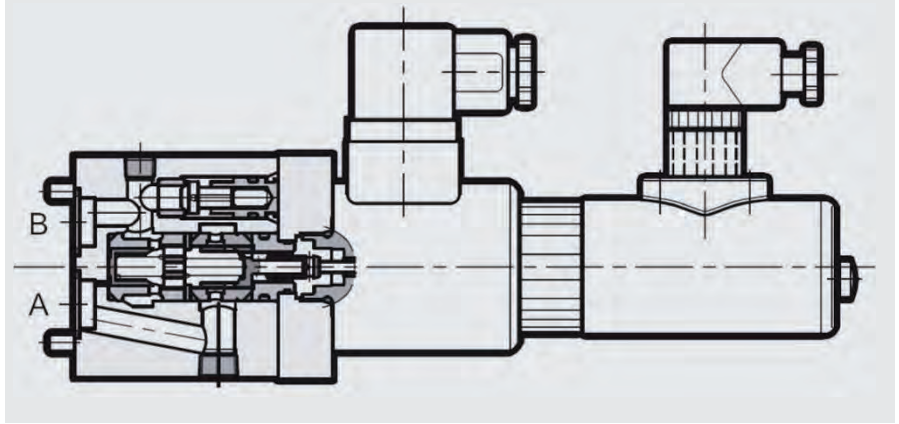

TECHNICAL DATA ¹

General specifications

MTTF _d :	According to EN ISO 13849-1:2015 chart C1 & C2		
Ambient temperature:	[°C]	-10 to +50	
Installation position:	No orientation restrictions		
Weight:	[kg]	2,2	
Material:	Valve casing:	Cast iron	
	Name plate:	Aluminium	
Surface coating:	Valve casing:	Phosphate plated	

Hydraulic specifications

Operating pressure :	[bar]	Port A, B:	$p_{max} = 250$
Volume flow range :	[l/min]	0 up to 1,5	
(at Δp A → B min. 10 bar)		0 up to 4	
		0 up to 8	
		0 up to 16	
		0 up to 25	
		(40 in opposite direction B → A)	
Operating fluid:	Hydraulic oil to DIN 51524 part 1, 2 and 3		
Media operating temperature range:	[°C]	-20 to +80	
Viscosity range:	[mm ² /s]	10 – 400 (25 is recommended)	
Permitted contamination level of operating fluid:	class 18/16/13 to ISO 4406 or 17/15/12 for flows < 0,5 l/min		
Sealing material:	NBR, FKM (standard)		

Electrical specifications

Switching time:	[ms]	On: 180 (0 - 100%) 150 (25 - 100%) Off: 150 (100 - 0%) 120 (100 - 25%)
Type of voltage:	DC	
Rated voltage:	[V]	24
Rated current:	[A]	0,86
Resistance at 20°C	[Ω]	17,6
Duty cycle:	[%]	100
Hysteresis:	[%]	< 2,5 of Q_{max}
Repeatability:	[%]	< ±1 of Q_{max}
Protection class to DIN EN 60529:	with electrical connection "G" IP65 ²	

¹ see „Conditions and Instructions for Valves“ in brochure 53.000

² if installed correctly

PERFORMANCE

measured at $v = 36 \text{ mm}^2/\text{s}$ and $T_{\text{oil}} = 50^\circ\text{C}$

Flow control $Q = f(I)$
from port A \rightarrow B

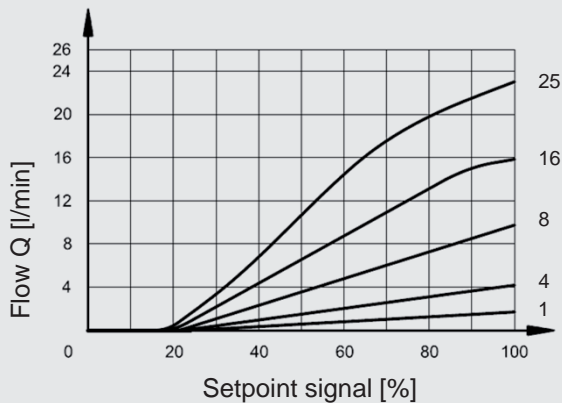

Pressure drop $\Delta p = f(Q)$

with free flow from port B \rightarrow A through the check valve

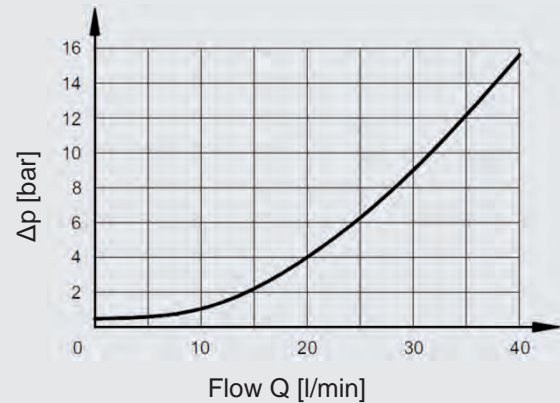

TRANSDUCER

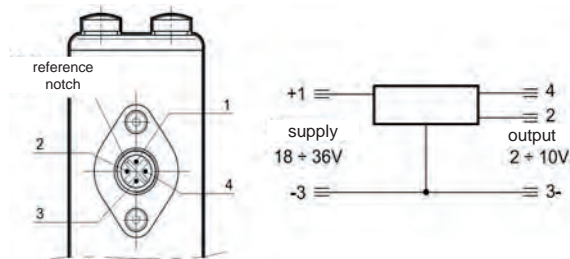

Transducer connection		Electronic card connection
PIN 1	Versorgung 18 ÷ 36 V	PIN 8c
PIN 2	Ausgang 2 ÷ 10 V	PIN 24a
PIN 3	0 V	PIN 22c
PIN 4	NC	NC

DIMENSIONS

Interface according to ISO 6263-03-03-0-97

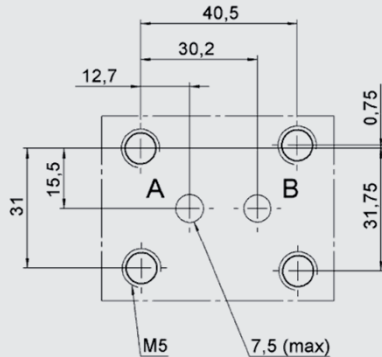

Mounting screws

(not included in delivery)
DIN EN ISO 4762 – M5x65 – 10.9
Tightening torque: 5 Nm

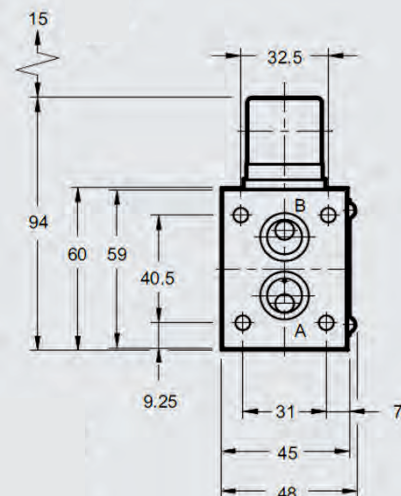
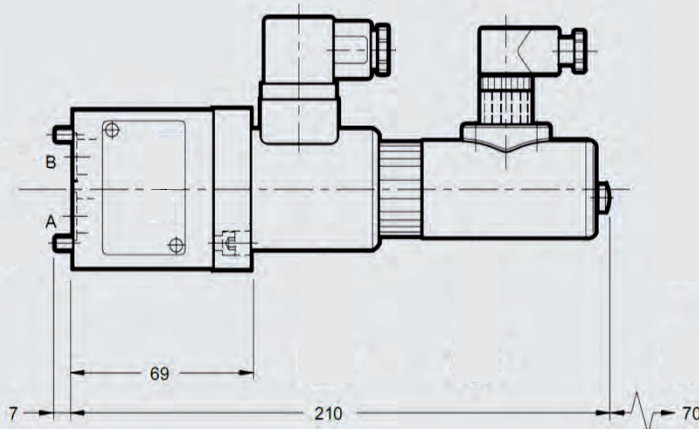

Note

The information in this brochure relates to the operating conditions and applications described. For applications not described, please contact the relevant technical department.

All technical details are subject to change without notice.

HYDAC Fluidtechnik GmbH

Justus-von-Liebig-Str.

D-66280 Sulzbach/Saar

Tel: 0 68 97 /509-01

Fax: 0 68 97 /509-598

E-Mail: valves@hydac.com

Cartridge valves L-CEE 16 to 80

DESCRIPTION

HYDAC 2-way cartridge valves are logic valves that are used in hydraulic control systems with high performance requirements.

Our series can be adapted to the size of your system and covers the nominal sizes 16, 25, 32, 40, 50, 63 and 80.

The cartridge valves are available for directional and pressure functions with the options of damping pins and shaft seals.

You can find a control cover to match your cartridge valve in the brochure 5.249.30 "Control cover LD-CCE for 2-way cartridge valves".

FEATURES

- Available with optional damping pins and shaft seals for directional and pressure functions
- Flow-optimised and robust design
- Low pressure losses
- Interface to ISO 7368



up to 10800 l/min
up to 420 bar

CONTENTS

Description

Features

Model code

Cracking pressure

Poppet types

Installation instructions

Technical Data

Directionalfunction

Pressurefunction

Dimensions

Accessories

MODEL CODE

L-CEE 16 H 6 B X - 10 / N

Type

2-way cartridge valve

Nominal size (NG)

16, 25, 32, 40, 50, 63, 80

Design

H = 420 bar

Series

Cavity to ISO 7368

Symbol

A = cone 1:1

B = cone 1:1,5

C = cone 1:1,5

E = cone 1:1,07

F = cone 1:1,07

Sealing options

Not specified = no shaft seal

X = with shaft seal (not available for poppet A)

Spring

10 = 1 bar (cracking pressure x 10)

see chart "Cracking pressures"

Sealing material

N = NBR (standard)

V = FKM

CRACKING PRESSURES

Poppet types	Nominal size						
	16	25	32	40	50	63	80
A	1,0	1,0	1,0	0,7	0,7	0,7	0,7
	2,0	2,0	2,0	1,4	1,4	1,5	1,4
	4,0	4,0	4,0	2,9	2,9	2,9	2,8
B	1,0	1,0	1,0	1,0	1,0	1,0	1,0
	1,9	2,1	2,0	2,0	2,0	2,0	2,0
	3,8	4,2	4,0	4,0	4,0	4,0	4,0
BX	3,8	4,2	4,0	4,0	4,0	4,0	4,0
C	1,0	1,0	1,0	1,0	1,0	1,0	1,0
	1,9	2,1	2,0	2,0	2,0	2,0	2,0
	3,8	4,2	4,0	4,0	4,0	4,0	4,0
CX	3,8	4,2	4,0	4,0	4,0	4,0	4,0
E	0,7	0,7	0,7	0,7	0,7	0,7	0,7
	1,4	1,5	1,4	1,4	1,4	1,4	1,4
	2,7	3,0	2,8	2,9	2,9	2,9	2,8
EX	2,7	3,0	2,8	2,9	2,9	2,9	2,8
F	0,7	0,7	0,7	0,4	0,7	0,7	0,7
	1,4	1,5	1,4	1,4	1,4	1,4	1,4
	2,7	3,0	2,8	2,9	2,9	2,9	2,8
FX	2,7	3,0	2,8	2,9	2,9	2,9	2,8

Hint: All poppet types with shaft seals should be used with the strongest available spring. These springs guarantee that the poppet will close securely against the friction force of the seal.

POPPET TYPES

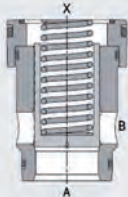
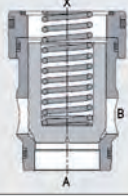
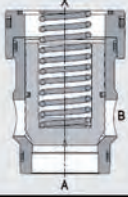
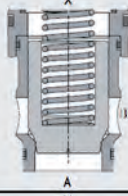
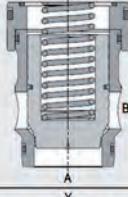
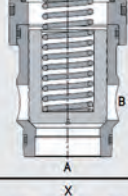
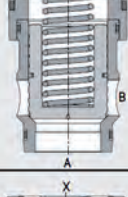
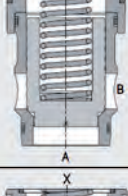
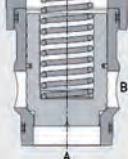
Type	Section view	Area ratio	Description
A		1 : 1	<ul style="list-style-type: none"> • standard • pressure function
B		1 : 1,5	<ul style="list-style-type: none"> • standard • directional function
BX		1 : 1,5	<ul style="list-style-type: none"> • with shaft seal • directional function
C		1 : 1,5	<ul style="list-style-type: none"> • with damping • directional function
CX		1 : 1,5	<ul style="list-style-type: none"> • with damping and shaft seal • directional function
E		1 : 1,07	<ul style="list-style-type: none"> • standard • directional function / pressure function
EX		1 : 1,07	<ul style="list-style-type: none"> • with shaft seal • directional function / pressure function
F		1 : 1,07	<ul style="list-style-type: none"> • with damping • directional function
FX		1 : 1,07	<ul style="list-style-type: none"> • with damping and shaft seal • directional function

INSTALLATION INSTRUCTIONS

Seals

The external seals should be lightly greased before installation and checked for correct fit after installation. The backup rings must not protrude beyond the external diameter of the sleeves. If necessary, remove the backup rings, preload to a smaller diameter and then re-install.

Orientation in the manifold

For optimal use of the logic valve in the manifold, two possible installation positions are available depending on the number of holes in the sleeve:

- Sleeves with six lateral holes must be installed with the web towards the B port. Consequently, two holes of the sleeve are directed to the hole in the control manifold.
- Sleeves with four lateral holes must be positioned so that one hole in the sleeve is concentric with the hole in the control manifold.

Installation position of sleeves with 6 holes:

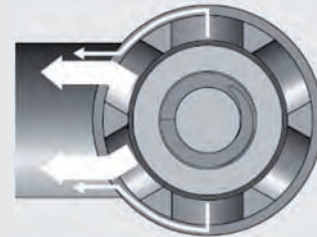

Installation position of sleeves with 4 holes:

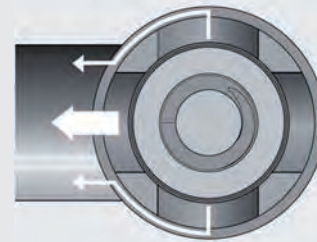

TECHNICAL DATA

General specifications								
		Nominal size						
		16	25	30	40	50	63	80
MTTFd		To EN ISO 13849-1:2015 chart C1 & C2						
Ambient temperature	[°C]	NBR: -30 to +80 FKM: -20 to +80						
Installation position		No orientation restrictions						
Weight	[kg]	0,17	0,40	0,90	1,80	3,20	6,90	12
Material		Valve casing: steel (burnished)						
Interface ISO7368		BA-06-2-A	BB-08-2-A	BC-09-2-A	BD-10-2-A	BE-11-2-A	BF-12-2-A	BG-13-2-A
Hydraulic specifications								
		Nominal size						
		16	25	30	40	50	63	80
Operating pressure	[bar]	420						
Flow rate	[l/min]	600	1000	1600	2800	4700	7900	10800
Flow rate direction		A ↔ B (A → B)						
Poppet stroke	[mm]	9	13 9 (poppet A)	15	20	24	28	32
Control volume	[m ³]	2,83 1,81 (poppet A)	9,19 4,42 (poppet A)	17,92 12,06 (poppet A)	33,24 31,11 (poppet A)	67,86 63,41 (poppet A)	133,79 123,70 (poppet A)	203,58 190,23 (poppet A)
Operating fluid		Hydraulic oil to DIN 51524 part 1, 2 and 3						
Temperature range of operating fluid	[°C]	NBR: -30 to +80 FKM: -20 to +80						
Viscosity	[mm ² /s]	2,8 to 380						
Permitted contamination level of operating fluid		class 20/18/15 to ISO 4406						
Sealing material		NBR (standard), FKM						

2-way cartridge valves

Directional function

FUNCTION

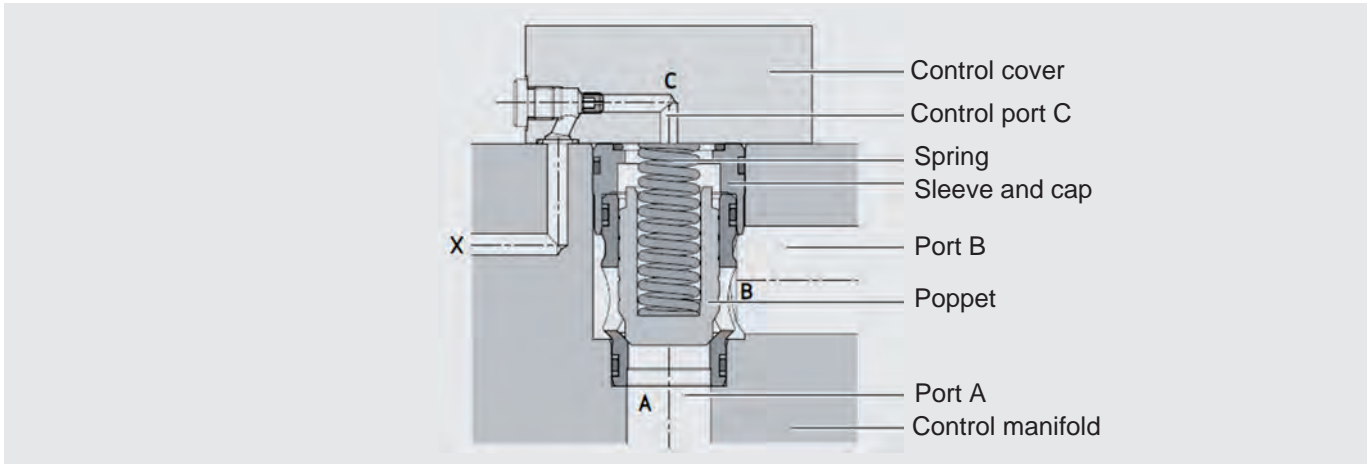

HYDAC 2-way cartridge valves with poppets B(X), C(X), E(X) and F(X) are used for directional functions.

The valve is installed in a standardised cartridge hole (ISO 7368). In combination with a control cover and pilot valve results in a switch or check function, for example.

The valve switches or is closed depending on the pressure ratio between the control areas A_A , A_B , A_X . In normal position, the springs acting in the closing direction causes leaktight closing of the working ports A and B via the valve poppet.

Flow from port A → B or B → A by loading the valve with suitable pressurization.

SYMBOLS

B	C	E	F
BX	CX	EX	FX

2-way cartridge valves

Directional function

REFERENCE AREA

Poppet type	NG	Reference area A_A [mm ²]	Factor A_A	Factor A_B	Factor A_X
B(X) C(X)	16	209	1	0,5	1,5
	25	471			
	32	794			
	40	1110			
	50	1886			
	63	3187			
E(X) F(X)	16	290	1	0,07	1,07
	25	661			
	32	1116			
	40	1555			
	50	2642			
	63	4465			
	80	5945			

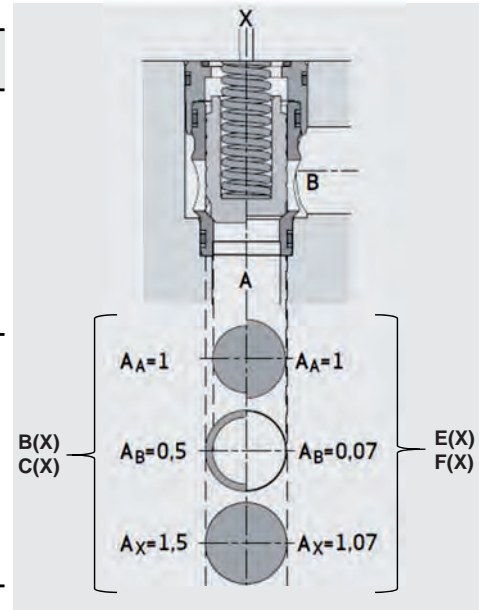

PERFORMANCE

measured at $v = 32 \text{ mm}^2/\text{s}$ and $T = 40^\circ\text{C}$

NG16

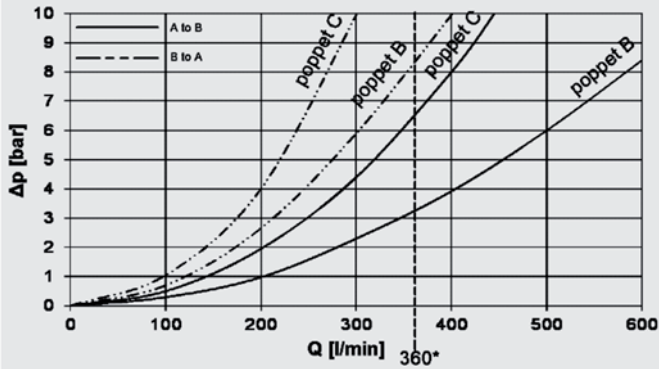

NG25

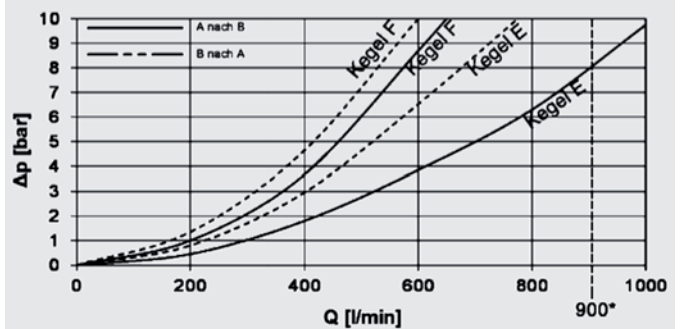
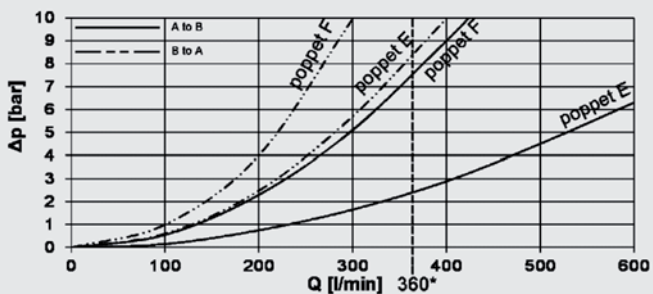
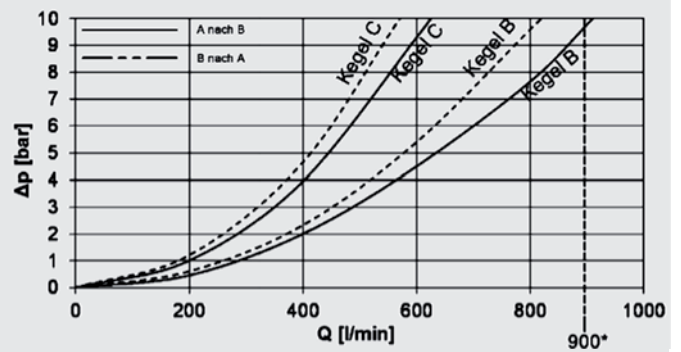

PERFORMANCE

measured at $v = 32 \text{ mm}^2/\text{s}$ and $T = 40^\circ\text{C}$

NG32

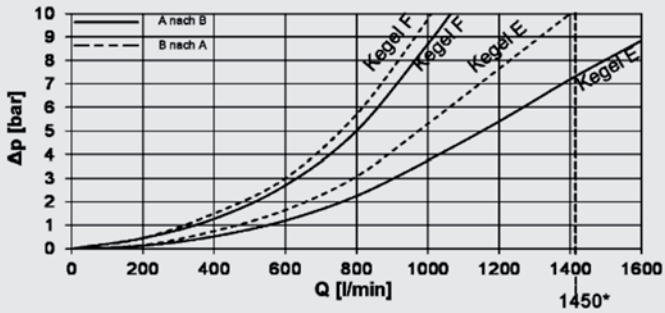
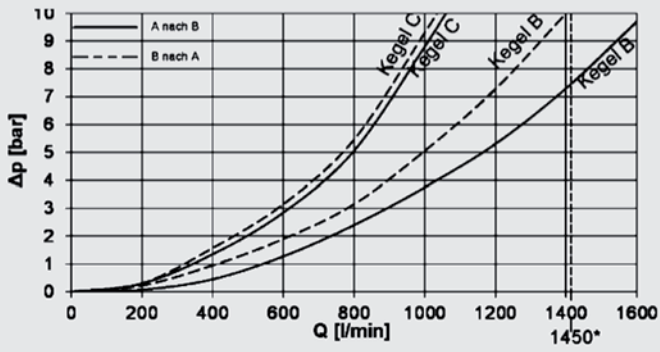

NG40

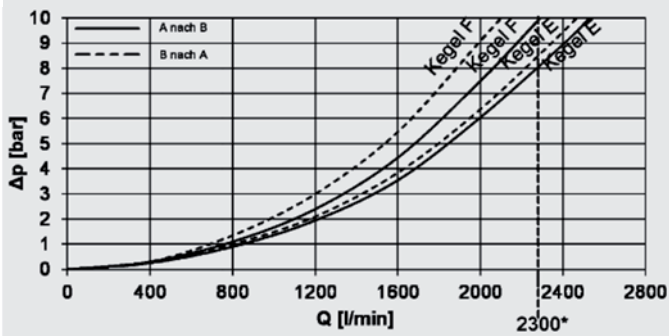
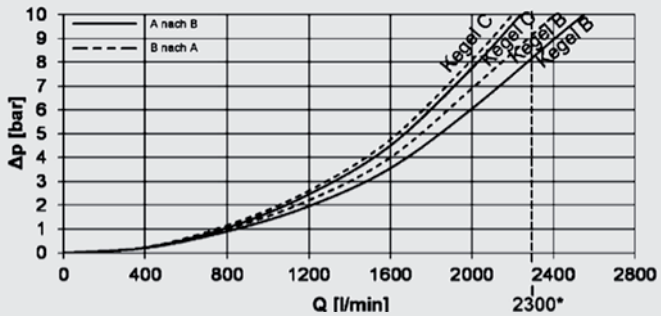

NG50

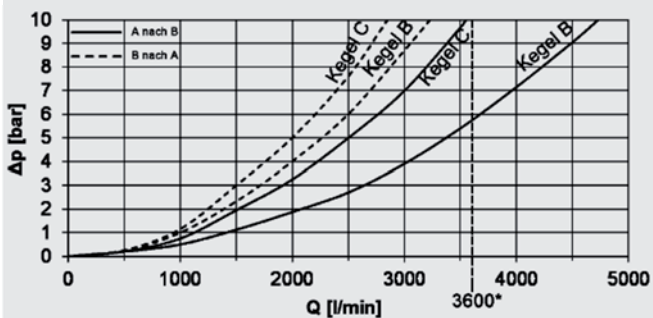

NG50

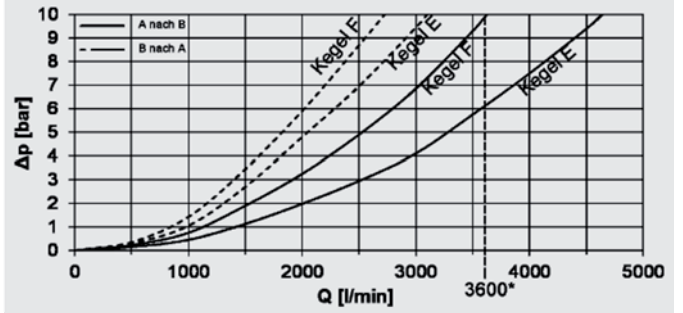

NG63

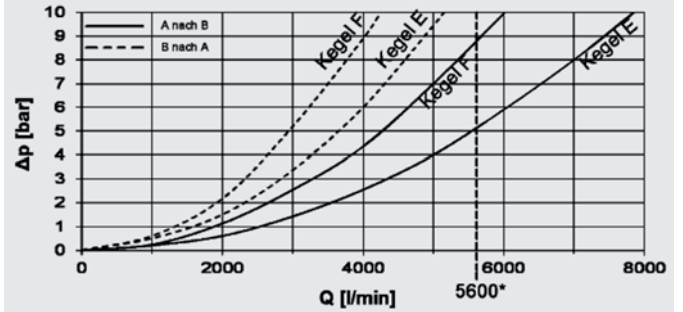
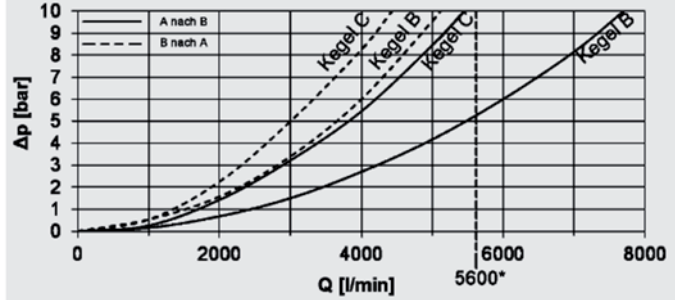

NG80

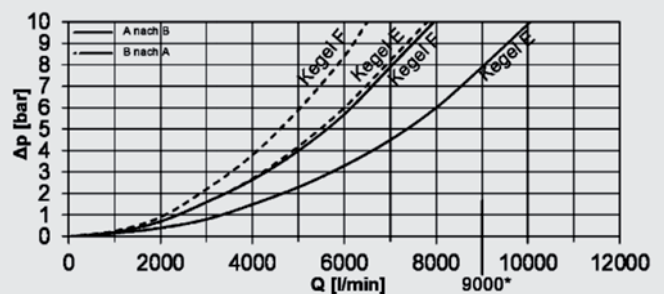
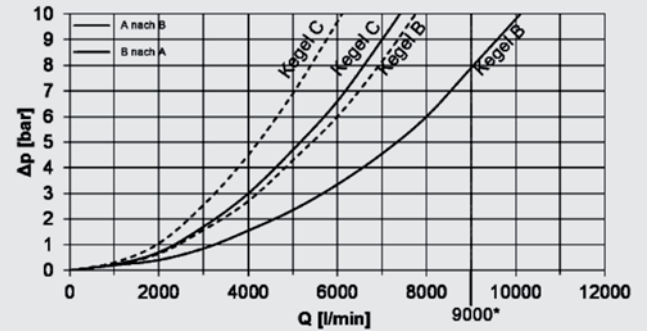

2-way cartridge valves

Pressure function

FUNCTION

HYDAC 2-way cartridge valves with poppets A and EX are used for pressure functions, for example as pump or cylinder safeguarding.

The valve is installed in a standardised cartridge hole (ISO 7368). In combination with a control cover and pilot valve results in manual or electric-proportional pressure settings with and without electric relief.

The control area at port B is significantly smaller than for the directional function. Port C is loaded with pressure via control port from port A. The pressure at port A is also present at the pilot valve.

If the pressure in port A exceeds the setting pressure at the pilot valve, it opens. The control area at port C is loaded with pressure, so the poppet lifts from the valve seat and thus limit the pressure at port A.

SYMBOLS

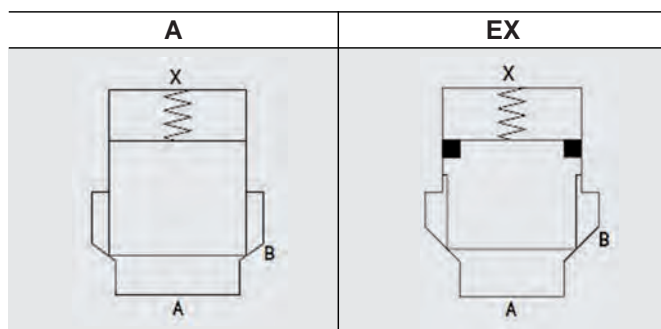

REFERENCE AREA

Poppet type	NG	Reference area A_A [mm ²]	Factor A_A	Factor A_B	Factor A_X
A	16	201	1	0	1
	25	491			
	32	804			
	40	1555			
	50	2642			
	63	4418			
EX	16	290	1	0,07	1,07
	25	661			
	32	1116			
	40	1555			
	50	2642			
	63	4465			
	80	5945			

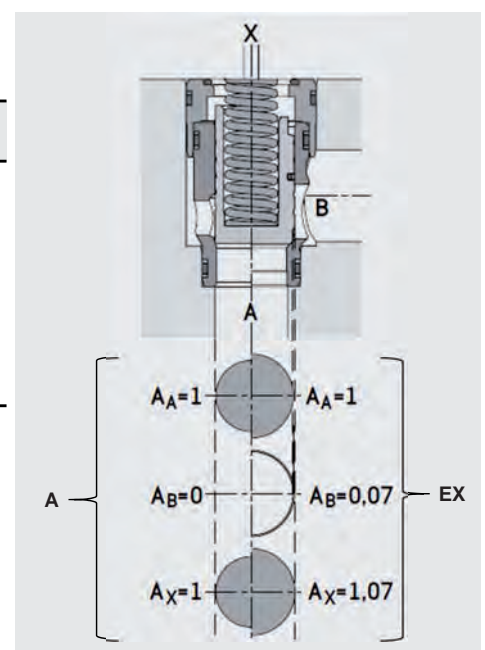

PERFORMANCE

measured at $v = 32 \text{ mm}^2/\text{s}$ and $T = 40^\circ\text{C}$

NG16

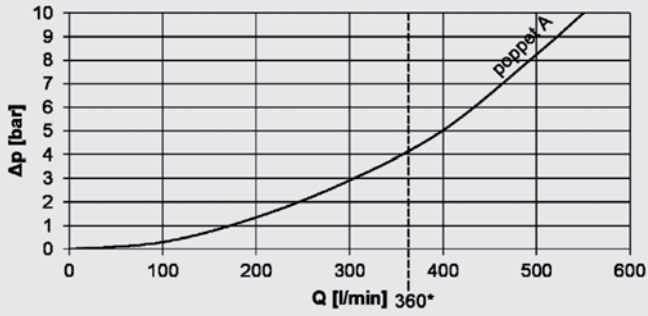

NG50

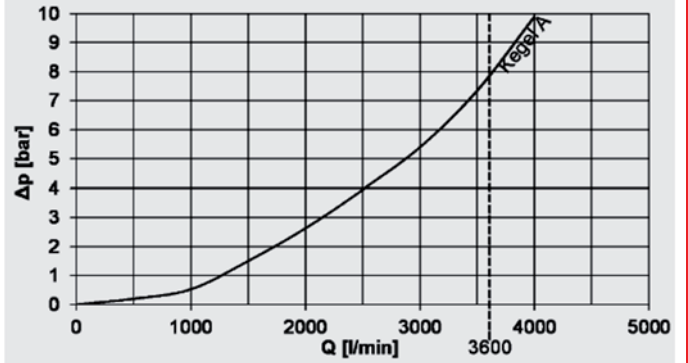

NG25

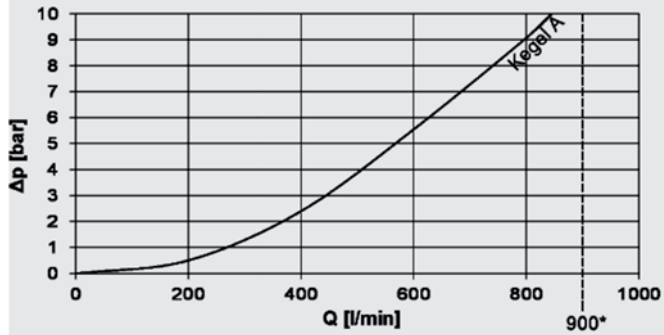

NG63

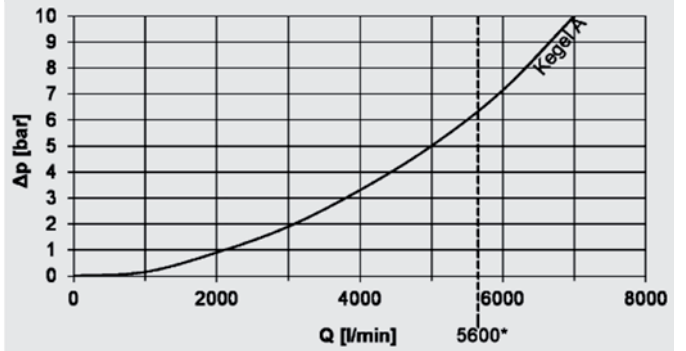

NG32

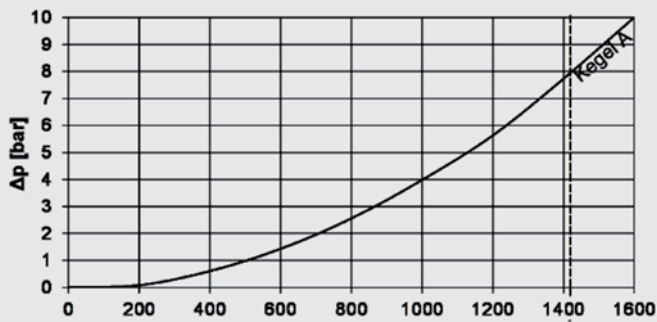

NG80

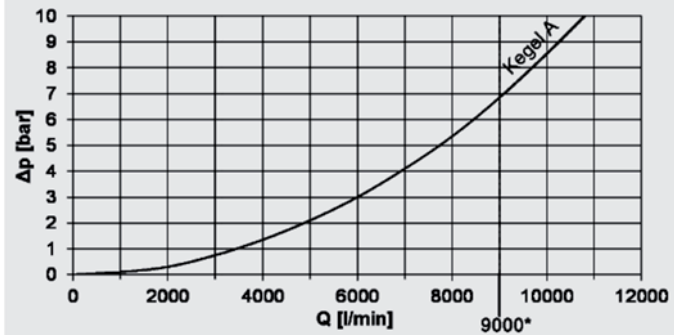

NG40

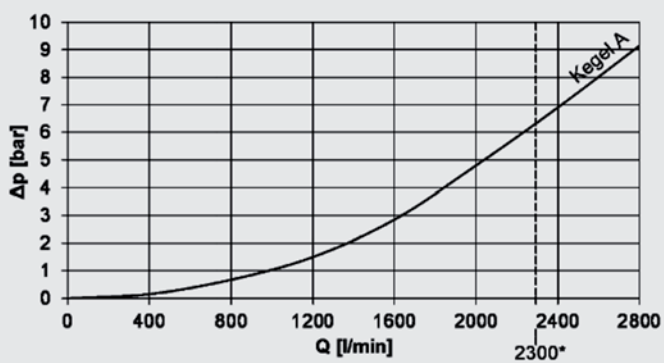

ACCESSORIES

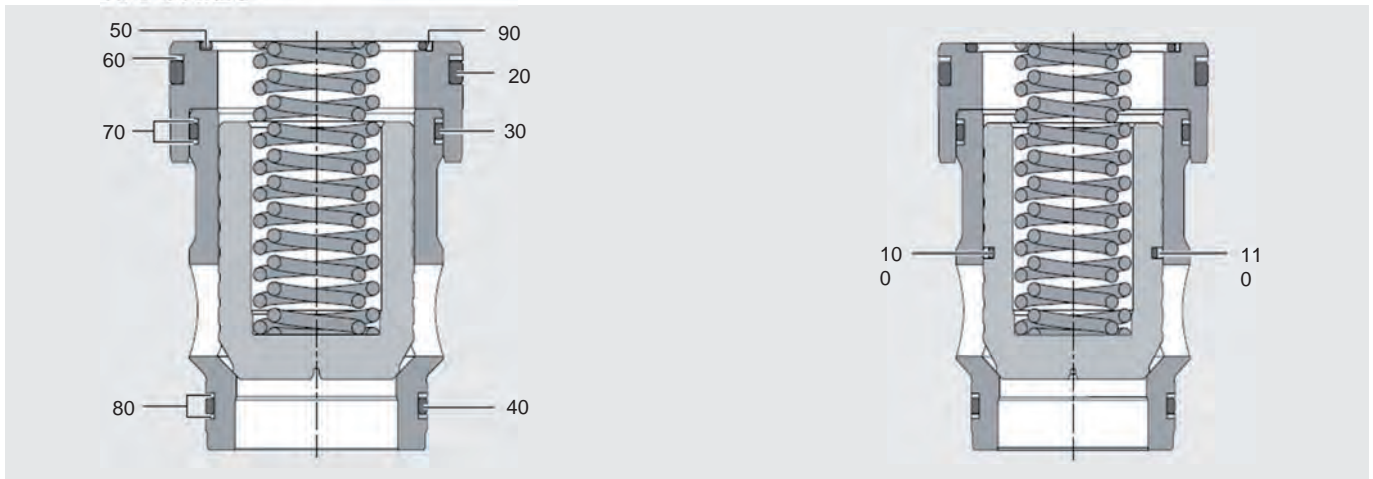

NG	Number	Code	Part no.	
			NBR	FKM
16	20, 30, 40, 50, 60, 70, 80	Seal kit L-CEE 16 H	4055840	4055843
	20, 30, 40, 50, 60, 70, 80, 100, 110	Seal kit L-CEE 16 H X	4055846	4055848
25	20, 30, 40, 50, 60, 70, 80	Seal kit L-CEE 25 H	4055851	4055867
	20, 30, 40, 50, 60, 70, 80, 100, 110	Seal kit L-CEE 25 H X	4055868	4055869
32	20, 30, 40, 50, 60, 70, 80	Seal kit L-CEE 32 H	4055870	4055872
	20, 30, 40, 50, 60, 70, 80, 100, 110	Seal kit L-CEE 32 H X	4055874	4055895
40	20, 30, 40, 50, 60, 70, 80	Seal kit L-CEE 40 H	4055896	4055898
	20, 30, 40, 50, 60, 70, 80, 100, 110	Seal kit L-CEE 40 H X	4055899	4055900
50	20, 30, 40, 50, 60, 70, 80, 90	Seal kit L-CEE 50 H	4055901	4055902
	20, 30, 40, 50, 60, 70, 80, 90, 100, 110	Seal kit L-CEE 50 H X	4055903	4055915
63	20, 30, 40, 50, 60, 70, 80, 90	Seal kit L-CEE 63 H	4055916	4055917
	20, 30, 40, 50, 60, 70, 80, 90, 100, 110	Seal kit L-CEE 63 H X	4055918	4055920
80	20, 30, 40, 50, 60, 70, 80, 90	Seal kit L-CEE 80 H	4486928	4486893
	20, 30, 40, 50, 60, 70, 80, 90, 100, 110	Seal kit L-CEE 80 H X	4486934	4486929

Removal tools

NG 16 to 50

The removal tool essentially consists of an expander with pins (3) and a striking weight (2).

For disassembly of the valve consider the following steps:

- A) Disassemble spring and poppet.
- B) Disassembly of the sleeve cap:

To first remove the sleeve cap, the removal tool must be inserted into the valve. The pins (3) on the expander must be inserted into the groove of the sleeve cap. Use the grip (1) to tension the expansion sleeve with the sleeve cap.

Subsequent, use the striking weight to pull the sleeve cap out of the control manifold.
- C) Obey the same steps in B to disassemble the valve sleeve. Insert the pins of the expander into the side holes of the valve sleeve to prevent damage to the valve's guide surfaces.

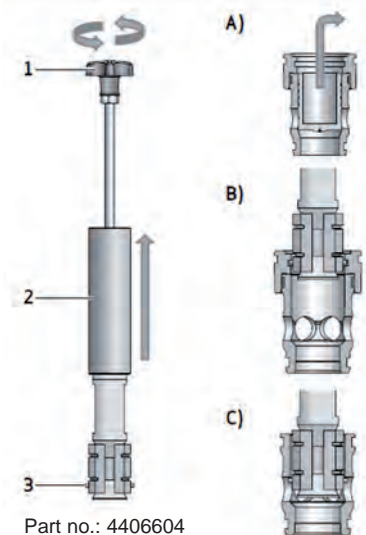

NG63 to 80

The removal tool consists of a spindle with bridge.

For disassembly of the valve consider the following steps:

- Screw the two threaded bolts of the bridge into the holes in the valve manifold, attach the bridge and lock it on both threaded bolts.
- Die zweite Spindel mit der Hülsenkappe verschrauben. Turn the spindle to pull the sleeve cap out of the hole in the valve manifold.
- Repeat step two to disassemble the valve sleeve.

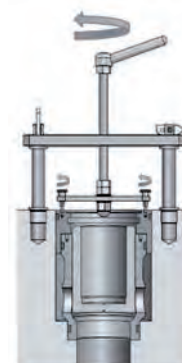

Note

The information in this brochure relates to the operating conditions and applications described. For applications not described, please contact the relevant technical department. Subject to technical modifications.

HYDAC Fluidtechnik GmbH
Justus-von-Liebig-Str.
D-66280 Sulzbach/Saar
Tel: 0 68 97 /509-01
Fax: 0 68 97 /509-598
E-Mail: valves@hydac.com

Control covers for 2-way cartridge valves series H LD-CCE

DESCRIPTION

HYDAC control valves are used for 2-way cartridge valves of the series H.

The optimised control cover design enables operating pressures up to 420 bar and ensures reliable function even in extreme conditions.

The control cover series includes a large selection of different functions. The integration of check and shuttle valves as well as the intersection to modular pilot control valves enables the buildup of a compact system.

The various control covers are available in sizes 16 to 63 and in some cases up to size 80.

FEATURES

- Control cover in combination with a 2-way cartridge valve for directional and check functions
- Designed for operating pressures up to 420 bar
- Large selection of functions for high flexibility in system design
- Interface according to ISO 7368:1989-08



CONTENT

Description
Features
Model code
Symbols
Technical Data
Range of orifice size
Installation options
General directional and pressure function
1D control cover
1H control cover
RM control cover
1W control cover
2W control cover
2WR control cover
4W control cover

MODEL CODE

LD-CCE 16 H 6 1H 2 / N / X15

Type

Control cover for 2-way cartridge valves

Nominal size (NG)

16, 25, 32, 40, 50, 63, 80 (depending on function, see chart „Symbols“)

Series

specified by manufacturer

Model

6 = mounting thread and control holes to ISO 7368

Symbols

1D, 1H, RM, 1W, 2W, 2WR, 4W (see chart „Symbols“)

Adjustment (1H cover only)

2 = hexagonal with lock nut (standard)

9 = hexagonal with lock nut and protective cap, sealable

Sealing material ¹

N = NBR (standard)

V = FKM

Orifice configuration ¹

/YXX : Y = port P, A, B, T, X, Y, Z1, Z2, C

XX = orifice diameter (e.g. 15 = 1,5 mm)

¹ other types on request

SYMBOLS

Type	Symbols	Preferred function	Oper. pressure [bar]	NG
1D		Control cover with remote control port for directional and check function.	420	16 to 80
1H		Control cover with remote control connection and stroke limitation for directional and check function as well as for manual switch-off and manual throttle functions.	420	16 to 63
RM		Control cover with interface for a directional valve. Can be used for directional functions.	420	16 to 80
1W		Control cover with interface for a directional valve. Additional control port for a second cartridge valve. Can be used for directional and pressure relief functions.	420	16 to 63
2W		Control cover with integrated shuttle valve for use as pilot-operated check valve, with interface for a directional valve.	420 (NBR) 350 (FKM)	16 to 63
2WR		Control cover with integrated shuttle valve for use as pilot-operated check valve, with interface for a directional valve.	420 (NBR) 350 (FKM)	16 to 63
4W		Control cover with interface for a directional valve. Additional check valves are integrated to realise functions for realisation of a maximum of two pilot control pressures.	420 (NBR) 350 (FKM)	16 to 80

TECHNICAL DATA

General specifications	
MTTFd	To DIN EN ISO 13849-1:2016 chart C1
Ambient temperature range	[°C] NBR: -30 to +80 FKM: -20 to +80
Installation position	No orientation restrictions
Material	Steel
Surface coating	Burnished
Hydraulic specifications	
Operating pressure	[bar] max. 420
Operating fluid	<ul style="list-style-type: none"> ▪ Hydraulic oil to DIN 51524 part 1, 2 and 3 ▪ NBR: HFB-/HFC- operating fluid ▪ FKM: HFD- operating fluid
Temp. range of operating fluid	[°C] NBR: -30 to +80 FKM: -20 to +80
Viscosity	[mm ² /s] 2,8 to 380
Permitted contamination level of operating fluid	class 20/18/15 to ISO 4406
Sealing material	NBR (standard), FKM

RANGE OF ORIFICE SIZE

The control covers LD-CCE of the H6 series are available with standard orifice. These types ensure the basic functionality of the combination with cover and cartridge valve and should be used if the application is not known or defined yet.

The final adjustment of the orifice diameter to optimise switching time and/or damping performance is the responsibility of the user or is only possible during application.

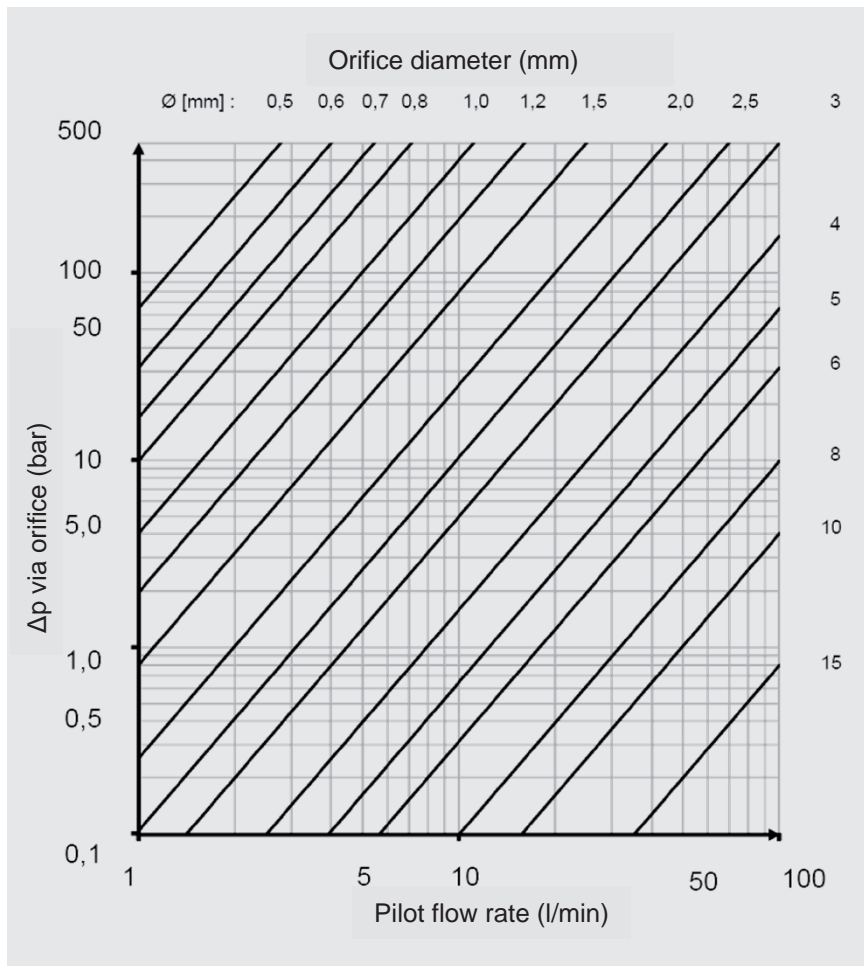

The size of the orifice influences the cartridge valve's opening and closing behaviour. If necessary, please use the following approximation for a different orifice diameter

$$t_{open/close} = \frac{V_{Control} \times 60}{Q}$$

$t_{open/close}$ [ms] = opening/closing time
 $V_{Control}$ [cm³] = pilot volume oil of logic valve
 Q [l/min] = flow via orifice (diagramm)

INSTALLATION OPTIONS OF THE ORIFICE IN THE CONTROL COVERS

Cover code	Orifice options									Orifices can be changed from the outside
	P	A	B	T	X	Y	Z1	Z2	C	
1D					X					All nominal sizes
1H					X					All nominal sizes
RM	X	X	X	X						-
1W	X	X	X	X				X	X	Z2 (for NG63 and NG80)
2W	X	X	X	X			X	X	X	Z1 und Z2 (for NG63 and NG80)
2WR	X	X	X	X	X				X	X (for NG63 and NG80)
4W	X	X	X	X				X	X	Z2 (for NG63 and NG80)

Ports	Nominal sizes						
	16	25	32	40	50	63	80
P, A, B, T	M6	M6	M6	M6	M6	M10	M10
X, C, Z1, Z2, Y	M5	M6	M6	M8	M8	M10	M14

Orifice 0,8	Part no.
Einbaudüse Steuerdeckel M5x0,8	6071916
Einbaudüse Steuerdeckel M6x0,8	6071917
Einbaudüse Steuerdeckel M8x0,8	6071918
Einbaudüse Steuerdeckel M10x0,8	6071919

Orifice 1,5	Part no.
Einbaudüse Steuerdeckel M5x1,5	6071920
Einbaudüse Steuerdeckel M6x1,5	6071921
Einbaudüse Steuerdeckel M6x1,5	6071922
Einbaudüse Steuerdeckel M10x1,5	6071923

General directional function

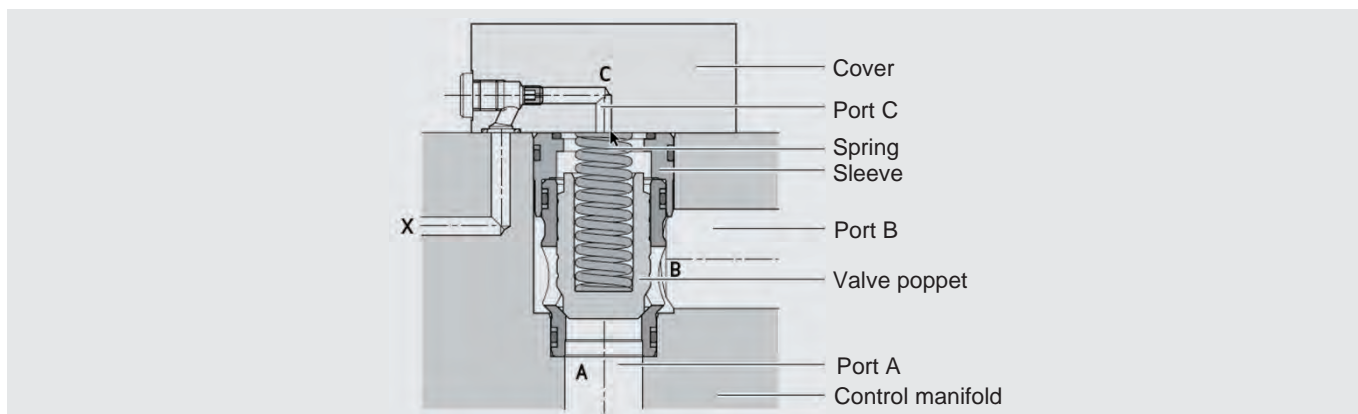

For a directional function, logic valves with poppet B, C, E or F are fundamentally suitable.

Furthermore, a cover is necessary to control the forces acting on the poppet.

The pressure acting on port A and B results to an opening force. The pressure in the spring chamber results to a closing force. The valve is closed due to the spring force if there is only a small pressure or no pressure.

You can see the 1D cover in the example. The pressure acts on the poppet via the port X causing the closing of the valve. If X is connected to the tank, only the spring force remains to close the valve.

General pressure function

Typical applications for a pressure relief function in cylinder and pumps.

For a pressure function, logic valves with poppet A and EX are fundamentally suitable. The special feature of these types is a minimal area ratio or no area ratio between port A and B. This leaves only two control areas (A and C).

The limited pressure is on port A, but is also channelled to port C of the cover at the same time. If the pressure in port A exceeds the value of the current pressure setting of pilot valve in port C, the valve opens.



Control cover function 1D NG 16 to 80

Symbol

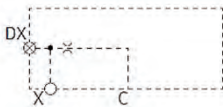

Directional function

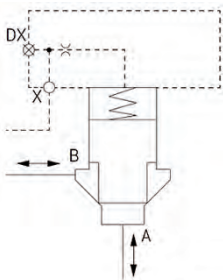

Check function

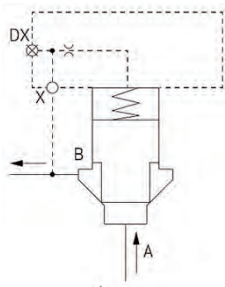

FUNCTION

- Control cover in combination with a 2-way cartridge valve for directional and check functions – depending on port X
- Control cover with remote control port to ISO 7368
- Orifice can be installed at port X
- The control cover 1D can be combined with 2-way cartridge valves with poppet B, C, E and F.

DIRECTIONAL VALVE FUNCTION

If a 1D cover is used in combination with a 2-way cartridge valve, the pressure at cover port X relieves to the tank by realising a 2-way function – flow direction from A → B or B → A.

The highest system pressure or the highest pressure from A or B on port X of the cover results a blocking of the flow from A to B – and conversely.

CHECK FUNCTION

If a 1D cover is used in combination with a 2-way cartridge valve, a check function can be realised by connecting control port X to port B - flow direction A → B (B → A blocked).

Standard models

The 1D cover is equipped with a single orifice in X, which can be accessed from the outside. This orifice is used to limit the flow from and to the C port of the cover and thus limit the opening and closing rate of the logic valve. For support with orifice configuration, please contact HYDAC Fluidtechnik GmbH.

NG	Without orifice		With standard orifice	
	Code	Part no.	Code	Part no.
16	LD-CCE 16 H 6 1D/N	4085071	LD-CCE 16 H 6 1D/N/X15	4091191
25	LD-CCE 25 H 6 1D/N	4085105	LD-CCE 25 H 6 1D/N/X15	4091206
32	LD-CCE 32 H 6 1D/N	4085106	LD-CCE 32 H 6 1D/N/X25	4091208
40	LD-CCE 40 H 6 1D/N	4085107	LD-CCE 40 H 6 1D/N/X30	4091212
50	LD-CCE 50 H 6 1D/N	4085108	LD-CCE 50 H 6 1D/N/X35	4091225
63	LD-CCE 63 H 6 1D/N	4085109	LD-CCE 63 H 6 1D/N/X35	4091227
80	LD-CCE 80 H 6 1D/N	4085139	LD-CCE 80 H 6 1D/N/X40	4091229

DIMENSIONS

NG 16 to 63

NG 80

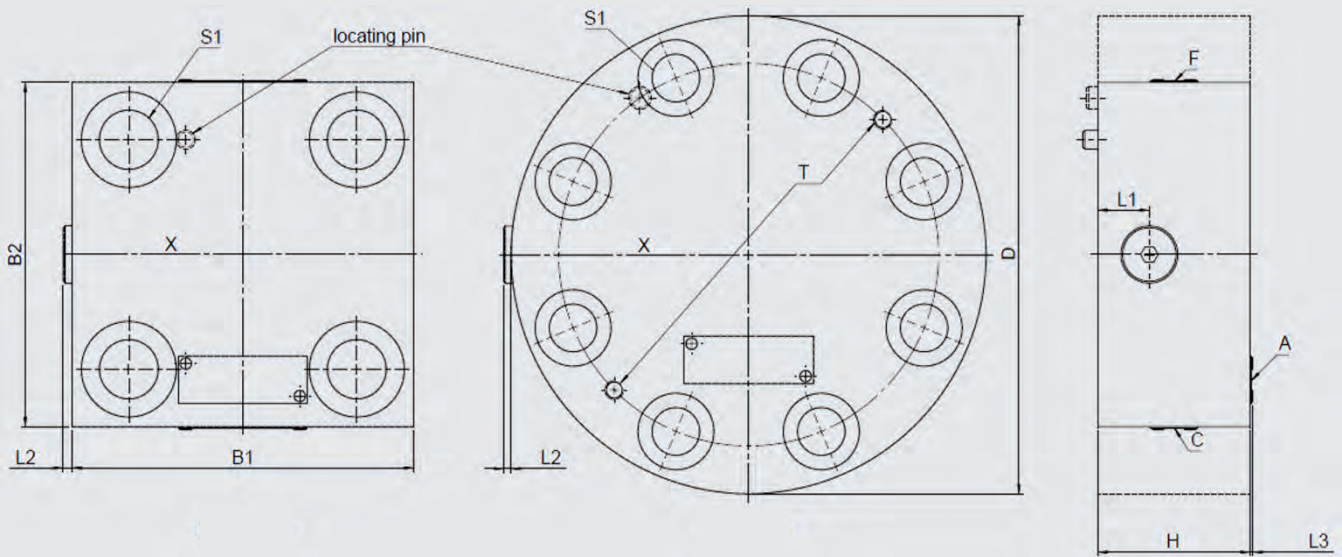

NG	16	25	32	40	50	63	80
B1 [mm (in)]	65 (2.56)	85 (3.35)	102 (4.02)	125 (4.92)	140 (5.51)	180 (7.09)	-
B2 [mm (in)]	65 (2.56)	85 (3.35)	102 (4.02)	125 (4.92)	140 (5.51)	180 (7.09)	-
D [mm (in)]	-	-	-	-	-	-	250 (9.84)
H [mm (in)]	35 (1.38)	35 (1.38)	45 (1.77)	60 (2.36)	60 (2.36)	80 (3.15)	80 (3.15)
L1 [mm (in)]	17 (0.67)	12 (0.47)	21 (0.83)	20 (0.79)	14 (0.55)	27 (1.06)	19 (0.75)
L2 [mm (in)]	3.5 (0.14)	3.5 (0.14)	4.5 (0.18)	4.5 (0.18)	4.5 (0.18)	4.5 (0.18)	4 (0.16)
L3 [mm (in)]	1.5 (0.06)	1.5 (0.06)	1.5 (0.06)	1.5 (0.06)	1.5 (0.06)	1.5 (0.06)	1.5 (0.06)
T (eye bolt thread)	-	-	-	-	-	-	M10
Name plate position	A	C	F	C	A	A	A
Plug DX	G 1/8 "	G 1/8"	G 1/4"	G 1/4"	G 1/4"	G 3/8"	G 1/2"
Torque [Nm (ft-lbs)]	12 (9)	12 (9)	27 (20)	27 (20)	27 (20)	56 (41)	72 (53)
Hex. size [mm]	5	5	6	6	6	8	10
Interface ISO 7368	BA-06-2-A	BB-08-2-A	BC-09-2-A	BD-10-2-A	BE-11-2-A	BF-12-2-A	BG-13-2-A
Mounting screws S1 *	M8x35	M12x40	M16x50	M20x70	M20x70	M30x90	M24x90
Torque [Nm (ft-lbs)]	30 (22)	100 (74)	300 (221)	550 (406)	550 (406)	1,800 (1,328)	900 (664)
Weight [kg (lb)]	1.1 (2.43)	1.7 (3.75)	3.1 (6.84)	6.3 (13.89)	8.2 (18.08)	17.0 (37.49)	27.0 (59.54)

* Not included in delivery



Control cover function 1H NG 16 to 80

Symbol

NG 18

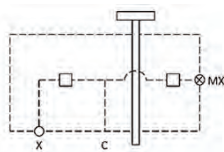

NG 25 to 63

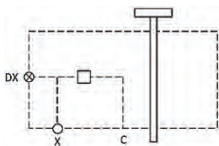

Directional and throttle function

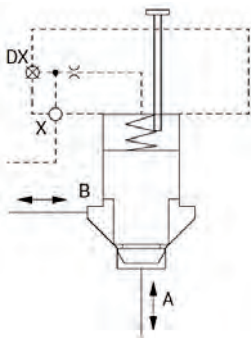

Check function

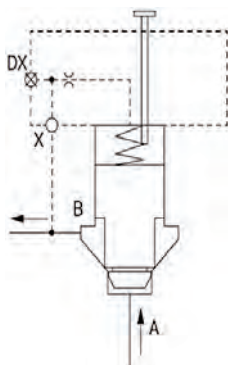

FUNCTION

- Control cover in combination with a 2-way cartridge valve for directional and check functions – depending on port X
- Control cover with remote control port to ISO 7368
- Orifice can be installed at port X
- Adjustable stroke limitation (throttle function)
- The control cover 1H can be combined with 2-way cartridge valves with poppet B, C, E and F.

DIRECTIONAL VALVE FUNCTION

If a 1H cover is used in combination with a 2-way cartridge valve, the pressure at cover port X relieves to the tank by realising a 2-way function – flow direction from A → B or B → A.

The highest system pressure or the highest pressure from A or B on port X of the cover results a blocking of the flow in both directions.

DROSSELFUNKTION

The adjustable stroke limitation throttles the flow in both directions.

Adjustment of the stroke limitation is only partially possible under pressure.

The stroke limitation could also cause the 2-way cartridge valve to close – but this is not the standard function.

CHECK FUNCTION

If port X of the 1H cover is connected to port B of the logic, a check function is realised. There is flow from A to B, but it is blocked in the opposite direction.

Hint

The 1H cover is incompatible with the following 2-way cartridge valves and must not be used with them: poppet A.

Other cartridge types, e.g. other cartridge series (D) or cartridge valves from other suppliers are not compatible with the 1H cover.

Standard models

The 1D cover is equipped with a single orifice in X, which can be accessed from the outside. This orifice is used to limit the flow from and to the C port of the cover and thus limit the opening and closing rate of the logic valve. For support with orifice configuration, please contact HYDAC Fluidtechnik GmbH.

NG	Without orifice		With standard orifice	
	Code	Part no.	Code	Part no.
16	LD-CCE 16 H 6 1H 2/N	4085218	LD-CCE 16 H 6 1H 2/N/X15	4091194
	LD-CCE 16 H 6 1H 9/N	4085219	LD-CCE 16 H 6 1H 9/N/X15	4091205
25	LD-CCE 25 H 6 1H 2/N	4085220	LD-CCE 25 H 6 1H 2/N/X15	4091207
			LD-CCE 25 H 6 1H 9/N/X15	4093430
32	LD-CCE 32 H 6 1H 2/N	4085221	LD-CCE 32 H 6 1H 2/N/X25	4091209
	LD-CCE 32 H 6 1H 9/N	4085223	LD-CCE 32 H 6 1H 9/N/X25	4091211
40	LD-CCE 40 H 6 1H 2/N	4085224	LD-CCE 40 H 6 1H 2/N/X30	4091214
50	LD-CCE 50 H 6 1H 2/N	4085265	LD-CCE 50 H 6 1H 2/N/X35	4091226
63	LD-CCE 63 H 6 1H 2/N	4085457	LD-CCE 63 H 6 1H 2/N/X35	4091228

CONTROL COVER - DETAILS

NG	16	25	32	40	50	63
Plug MX, DX	G 1/8 "	G 1/8"	G 1/4"	G 1/4"	G 1/4"	G 3/8"
Hex. size [mm]	5	5	6	6	6	8
Torque [Nm (ft-lbs)]	12 (9)	12 (9)	27 (20)	27 (20)	27 (20)	56 (41)
Stroke limiter SW1						
Schlüsselweite [mm]	8	8	8	13	13	17
Counter nut SW2						
Wrench size [mm]	19	19	19	27	27	46
Torque [Nm (ft-lbs)]	65 (48)	65 (48)	65 (48)	85 (63)	85 (63)	150 (111)
Cover screw SW3						
Wrench size [mm]	2,5	2,5	2,5	2,5	2,5	2,5
Torque [Nm (ft-lbs)]	5 (4)	5 (4)	5 (4)	5 (4)	5 (4)	5 (4)
Spindle guide SW4						
Schlüsselweite [mm]	36	36	36	36	36	65
Torque [Nm (ft-lbs)]	110 (81)	110 (81)	110 (81)	150 (111)	150 (111)	350 (258)
Mounting screws S1 *	M8 x 35	M12 x 40	M16 x 50	M20 x 70	M20 x 70	M30 x 90
Torque [Nm (ft-lbs)]	30 (22)	100 (74)	300 (221)	550 (406)	550 (406)	1,800 (1,328)
Weight [kg (lb)]	1.7 (3.75)	2.4 (5.29)	3.6 (7.94)	7.3 (16.1)	9.13 (20.13)	19.3 (42.56)

* Not included in delivery

DIMENSIONS

NG 16 to 63

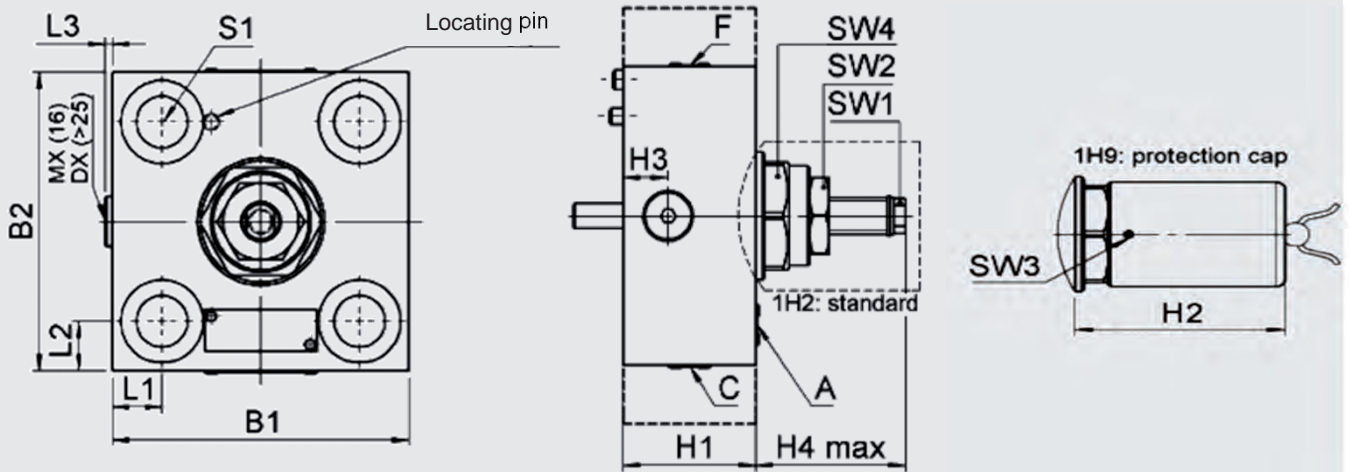

Hint for adjustment

1H covers ordered with adjustment 9 are supplied with a cover set for tamper protection. This set is delivered in a disassembled state with the cover and must be attached by the user.

The set consists of a protective cap, 1 pcs. mounting screw, 1 pcs. wire und 1 pcs. seal.

Covers ordered in standard adjustment 2 are delivered without protective cap.

NG	16	25	32	40	50	63
B1 [mm (in)]	65 (2.56)	85 (3.35)	102 (4.02)	125 (4.92)	140 (5.51)	180 (7.09)
B2 [mm (in)]	65 (2.56)	85 (3.35)	102 (4.02)	125 (4.92)	140 (5.51)	180 (7.09)
H1 [mm (in)]	35 (1.38)	35 (1.38)	45 (1.77)	60 (2.36)	60 (2.36)	80 (3.15)
H2 [mm (in)]	86.5 (3.41)	86.5 (3.41)	86.5 (3.41)	83.5 (3.29)	74 (2.91)	120 (4.72)
H3 [mm (in)]	9 (0.35)	9 (0.35)	21 (0.83)	20 (0.79)	14 (0.55)	27 (1.06)
H4 max [mm (in)]	56.5 (2.22)	56.5 (2.22)	62 (2.44)	71 (2.8)	64 (2.52)	90 (3.54)
L1 [mm (in)]	9.5 (0.37)	13.5 (0.53)	16 (0.63)	20 (0.79)	20 (0.79)	27.5 (1.08)
L2 [mm (in)]	9.5 (0.37)	13.5 (0.53)	16 (0.63)	20 (0.79)	20 (0.79)	27.5 (1.08)
L3 [mm (in)]	3.5 (0.14)	3.5 (0.14)	4.5 (0.18)	4.5 (0.18)	4.5 (0.18)	4.5 (0.18)
Name plate position	C	C	F	C	A	A
Interface ISO 7368	BA-06-2-A	BB-08-2-A	BC-09-2-A	BD-10-2-A	BE-11-2-A	BF-12-2-A



Control cover function RM NG 16 to 80

Symbol

NG 16 to 25

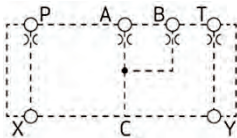

NG 32 to 50

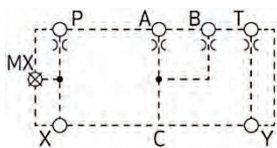

NG 63 to 80

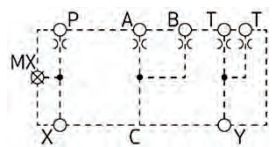

Directional function

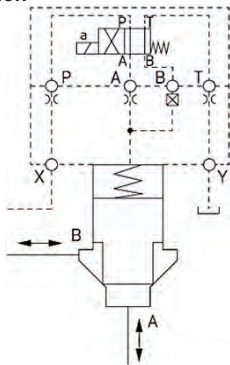

Pressure relief function

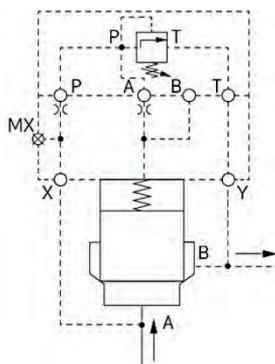

FUNCTION

- Control cover with remote control port to ISO 7368
- Orifice can be installed at port P, A, B, T
- Pilot port interface size 6 and 10 (size 6 pilot valves can be used up to control cover size 50, and size 10 pilot valves for control covers size 63 and above)
- Depending on the function, control cover RM can be combined with the following 2-way cartridge valves:
 - Pilot-operated directional function: 2-way cartridge valves with poppet B, C, E and F.
 - Pilot-operated pressure relief function: 2-way cartridge valve with valve poppet A or E.

DIRECTIONAL VALVE FUNCTION

If an RM cover is used in combination with a 2-way cartridge valve and a 4/2-way pilot valve, a 2-way function is realised when the solenoid is energized and a plug is in port B of the cover - with flow direction $A \rightarrow B$ or $B \rightarrow A$. This is achieved by pressure release of the spring chamber of 2-way cartridge valve. If the solenoid is not energized and a plug is in port B of the cover, the pilot pressure is applied to the spring chamber at port X. Depending on the pilot pressure, the corresponding flows are blocked. If the plug is installed in port A of the cover, the function for energized and de-energized solenoids is precisely the opposite.

PRESSURE RELIEF FUNCTION

If an RM cover is used with a 2-way cartridge valve and a pilot pressure relief valve, a pressure relief function can be realised.

Standard models

The orifice configurations possible with this cover are numerous and dependent on the pilot valve and the desired function. For further support with orifice configuration, please contact HYDAC Fluidtechnik GmbH.

NG	Code	Part no.
16	LD-CCE 16 H 6 RM/N	4085380
25	LD-CCE 25 H 6 RM/N	4085388
32	LD-CCE 32 H 6 RM/N	4085398
40	LD-CCE 40 H 6 RM/N	4085438
50	LD-CCE 50 H 6 RM/N	4085444
63	LD-CCE 63 H 6 RM/N	4085464
80	LD-CCE 80 H 6 RM/N	4085476

DIMENSIONS

NG 16 to 63

NG 80

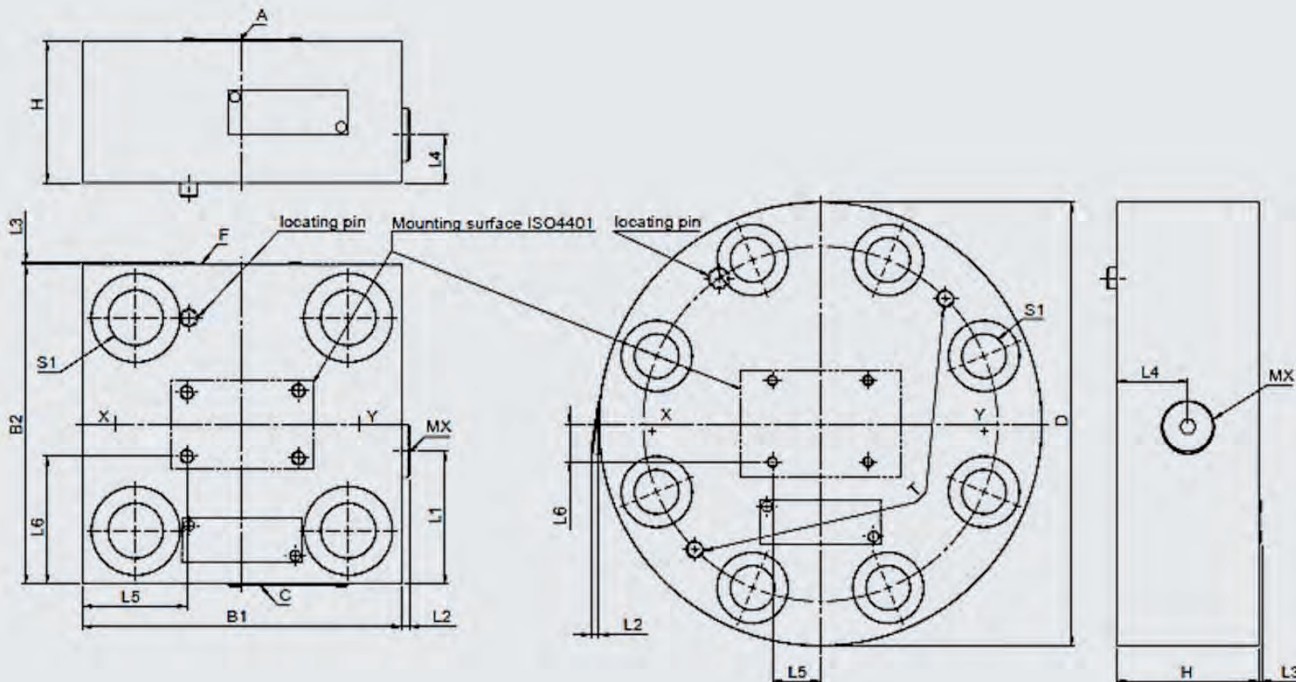

NG	16	25	32	40	50	63	80
B1 [mm (in)]	80 (3.15)	85 (3.35)	102 (4.02)	125 (4.92)	140 (5.51)	180 (7.09)	-
B2 [mm (in)]	65 (2.56)	85 (3.35)	102 (4.02)	125 (4.92)	140 (5.51)	180 (7.09)	-
D [mm (in)]	-	-	-	-	-	-	250 (9.84)
H [mm (in)]	35 (1.38)	40 (1.57)	45 (1.77)	60 (2.36)	60 (2.36)	80 (3.15)	80 (3.15)
L1 [mm (in)]	-	-	61.3 (2.41)	73 (2.87)	80.4 (3.17)	74.9 (2.95)	-
L2 [mm (in)]	-	-	3.5 (0.14)	4.5 (0.18)	4.5 (0.18)	4.5 (0.18)	2.5 (0.1)
L3 [mm (in)]	1.5 (0.06)	1.5 (0.06)	1.5 (0.06)	1.5 (0.06)	1.5 (0.06)	1.5 (0.06)	1.5 (0.06)
L4 [mm (in)]	-	-	27.0 (1.06)	30.0 (1.18)	30.0 (1.18)	57.0 (2.24)	40.0 (1.57)
L5 [mm (in)]	7.0 (0.28)	23.5 (0.93)	32.0 (1.26)	43.5 (1.71)	51.0 (2.01)	63.0 (2.48)	27.0 (1.06)
L6 [mm (in)]	16.25 (0.64)	26.25 (1.03)	34.65 (1.36)	46.25 (1.82)	53.75 (2.12)	68.6 (2.7)	21.4 (0.84)
T (eye bolt thread)	-	-	-	-	-	-	M10
Name plate position	C	C	F	C	A	A	A
Interface ISO 7368	BA-06-2-A	BB-08-2-A	BC-09-2-A	BD-10-2-A	BE-11-2-A	BF-12-2-A	BG-13-2-A

CONTROL COVER - DETAILS

NG	16	25	32	40	50	63	80
Pilot port Interface ISO 4401	03-02-0-05	03-02-0-05	03-02-0-05	03-02-0-05	03-02-0-05	05-04-0-05	05-04-0-05
Plug MX	-	-	G 1/8"	G 1/4"	G 1/4"	G 1/4"	G 3/8"
Hex. size [mm]	-	-	12 (9)	27 (20)	27 (20)	27 (20)	56 (41)
Torque [Nm (ft-lbs)]	-	-	5	6	6	6	8
Mounting screws S1 *	M8 x 35	M12 x 40	M16 x 50	M20 x 70	M20 x 70	M30 x 90	M24 x 90
Torque [Nm (ft-lbs)]	30 (22)	100 (74)	300 (221)	550 (406)	550 (406)	1,800 (1,328)	900 (664)
Wight [kg (lb)]	1.3 (2.87)	2.0 (4.41)	3.0 (6.62)	6.2 (13.67)	8.0 (17.64)	17.0 (37.49)	26.0 (57.33)

* Not included in delivery



Control cover function 1W NG 16 to 63

Symbol

NG 16 to 25

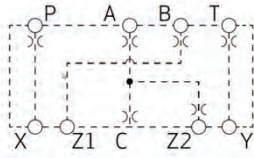

NG 32 to 50

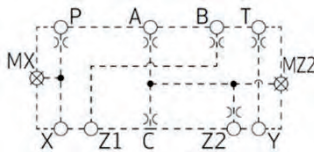

NG 63

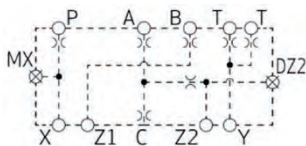

Directional function

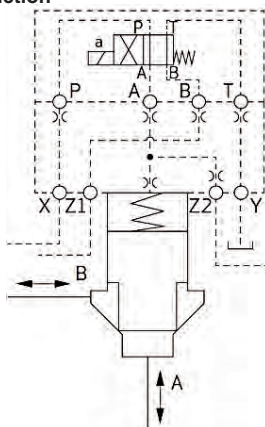

FUNCTION

- Control cover with remote control port to ISO 7368
- Orifice can be installed at port P, A, B, T
- Pilot port interface size 6 and 10 (size 6 4/2-way pilot valves can be used up to control cover size 50, and size 10 4/2-way pilot valves for control covers size 63 and above)
- The control cover 1W can be combined with 2-way cartridge valves with poppet B, C, E and F.

DIRECTIONAL VALVE FUNCTION

If a 1W cover is used in combination with a 2-way cartridge valve and a pilot valve, the same function is realised as RM cover.

If the solenoid of the directional valve is energized, the spring chamber of the cartridge valve is connected to the tank. This enables flow from port A to B, and conversely.

If the solenoid is de-energized, the spring chamber is supplied with pilot pressure from port X.

If this pilot pressure comes from port A of the cartridge valve, flow from A → B is blocked; if it comes from port B, it is blocked in the opposite direction. Furthermore, port Z1 and Z2 can be used to actuate another 2-way cartridge valve.

Standard models

The orifice configurations possible with this cover are numerous and dependent on the pilot valve used and the desired function.

For further support with orifice configuration, please contact HYDAC Fluidtechnik GmbH.

NG	Code	Part no.
16	LD-CCE 16 H 6 1W/N	4085375
25	LD-CCE 25 H 6 1W/N	4085381
32	LD-CCE 32 H 6 1W/N	4085391
40	LD-CCE 40 H 6 1W/N	4085399
50	LD-CCE 50 H 6 1W/N	4085440
63	LD-CCE 63 H 6 1W/N	4085458

DIMENSIONS

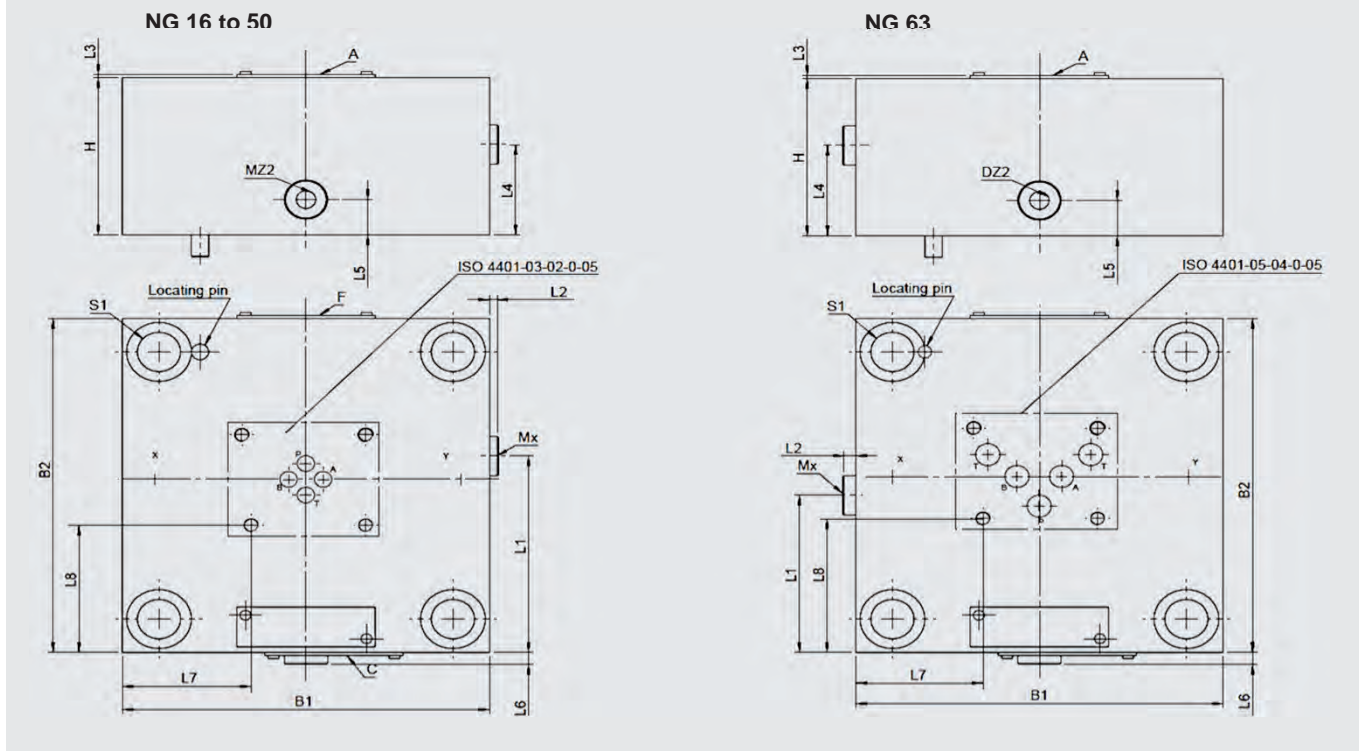

NG	16	25	32	40	50	63
B1 [mm (in)]	80 (3.15)	85 (3.35)	102 (4.02)	125 (4.92)	140 (5.51)	180 (7.09)
B2 [mm (in)]	65 (2.56)	85 (3.35)	102 (4.02)	125 (4.92)	140 (5.51)	180 (7.09)
H [mm (in)]	35 (1.38)	35 (1.38)	45 (1.77)	60 (2.36)	60 (2.36)	80 (3.15)
L1 [mm (in)]	-	-	61.3 (2.41)	80 (3.15)	80.4 (3.17)	74.9 (2.95)
L2 [mm (in)]	-	-	3.5 (0.14)	4.5 (0.18)	4.5 (0.18)	4.5 (0.18)
L3 [mm (in)]	1.5 (0.06)	1.5 (0.06)	1.5 (0.06)	1.5 (0.06)	1.5 (0.06)	1.5 (0.06)
L4 [mm (in)]	-	-	26 (1.02)	33.9 (1.33)	37.5 (1.48)	57 (2.24)
L5 [mm (in)]	-	-	15 (0.59)	20 (0.79)	21 (0.83)	26.25 (1.03)
L6 [mm (in)]	-	-	3.5 (0.14)	4.5 (0.18)	4.5 (0.18)	4.5 (0.18)
L7 [mm (in)]	7 (0.28)	23.5 (0.93)	32 (1.26)	43.5 (1.71)	51 (2.01)	63 (2.48)
L8 [mm (in)]	16.25 (0.64)	26.25 (1.03)	34.75 (1.37)	46.25 (1.82)	53.75 (2.12)	68.6 (2.7)
Name plate position	C	C	F	C	A	A
Interface ISO 7368	BA-06-2-A	BB-08-2-A	BC-09-2-A	BD-10-2-A	BE-11-2-A	BF-12-2-A

CONTROL COVER – DETAILS

NG	16	25	32	40	50	63
Pilot port Interface ISO 4401	03-02-0-05	03-02-0-05	03-02-0-05	03-02-0-05	03-02-0-05	05-04-0-05
Plug MP, MZ2 + DZ2	-	-	G 1/8"	G 1/4"	G 1/4"	G 1/4"
hex. size [mm]	-	-	5	6	6	6
Torque [Nm (ft-lbs)]	-	-	12 (9)	27 (20)	27 (20)	27 (20)
Mounting screws S1 *	M8 x 35	M12x40	M16x50	M20x70	M20x70	M30x90
Torque [Nm (ft-lbs)]	30 (22)	100 (74)	300 (221)	550 (406)	550 (406)	1,800 (1,328)
Weight [kg (lb)]	1.3 (2.87)	1.7 (3.75)	3.0 (6.62)	6.2 (13.67)	8.0 (17.64)	17.0 (37.49)

* Not included in delivery



Control cover function 2W NG 16 to 63

Symbol

NG 16 to 25

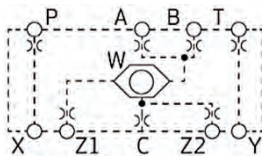

NG 32 to 50

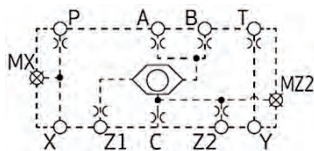

NG 63

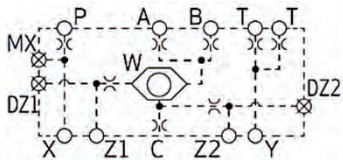

Pilot operated check function

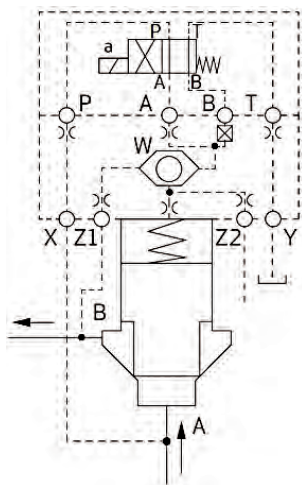

FUNCTION

- Control cover with integrated shuttle valve
- Control cover with remote control port to ISO 7368
- Orifice can be installed at port P, A, B, T, C, Z2
- Pilot port interface size 6 and 10 (size 6 4/2-way pilot valves can be used up to control cover size 50, and size 10 4/2-way pilot valves for control covers size 63 and above)
- The control cover 2W can be combined with 2-way cartridge valves with poppet B, C, E and F.

CHECK FUNCTION

2W cover with a 4/2-way pilot valve results in a pilot operated check function. As long as no port Z2 is not relieved - flow from port B → A is constantly blocked.

The flow direction A – B can be influenced by the switching position of the pilot directional valve. If there is a plug in B, flow A to B is open if the solenoid is energized; if the solenoid is de-energized, A to B is blocked.

If there is a plug in port A, the pilot function is conversely.

Depressurising Z2 opens flow from A to B on both sides.

Additionally, Z2 can be used to actuate other valves.

Standard models

The orifice configurations possible with this cover are numerous and dependent on the pilot valve used and the desired function.

For further support with orifice configuration, please contact HYDAC Fluidtechnik GmbH.

NG	Code	Part no.
16	LD-CCE 16 H 6 2W/N	4085377
25	LD-CCE 25 H 6 2W/N	4085384
32	LD-CCE 32 H 6 2W/N	4085394
40	LD-CCE 40 H 6 2W/N	4085403
50	LD-CCE 50 H 6 2W/N	4085441
63	LD-CCE 63 H 6 2W/N	4085460

DIMENSIONS

NG 16 to 50

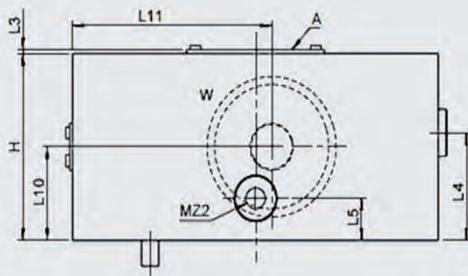

NG 63

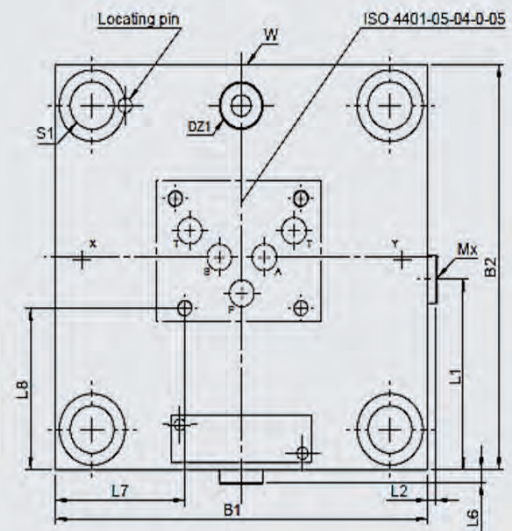
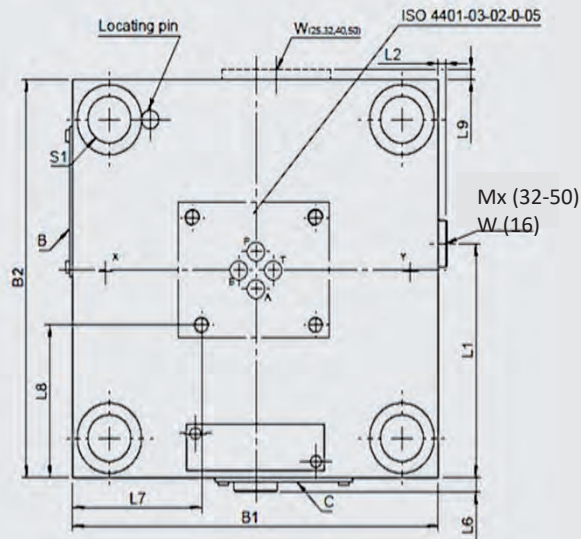
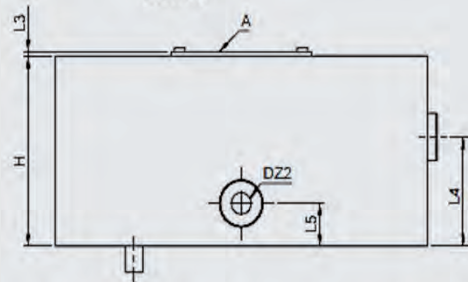

NG	16	25	32	40	50	63
B1 [mm (in)]	80 (3.15)	85 (3.35)	102 (4.02)	125 (4.92)	140 (5.51)	180 (7.09)
B2 [mm (in)]	65 (2.56)	85 (3.35)	102 (4.02)	125 (4.92)	140 (5.51)	180 (7.09)
H [mm (in)]	40 (1.57)	40 (1.57)	45 (1.77)	60 (2.36)	60 (2.36)	80 (3.15)
L1 [mm (in)]	35 (1.38)	-	58.9 (2.32)	73 (2.87)	80.4 (3.17)	74.5 (2.93)
L2 [mm (in)]	-	-	3.5 (0.14)	4.5 (0.18)	4.5 (0.18)	4.5 (0.18)
L3 [mm (in)]	1.5 (0.06)	1.5 (0.06)	1.5 (0.06)	1.5 (0.06)	1.5 (0.06)	1.5 (0.06)
L4 [mm (in)]	21 (0.83)	-	34 (1.34)	40.5 (1.59)	41 (1.61)	56 (2.2)
L5 [mm (in)]	-	-	21 (0.83)	17 (0.67)	18.5 (0.73)	26.25 (1.03)
L6 [mm (in)]	-	1.0 (0.04)	3.5 (0.14)	4.5 (0.18)	4.5 (0.18)	4.5 (0.18)
L7 [mm (in)]	7 (0.28)	23.5 (0.93)	32 (1.26)	43.5 (1.71)	51 (2.01)	63 (2.48)
L8 [mm (in)]	16.25 (0.64)	26.25 (1.03)	34.65 (1.36)	46.25 (1.82)	53.75 (2.12)	68.6 (2.7)
L9 [mm (in)]	1.6 (0.06)	2.5 (0.1)	-	-	-	-
L10 [mm (in)]	18 (0.71)	23 (0.91)	21 (0.83)	31 (1.22)	32 (1.26)	40 (1.57)
L11 [mm (in)]	46.2 (1.82)	45 (1.77)	51 (2.01)	62.5 (2.46)	70 (2.76)	79.7 (3.14)
Name plate position	C	C	B	C	A	A
Interface ISO 7368	BA-06-2-A	BB-08-2-A	BC-09-2-A	BD-10-2-A	BE-11-2-A	BF-12-2-A

CONTROL COVER - DETAILS

NG	16	25	32	40	50	63
Pilot port Interface ISO 4401	03-02-0-05	03-02-0-05	03-02-0-05	03-02-0-05	03-02-0-05	05-04-0-05
Plug Mx, MZ2, DZ1 + DZ2	-	-	G 1/8"	G 1/4"	G 1/4"	G 1/4"
Hex. size [mm]	-	-	5	6	6	6
Torque [Nm (ft-lbs)]	-	-	12 (9)	27 (20)	27 (20)	27 (20)
Plug W	G 3/8"	G 3/8"	G 3/8"	G 3/8"	G 3/8"	G 1/2"
Hex. size [mm]	8	8	8	8	8	10
Drehmoment [Nm (ft-lbs)]	56 (41)	56 (41)	56 (41)	56 (41)	56 (41)	72 (53)
Mounting screws S1 *	M8x35	M12x40	M16x50	M20x70	M20x70	M30x90
Torque [Nm (ft-lbs)]	30 (22)	100 (74)	300 (221)	550 (406)	550 (406)	1,800 (1,328)
Weight [kg (lb)]	1.5 (3.31)	2.0 (4.41)	3.0 (6.62)	6.2 (13.67)	8.0 (17.46)	16.5 (36.38)

* Not included in delivery



Control cover function 2WR NG 16 to 63

Symbol

NG 16 to 25

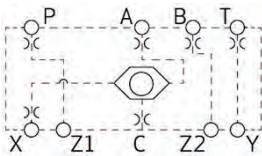

NG 32 to 50

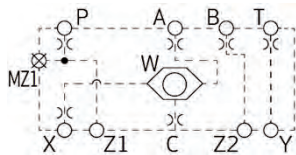

NG 63

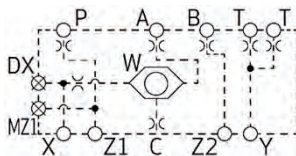

Pilot operated check function

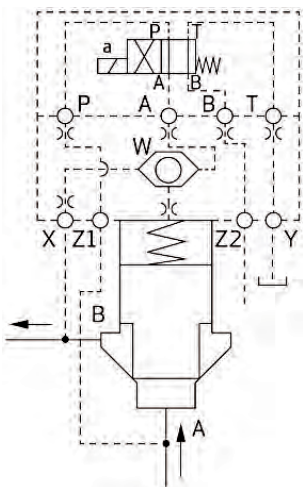

FUNCTION

- Control cover with integrated shuttle valve
→ maximum available pilot pressure is applied in the spring chamber (port C)
- Control cover with remote control port to ISO 7368
- Orifice can be installed at port P, A, B, T, X, C
- Pilot port interface size 6 and 10 (size 6 4/2-way pilot valves can be used up to control cover size 50, and size 10 4/2-way pilot valves for control covers size 63 and above)
- The control cover 2WR can be combined with 2-way cartridge valves with poppet B, C, E and F.

CHECK FUNCTION

If a 2WR cover is used in combination with a 2-way cartridge valve and a 4/2-way pilot valve, this results free flow from port A to B if the solenoid is energized.

If the pressure in port B exceeds the pressure in port A, the 2-way cartridge valve is closed and flow in direction B to A is blocked.

If the solenoid is de-energized, flow in both directions (A → B and B → A) is blocked.

Furthermore, port Z2 can be used to actuate other 2-way cartridge valves.

Standard models

The orifice configurations possible with this cover are numerous and dependent on the pilot valve used and the desired function.

For further support with orifice configuration, please contact HYDAC Fluidtechnik GmbH.

NG	Code	Part no.
16	LD-CCE 16 H 6 2WR/N	4085378
25	LD-CCE 25 H 6 2WR/N	4085385
32	LD-CCE 32 H 6 2WR/N	4085395
40	LD-CCE 40 H 6 2WR/N	4085435
50	LD-CCE 50 H 6 2WR/N	4087273
63	LD-CCE 63 H 6 2WR/N	4085461

DIMENISONS

NG 16 to 50

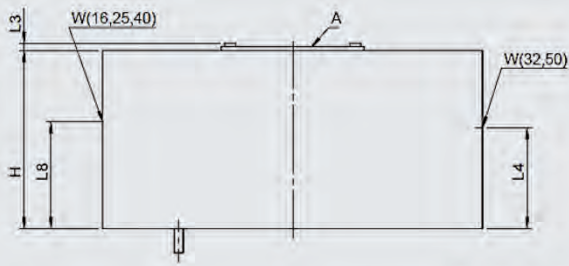

NG 63

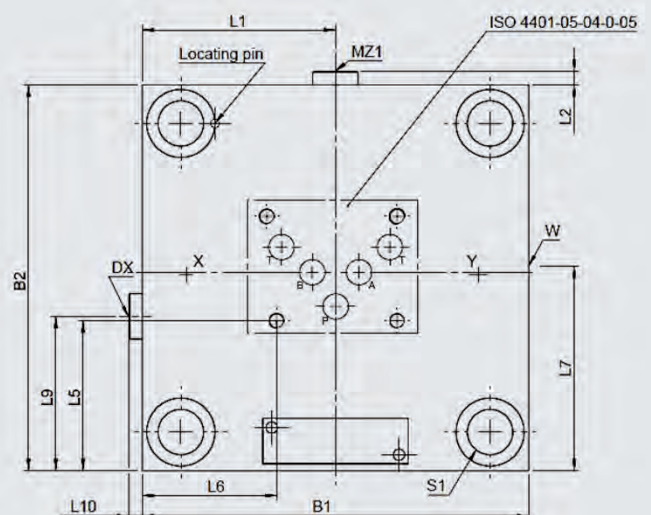
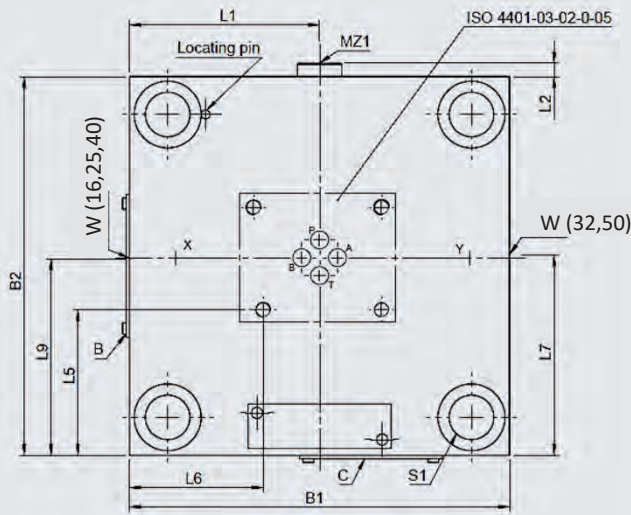
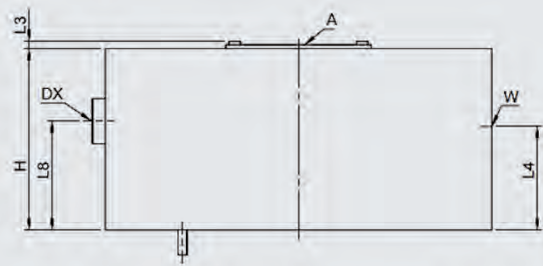

NG	16	25	32	40	50	63
B1 [mm (in)]	80 (3.15)	85 (3.35)	102 (4.02)	125 (4.92)	140 (5.51)	180 (7.09)
B2 [mm (in)]	65 (2.56)	85 (3.35)	102 (4.02)	125 (4.92)	140 (5.51)	180 (7.09)
H [mm (in)]	40 (1.57)	40 (1.57)	45 (1.77)	60 (2.36)	60 (2.36)	80 (3.15)
L1 [mm (in)]	-	-	51 (2.01)	62.5 (2.46)	70 (2.76)	90 (3.54)
L2 [mm (in)]	-	-	3.5 (0.14)	4.5 (0.18)	4.5 (0.18)	4.5 (0.18)
L3 [mm (in)]	1.5 (0.06)	1.5 (0.06)	1.5 (0.06)	1.5 (0.06)	1.5 (0.06)	1.5 (0.06)
L4 [mm (in)]	-	-	17.5 (0.69)	-	31 (1.22)	44 (1.73)
L5 [mm (in)]	16.25 (0.64)	26.25 (1.03)	34.65 (1.36)	46.25 (1.82)	73 (2.87)	68.6 (2.7)
L6 [mm (in)]	7 (0.28)	23.5 (0.93)	32 (1.26)	43.5 (1.71)	53.75 (2.12)	63 (2.48)
L7 [mm (in)]	-	-	63 (2.48)	-	51 (2.01)	70 (2.76)
L8 [mm (in)]	16.5 (0.65)	21 (0.83)	-	34.5 (1.36)	-	44 (1.73)
L9 [mm (in)]	31.5 (1.24)	43.5 (1.71)	-	64 (2.52)	-	70 (2.76)
L10 [mm (in)]	-	-	-	-	-	4.5 (0.18)
Name plate position	C	C	B	C	A	A
Interface ISO 7368	BA-06-2-A	BB-08-2-A	BC-09-2-A	BD-10-2-A	BE-11-2-A	BF-12-2-A

CONTROL COVER - DETAILS

NG	16	25	32	40	50	63
Pilot port Interface ISO 4401	03-02-0-05	03-02-0-05	03-02-0-05	03-02-0-05	03-02-0-05	05-04-0-05
Plug DX + MZ1	-	-	G 1/8"	G 1/4"	G 1/4"	G 1/4"
Hex. size [mm]	-	-	12 (9)	27 (20)	27 (20)	27 (20)
Torque [Nm (ft-lbs)]	-	-	5	6	6	6
Plug W	G 3/8"	G 3/8"	G 3/8"	G 3/8"	G 3/8"	G 3/4"
Hex. size [mm]	8	8	8	8	8	12
Torque [Nm (ft-lbs)]	56 (41)	56 (41)	56 (41)	56 (41)	56 (41)	120 (89)
Mounting screws S1 *	M8x35	M12x40	M16x50	M20x70	M20x70	M30x90
Torque [Nm (ft-lbs)]	30 (22)	100 (74)	300 (221)	550 (406)	550 (406)	1,800 (1,328)
Weight [kg (lb)]	1.5 (3.31)	2.0 (4.41)	3.0 (6.62)	6.2 (13.67)	9.0 (19.85)	23.6 (52.04)

* Not included in delivery



Control cover function 4W NG 16 to 80

Symbol

NG 16 to 25

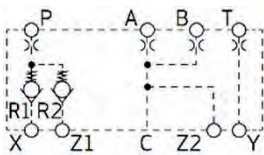

NG 32 to 50

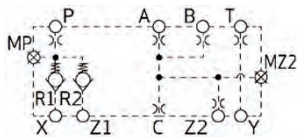

NG 63 to 80

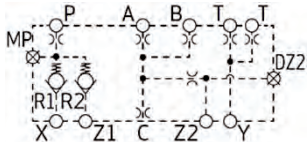

Directional function

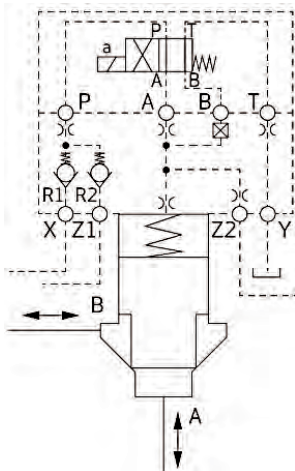

FUNCTION

- Control cover with parallel check valves at port X and Z1
 - The higher pressure of both is at port P
 - This feature is useful in applications where the risk of the 2-way cartridge valve briefly opening during the pilot pressure change needs to be fully eliminated.
- Control cover with remote control port to ISO 7368
- Orifice can be installed at port P, A, B, T, C, Z2
- Pilot port interface size 6 and 10 (size 6 4/2-way pilot valves can be used up to control cover size 50, and size 10 4/2-way pilot valves for control covers size 63 and above)
- The control cover 4W can be combined with 2-way cartridge valves with poppet B, C, E and F.

DIRECTIONAL VALVE FUNCTION

If a 4W cover is used in combination with a 2-way cartridge valve and a pilot valve, a bidirectional directional function or a check function can be realised. If the solenoid is energized and a plug is installed in port B of the cover, the spring chamber of the cartridge valve is connected to the tank. This enables flow via 2-way cartridge valve in both directions.

If the solenoid is de-energized, the higher of the two pilot pressures is at port X and Z1 in the spring chamber. This enables a check function - depending on location decrease of pilot pressure at port A or B in the corresponding direction:

- If the pilot pressure of port A is reduced, flow from A to B is blocked.
- If the pilot pressure of port B is reduced, flow from B to A is blocked.

Precisely the opposite functions are achieved in terms of a switching valve, which is on and off if a plug is installed in port A instead of port B. Furthermore, port Z2 can be used to actuate a second 2-way cartridge valve.

Standard models

The orifice configurations possible with this cover are numerous and dependent on the pilot valve used and the desired function. For further support with orifice configuration, please contact HYDAC Fluidtechnik GmbH.

NG	Code	Part no.
16	LD-CCE 16 H 6 4W/N	4085379
25	LD-CCE 25 H 6 4W/N	4085387
32	LD-CCE 32 H 6 4W/N	4085397
40	LD-CCE 40 H 6 4W/N	4085436
50	LD-CCE 50 H 6 4W/N	4085443
63	LD-CCE 63 H 6 4W/N	4085463
80	LD-CCE 80 H 6 4W/N	4085475

DIMENSIONS

NG 16 to 50

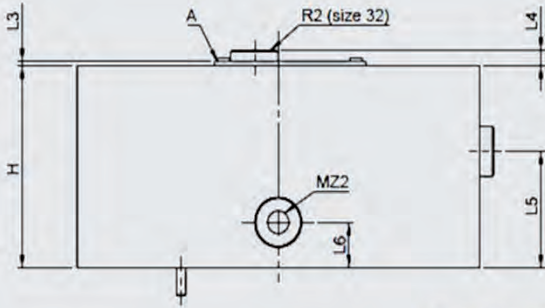

NG 63

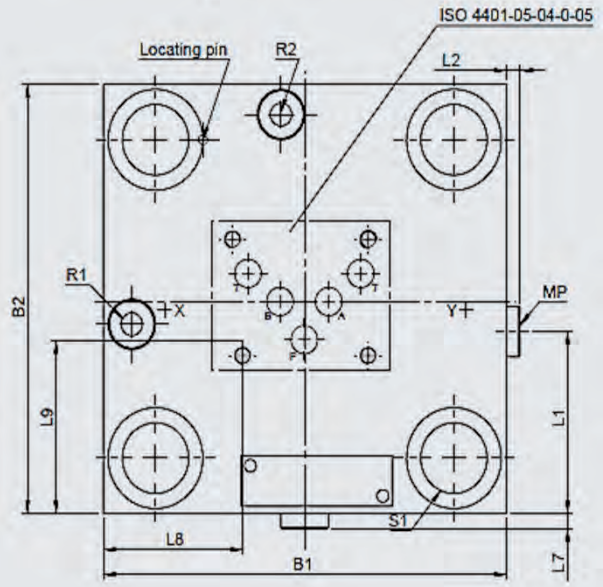
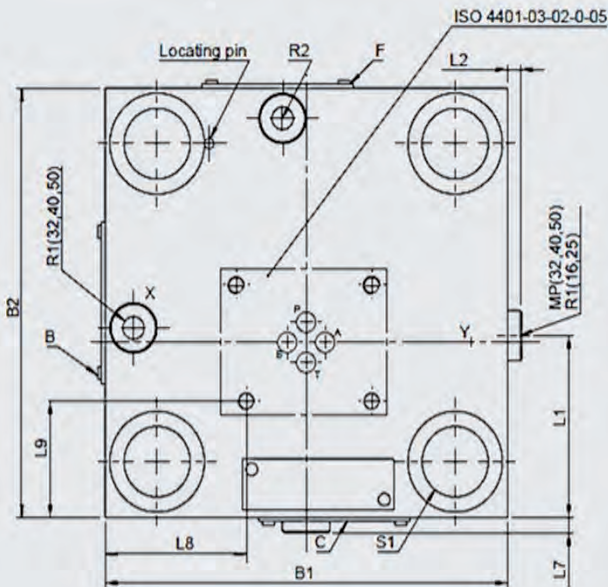
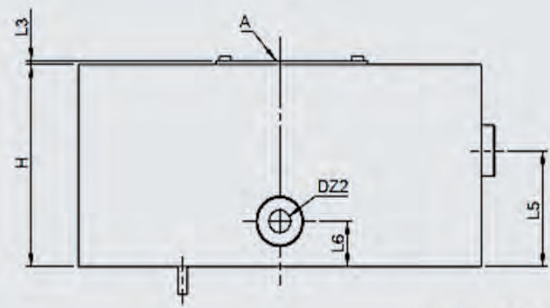

NG	16	25	32	40	50	63
B1 [mm (in)]	80 (3.15)	85 (3.35)	102 (4.02)	125 (4.92)	140 (5.51)	180 (7.09)
B2 [mm (in)]	65 (2.56)	85 (3.35)	102 (4.02)	125 (4.92)	140 (5.51)	180 (7.09)
H [mm (in)]	40 (1.57)	40 (1.57)	45 (1.77)	60 (2.36)	60 (2.36)	80 (3.15)
L1 [mm (in)]	43 (1.69)	53 (2.09)	59.5 (2.34)	73 (2.87)	82 (3.23)	74.5 (2.93)
L2 [mm (in)]	-	-	3.5 (0.14)	4.5 (0.18)	4.5 (0.18)	4.5 (0.18)
L3 [mm (in)]	1.5 (0.06)	1.5 (0.06)	1.5 (0.06)	1.5 (0.06)	1.5 (0.06)	1.5 (0.06)
L4 [mm (in)]	-	-	1 (0.04)	-	-	-
L5 [mm (in)]	17 (0.67)	20 (0.79)	24 (0.94)	38.5 (1.52)	39 (1.54)	45 (1.77)
L6 [mm (in)]	11.5 (0.45)	-	15 (0.94)	19 (0.75)	19 (0.75)	26.25 (1.03)
L7 [mm (in)]	1.4 (0.06)	-	3.5 (0.14)	4.5 (0.18)	4.5 (0.18)	4.5 (0.18)
L8 [mm (in)]	7 (0.28)	23.5 (0.93)	32 (1.26)	43.5 (1.71)	51 (2.01)	63 (2.48)
L9 [mm (in)]	16.25 (0.64)	26.25 (1.03)	34.65 (1.36)	46.25 (1.82)	53.75 (2.12)	68.6 (2.7)
Name plate position	C	C	F	C	A	A
Interface ISO 7368	BA-06-2-A	BB-08-2-A	BC-09-2-A	BD-10-2-A	BE-11-2-A	BF-12-2-A

DIMENSIONS

NG	80
D [mm (in)]	250 (9.84)
H [mm (in)]	80 (3.15)
L1 [mm (in)]	41.5 (1.63)
L2 [mm (in)]	2.5 (0.1)
L3 [mm (in)]	1.5 (0.06)
L4 [mm (in)]	18 (0.71)
L5 [mm (in)]	4 (0.16)
L6 [mm (in)]	27 (1.06)
L7 [mm (in)]	21.4 (1.06)
T (eye bolt thread)	M10
Interface ISO 7368	BG-13-2-A

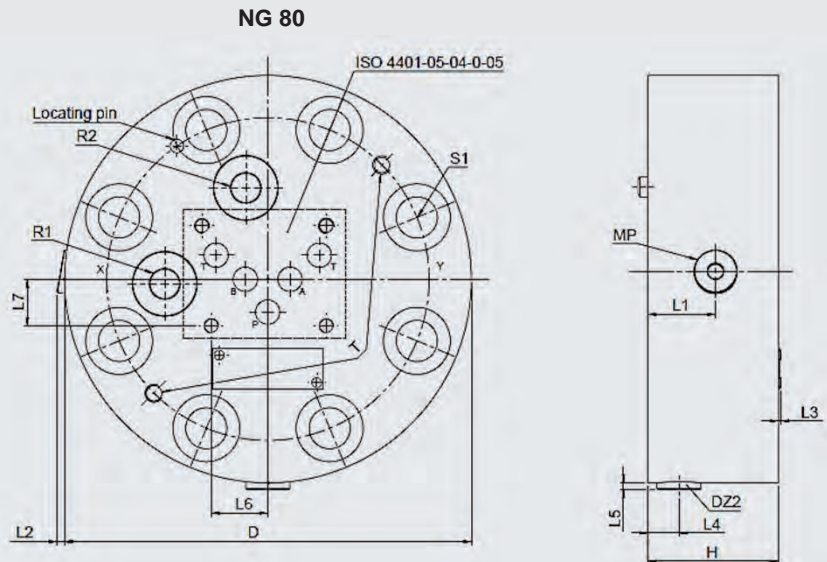

CONTROL COVER - DETAILS

NG	16	25	32	40	50	63	80
Pilot port Interface ISO 4401	03-02-0-05	03-02-0-05	03-02-0-05	03-02-0-05	03-02-0-05	05-04-0-05	05-04-0-05
Plug MP, MZ2, DZ2	-	-	G 1/8"	G 1/4"	G 1/4"	G 1/4"	G 3/8 "
Hex. size [mm]	-	-	12 (9)	27 (20)	27 (20)	27 (20)	56 (41)
Torque [Nm (ft-lbs)]	-	-	5	6	6	6	8
Plug R1 + R2	G 1/8"	G 1/8"	G 1/4"	G 3/8"	G 3/8"	G 1/2"	G 1"
Hex. size [mm]	12 (9)	12 (9)	27 (20)	56 (41)	56 (41)	80 (59)	170 (125)
Torque [Nm (ft-lbs)]	5	5	6	8	8	10	17
Mounting screws S1 *	M8x35	M12x40	M16x50	M20x70	M20x70	M30x90	M24x90
Torque [Nm (ft-lbs)]	30 (22)	100 (74)	300 (221)	550 (406)	550 (406)	1,800 (1,328)	900 (664)
Weight [kg (lb)]	1.5 (3.31)	2 (4.41)	3.0 (6.62)	6.2 (13.67)	9.0 (19.85)	16.5 (36.38)	26 (57.33)

ACCESSORIES

Seal kits (independent of cover function)	Code	Part no.
	LD-FS 16 H 6/N	4167630
	LD-FS 25 H 6/N	4167631
	LD-FS 32 H 6/N	4167632
	LD-FS 40 H 6/N	4167633
	LD-FS 50 H 6/N	4167634
	LD-FS 63 H 6/N	4167655
	LD-FS 80 H 6/N	4167657

Note

The information in this brochure relates to the operating conditions and applications described. For applications not described, please contact the relevant technical department.
All technical details are subject to change without notice.

HYDAC Fluidtechnik GmbH
Justus-von-Liebig-Str.
D-66280 Sulzbach/Saar
Tel: 0 68 97 /509-01
Fax: 0 68 97 /509-598
E-Mail: valves@hydac.com

Accessories for Industrial valves



CONTENT

4WE – Directional spool valves, solenoid-operated

WSE – Directional poppet valves, solenoid-operated

4WH – Directional spool valves, hydraulically pilot operated

ZW – Valves in sandwich plate design

VP – Plate mounted valves

P4WE – Proportional directional valves

L-CEE – 2-way cartridge valves

LD-CCE – Covers for 2-way cartridge valves

Model code plate types

Subplate

Cover plates

Crossover plates

4WE – Directional spool valves, solenoid-operated

	Nominal size	Designation	Part no.		
Seal kits (4-part set)	6	9,25 x 1,78 -80Sh -NBR	3492432		
		9,25 x 1,78 -80Sh -FKM	3120269		
	10	12,42 x 1,78 -80Sh -NBR	4348706		
		12,42 x 1,78 -80Sh -FKM	4348705		
Mounting screws (4 pcs)	6	M5 x 50 DIN EN ISO 4762 -10.9	4312231		
	10	M6 x 40 DIN EN ISO 4762 -10.9	3524314		
Solenoid coils	6	COIL 12DG -50-2345 -S	4244169		
		COIL 24DG -50-2345 -S	4244171		
		COIL 96DG -50-2345 -S	4244173		
		COIL 110DG -50-2345 -S	4330790		
		COIL 205DG -50-2345 -S	4244275		
		COIL 12DN -50-2345 -S	4244170		
		COIL 24DN -50-2345 -S	4244172		
		COIL 12DO -50-2345 -S	4250874		
		COIL 24DO -50-2345 -S	4250885		
		COIL 12DU -50-2345 -S	4250893		
		COIL 24DU -50-2345 -S	4250892		
		COIL 110AG -50-2345 -S	4244174		
		COIL 120AG -50-2345 -S	4348779		
		COIL 230AG -50-2345 -S	4244276		
	8 watts	COIL 24DG -50-2345;8W –S	4277864		
		COIL 24DO -50-2345;8W –S	4250889		
		COIL 24DN -50-2345;8W –S	4290983		
	10	COIL 12DG -75-3164 38W	4251228		
		COIL 24DG -75-3164 38W	4251230		
		COIL 96DG -75-3164 38W	4251232		
		COIL 110DG -75-3164 38W	4251233		
		COIL 125DG -75-3164 38W	4251234		
		COIL 205DG -75-3164 38W	4251255		
		COIL 220DG -75-3164 38W	4251257		
		COIL 12DN -75-3164 38W	4360072		
		COIL 24DN -75-3164 38W	4360073		
		COIL 24DO -75-3164 38W	4251262		
		Seal kit solenoid coils	6	Nut open, O-ring	4317299
				Nut with folding cap, O-ring	4317301
	Nut with cap, O-ring			4317302	
	10		Nut open, O-ring	4348711	
			Nut with folding cap, O-ring	4348713	
	Connector		6	Z4 standard, 2-pole without PE	394287
10		ZW4 incl. rectifier	394293		
		Z4L LED, 2-pole	394285		
Orifice	6	0,8 mm	6087869		
		1,5 mm	6087870		
	10	0,8 mm	6092411		
		1,5 mm	6092412		
Manual overrides	6	M4 with knurled-head screw	4429328		
		M5 with mushroom manual override (lockable)	4373722		
		M6 with mushroom manual override (not lockable)	4373490		

Hint

The chart lists accessory parts of the **A01** series.

Accessory parts for the **S01** series, please contact your technical contact person at HYDAC.

4WH – Directional spool valves, hydraulically operated

	Nominal size	Designation	Part no.
Seal kits	10 (7-part set)	12,42 x 1,78 -90 Sh -NBR (5 pcs)	3524475
		9,25 x 1,78 -90 Sh -NBR (2 pcs)	
		12,42 x 1,78 -90 Sh -FKM (5 pcs)	3524523
		9,25 x 1,78 -90 Sh -FKM (2 pcs)	
	16 (6-part set)	22,22 x 2,62 -90 Sh -NBR (4 pcs)	3524553
		10,82 x 1,78 -90 Sh -NBR (2 pcs)	
		22,22 x 2,62 -90 Sh -FKM (4 pcs)	3524634
		10,82 x 1,78 -90 Sh -FKM (2 pcs)	
	25 (6-part set)	29,82 x 2,62 -90Sh -NBR (4 pcs)	3524659
		20,24 x 2,62 -90Sh -NBR (2 pcs)	
		29,82 x 2,62 -90Sh -FKM (4 pcs)	3524660
		20,24 x 2,62 -90Sh -FKM (2 pcs)	
32 (6-part set)	37,59 x 3,53 -90Sh -NBR (4 pcs)	3524685	
	20,24 x 2,62 -90Sh -NBR (2 pcs)		
	37,59 x 3,53 -90Sh -FKM (4 pcs)	3524690	
	20,24 x 2,62 -90Sh -FKM (2 pcs)		
Mounting screws	10	M6x35 DIN EN ISO 4762 -10.9 (4 pcs)	3524691
	16	M10x60 (4 pcs)	3524695
		M6x50 (2 pcs)	
	25	M12x60 12.9 (6 pcs)	3524698
	32	M20x70 12.9 (6 pcs)	3524700
Plugs	10	M5x6 -45H	4452918
	16	M6x8 -45H	3524750
	25		
	32		

WSE – Directional poppet valves, solenoid-operated

	Nominal size	Designation	Part no.
Seal kits (4-part set)	6	9,25 x 1,78 -80Sh -FKM	3120269
Mounting screws (4 pcs)	6	M5 x 50 DIN EN ISO 4762 -10.9	4312231
Solenoid coils	6	COIL 24DG -50-2345 -S	4244171
		COIL 24DN -50-2345 -S	4244172
		COIL 24DO -50-2345 -S	4250885
		COIL 24DU -50-2345 -S	4250892
Seal kit solenoid coils	6	Nut open, O-ring	4317299
		Nut with cap, O-ring	4317302
Connector	6	Z4 standard, 2-pole without PE	394287
		Z4L incl. LED	394285
Orifice insert	6	Orifice for WSE 6 H01	4371106
Check valve	6	RV for WSE 6 H01	4371006

ZW – Valves in sandwich plate design

	Nominal size	Designation	Part no.
Seal kits	6 (4-part set)	9,25 x 1,78 -80 Sh -NBR	3492432
		9,25 x 1,78 -80 Sh -FKM	3120269
	10 (5-part set)	12,42 x 1,78 -80 Sh -NBR	3492434
		12,42 x 1,78 -80 Sh -FKM	3492433
	16 (6-part set)	22,22 x 2,62 -90 Sh -NBR (4 pcs)	3524553
		10,82 x 1,78 -90 Sh -NBR (2 pcs)	
		22,22 x 2,62 -90 Sh -FKM (4 pcs)	3524634
		10,82 x 1,78 -90 Sh -FKM (2 pcs)	
	25 (6-part set)	29,82 x 2,62 -90 Sh -NBR (4 pcs)	3524659
		20,24 x 2,62 -90 Sh -NBR (2 pcs)	
		29,82 x 2,62 -90 Sh -FKM (4 pcs)	3524660
		20,24 x 2,62 -90 Sh -FKM (2 pcs)	

VP – Plate mounted valves

	Valve type	Designation	Part no.
Seal kits	VP-P2SRR 6 VP-2SR 6 VP-P2SRE 6	14 x 2 -NBR (2 pcs) 14 x 2 -FKM (2 pcs)	3526072 3526085
	VP-RP6 VP-DRP 6 VP-PDB 6 VP-PDRP 6	9,25 x 1,78 -NBR (4 pcs) 9,25 x 1,78 FKM (4 pcs)	3526088 3526091
	VP-DBP 10 VP-PDBP 10	17,86 x 2,62 -NBR (2 pcs) 9,19 x 2,62 -NBR (1 pcs) 17,86 x 2,62 -FKM (2 pcs) 9,19 x 2,62 -FKM (1 pcs)	3526094 3526098
	VP-DRP 10 VP-RP 10	17,13 x 2,62 -NBR (2 pcs) 5,28 x 1,78 -NBR (2 pcs) 17,13 x 2,62 -FKM (2 pcs) 5,28 x 1,78 -FKM (2 pcs)	3526099 3526101
	VP-2SR 10	15 x 2,5 -NBR (2 pcs) 15 x 2,5 -FKM (2 pcs)	3526102 3526103
	VP-2SR 6	M5 x 75 (4 pcs)	3526118
	VP-RP 6 VP-DRP 6 VP-PDRP 6	M5x50 (4 pcs)	3526118
	VP-DBP 10 VP-PDBP 10	M12 x 40 (4 pcs)	3526122
	VP-DRP 10 VP-RP 10	M10 x 70 (4 pcs)	3526126
	VP-PDB 6	M5x30 (4 pcs)	3526129
	VP-P2SRE 6	M5x70 (4 pcs)	3526131
	VP-P2SRR 6	M5x65 (4 pcs)	3526133
	VP-2SR 10	M8x60 (4 pcs)	3526134
	Solenoid coils		On request
Connector		Z4 standard 2-pole without PE ZW4 incl. rectifier	394287 394293

P4WE – Proportional directional valves

	Nominal size	Designation	Part no.
Seal kits	6 (4-part set)	9,25 x 1,78 -90 Sh -FKM	3524413
		9,25 x 1,78 -90 Sh -NBR	3524355
	10 (4-part set)	12,45 x 1,78 90 Sh -FKM	3524439
		12,45 x 1,78 90 Sh -NBR	3524438
Mounting screws (4 pcs)	6 series A01	ISO 4762 M5x50	4312231
	6 series D01	ISO4762 M5x30	3524313
	10	ISO 4762 M6x40	3524314
Solenoid coils	6 series A01	COIL 12PG- 2.7 -50-2345 -S	4356846
		COIL 24PG- 5 -50-2345 -S	4356848
		COIL 12PN- 2.7 -50-2345 -S	4356849
		COIL 24PN- 5 -50-2345 -S	4356851
	6 series D01	Coil für P4WE / P4WEE 12Volt	3549725
		Coil für P4WE / P4WEE 24Volt	3549737
	10	Coil für P4WE / P4WEE 12Volt	3549738
		Coil für P4WE / P4WEE 24Volt	3549739
Seal kit solenoid coils	6 series A01	Nut open, O-ring	4317299
Connector	P4WE/ P4WER 6/ 10	Z4 standard, 2-pole ZW4 incl. rectifier	394287 394293
	Control module EHCD	P4WE/ P4WER 6/ 10	AM005XXXU
Main connector for OBE		6+PE EN175201 Part 804	6080324
Electronic for OBE		Lin-Bus Interface	3648934

L-CEE – 2-way cartridge valves

	Nominal size	Designation	Part no.
Seal kits	16	L-CEE 16 H -FKM	4055843
		L-CEE 16 H -NBR	4055840
		L-CEE 16 H X -FKM	4055848
		L-CEE 16 H X -NBR	4055846
	25	L-CEE 25 H -FKM	4055867
		L-CEE 25 H -NBR	4055851
		L-CEE 25 H X -FKM	4055869
		L-CEE 25 H X -NBR	4055868
	32	L-CEE 32 H -FKM	4055872
		L-CEE 32 H -NBR	4055870
		L-CEE 32 H X -FKM	4055895
		L-CEE 32 H X -NBR	4055874
	40	L-CEE 40 H -FKM	4055898
		L-CEE 40 H -NBR	4055896
		L-CEE 40 H X -FKM	4055900
		L-CEE 40 H X -NBR	4055899
	50	L-CEE 50 H -FKM	4055902
		L-CEE 50 H -NBR	4055901
		L-CEE 50 H X -FKM	4055915
		L-CEE 50 H X -NBR	4055903
	63	L-CEE 63 H -FKM	4055917
		L-CEE 63 H -NBR	4055916
		L-CEE 63 H X -FKM	4055920
		L-CEE 63 H X -NBR	4055918
	80	L-CEE 80 H -FKM	4486893
		L-CEE 80 H -NBR	4486928
		L-CEE 80 H X -FKM	4486929
		L-CEE 80 H X -NBR	4486934

Nominal size	Spring spare part depending on NG and poppet design with pressure specification [bar]					Part no. spring
	A	B	C	E	F	
16	0,5	0,5	0,5	0,3	0,3	4161593
	1,0	1,0	1,0	0,7	0,7	4161615
	2,0	1,9	1,9	1,4	1,4	4161616
	4,0	3,8	3,8	2,7	2,7	4161617
25	0,5	0,5	0,5	0,4	0,4	4161451
	1,0	1,0	1,0	0,7	0,7	4161452
	2,0	2,1	2,1	2,5	2,5	4161453
	4,0	4,2	4,2	3,0	3,0	4161454
32	0,5	0,5	0,5	0,4	0,4	4161624
	1,0	1,0	1,0	0,7	0,7	4161625
	2,0	2,0	2,0	1,4	1,4	4161626
	4,0	4,0	4,0	2,8	2,8	4161627
40	0,4	0,5	0,5	0,4	0,4	4161633
	0,7	1,0	1,0	0,7	0,7	4161634
	1,4	2,0	2,0	1,4	1,4	4161634 + 4161675
	2,9	4,0	4,0	2,9	2,9	4161676 + 4161675
50	0,4	0,5	0,5	0,4	0,4	4161585
	0,7	1,0	1,0	0,7	0,7	4161586
	1,4	2,0	2,0	1,4	1,4	4161587
	2,9	4,0	4,0	2,9	2,9	4161587 + 4161588
63	0,4	0,5	0,5	0,4	0,4	4161618
	0,7	1,0	1,0	0,7	0,7	4161619
	1,5	2,0	2,0	1,4	1,7	4161620
	2,9	4,0	4,0	2,9	2,9	4161620 + 4161623
80	0,4	0,5	0,5	0,4	0,4	4161629
	0,7	1,0	1,0	0,7	0,7	4161630
	1,4	2,0	2,0	1,4	1,4	4161631
	2,8	4,0	4,0	2,8	2,8	4161631 + 4161632

LD-CCE – Cover for 2-way cartridge valves

	Nominal size	Designation	Part no.
Seal kits	16	LD-FS 16 H 6/N	4167630
	25	LD-FS 25 H 6/N	4167631
	32	LD-FS 32 H 6/N	4167632
	40	LD-FS 40 H 6/N	4167633
	50	LD-FS 50 H 6/N	4167634
	63	LD-FS 63 H 6/N	4167655
	80	LD-FS 80 H 6/N	4167657
Mounting screws	16	M 8 x 35	3524859
	25	M 12 x 40	3526065
	32	M 16 x 50	3526067
	40	M 20 x 70	3526069
	50		
	63	M 30 x 90	3526070
	80	M 24 x 90	4514532
Orifice		M 5 x 0,8	6071916
		M 6 x 0,8	6071917
		M 8 x 0,8	6071918
		M 10 x 0,8	6071919
		M 5 x 1,5	6071920
		M 6 x 1,5	6071921
		M 6 x 1,5	6071922
		M 10 x 1,5	6071923

MODEL CODE PLATE TYPES

	AP - 6 - G3/8 - S01 / 1 / V
Type AP = Subplate UP = Crossover plate SP = Cover plate	AP
Nominal size (NG) 6, 10	6
Ports or function Not specified = cover plate G3/8 = NG6 G1/2 = NG10 PATB = connection PA/TB PBTA = connection PB/TA	G3/8
Series S01 = phosphate-plated S02 = zinc-plated	S01
Interface 1 = NG6: DIN 24340 form A6 ISO 4401 NG10: DIN 24340 form A10 ISO 4401	1
Sealing material V = FKM N = NBR	V

SUBPLATES

NG6

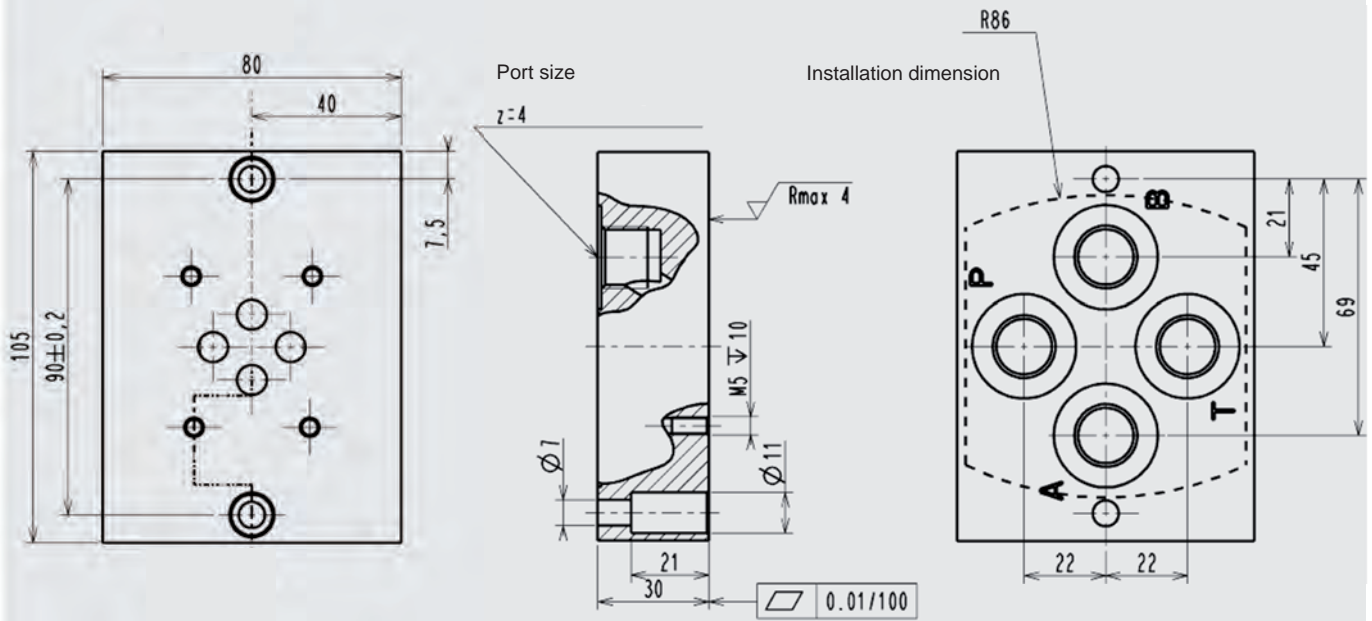

NG10

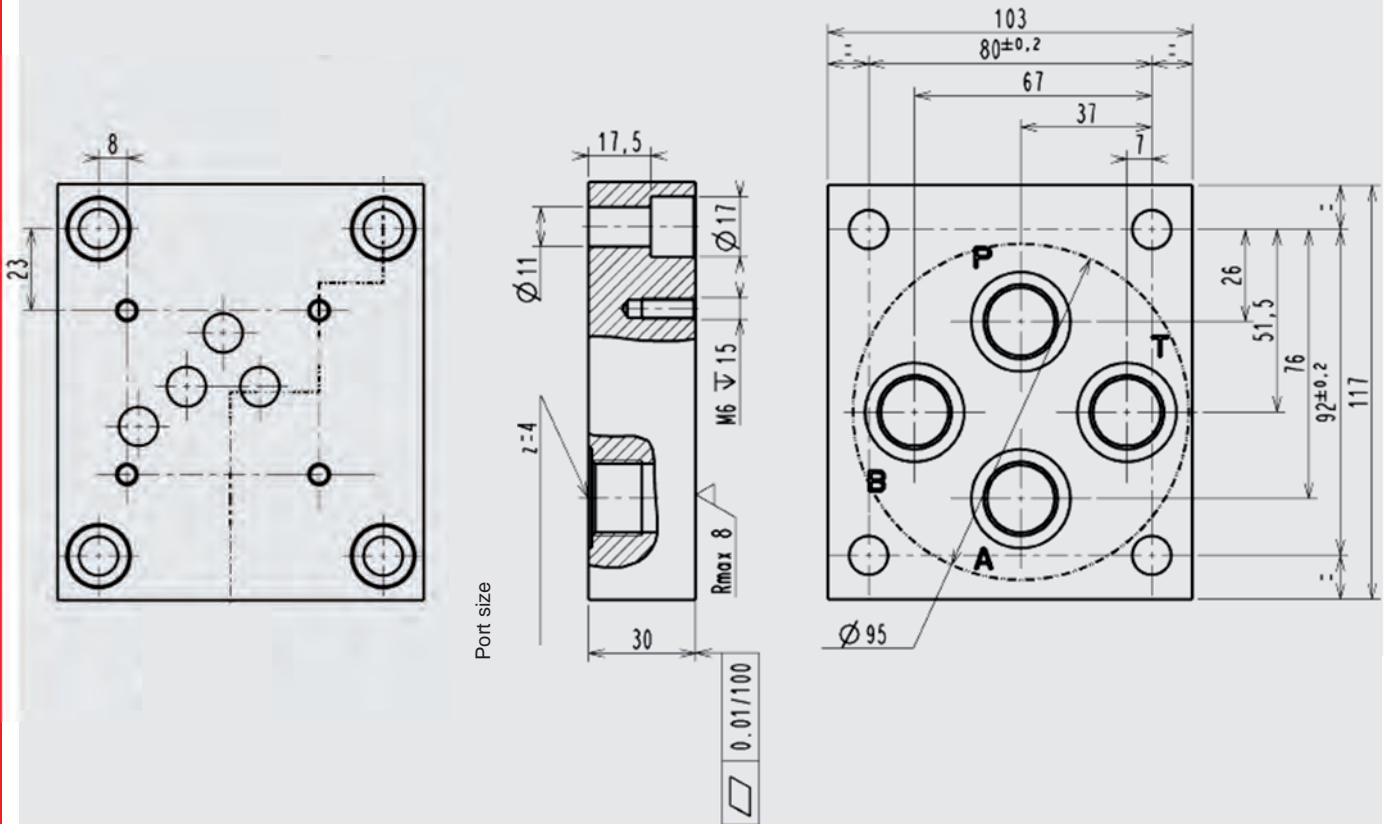

	Interface	Designation	Part no.
Subplate	ISO 4401-03-02-0-05	AP-6-G3/8-S01/1	3565254
	ISO 4401-05-04-0-05	AP-10-G1/2-S01/1	3565280

COVER PLATES

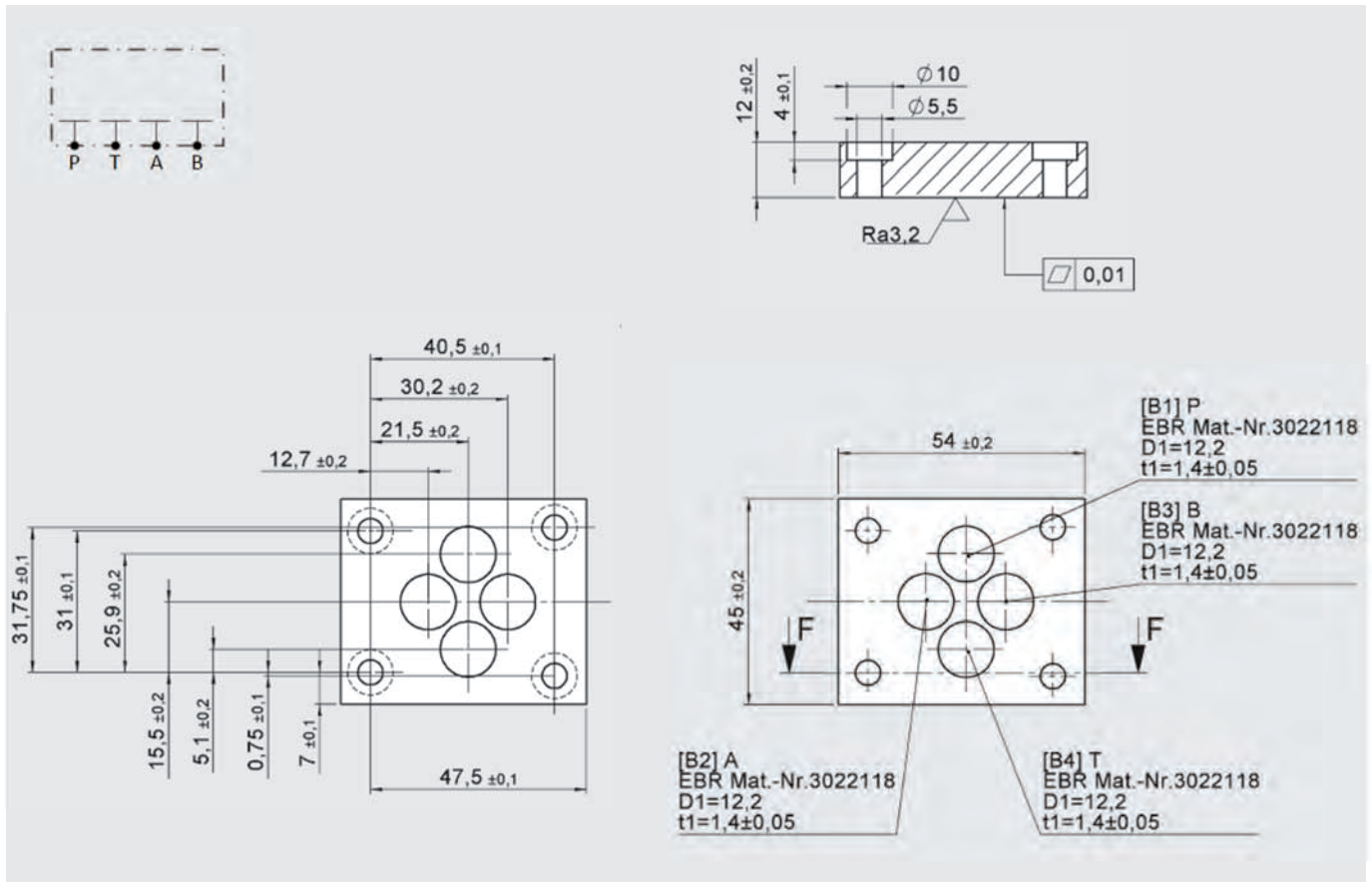

	Interface	Designation	Part no.
Cover plates	ISO 4401-03-02-0-05	SP-6-S01/1/N	3611576
		SP-6-S01/1/V	3611580
		SP-6-S02/1/N	3632323
		SP-6-S02/1/V	3632322
	ISO 4401-05-04-0-05	SP-10-S01/1/N	3738287
		SP-10-S01/1/V	3782210
		SP-10-S02/1/N	4136064
		SP-10-S02/1/V	4136105

CROSSOVER PLATES

PATB

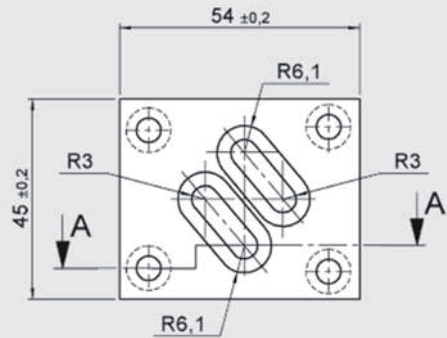
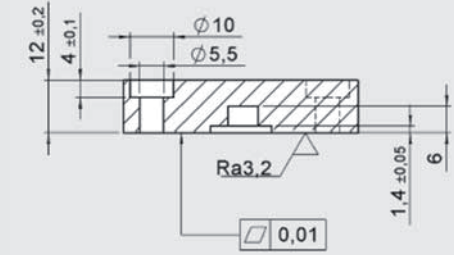
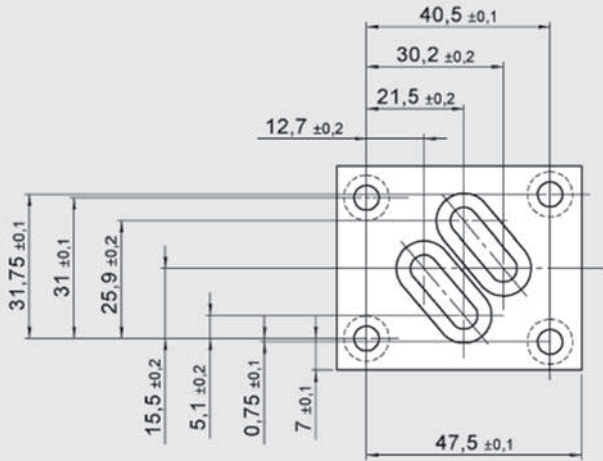

PBTA

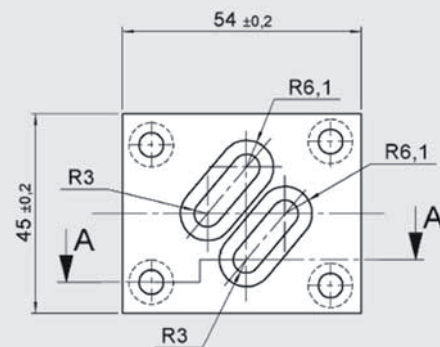
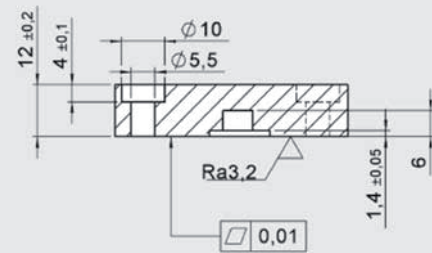
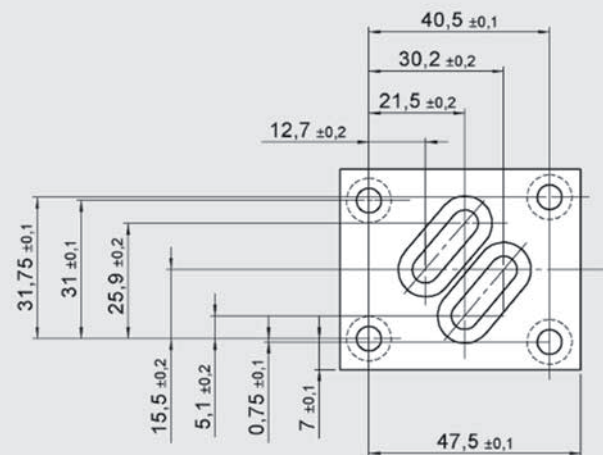

	Lochbild	Designation	Part no.
Crossover plates	ISO 4401-03-02-0-05	UP-6-PATB-S01/1/N	3581660
		UP-6-PATB-S01/1/V	3581661
		UP-6-PATB-S02/1/V	3648046
		UP-6-PBTA-S01/1/N	3581662
		UP-6-PBTA-S01/1/V	3581663

Note

The information in this brochure relates to the operating conditions and applications described. For applications not described, please contact the relevant technical department. All technical details are subject to change without notice.

HYDAC Fluidtechnik GmbH
Justus-von-Liebig-Str.
D-66280 Sulzbach/Saar
Tel: 0 68 97 /509-01
Fax: 0 68 97 /509-598
E-Mail: valves@hydac.com

DE	GERMANY HYDAC-Büro Südost Wiesestr. 189 07551 Gera Tel.: +49 (0)365 / 73 97 5320 Fax: +49 (0)365 / 73 97 5310 HYDAC-Büro Nordost Zum Kiesberg 16 14979 Großbeeren Tel.: +49 (0)33701 / 3389-0 Fax: +49 (0)33701 / 3389-4499 HYDAC-Büro Hamburg Mühlenweg 131-139 22844 Norderstedt Tel.: +49 (0)40 / 52 60 07-0 Fax: +49 (0)40 / 52 60 07-15 HYDAC-Büro Bremen Riedemannstr. 1 27572 Bremerhaven Tel.: +49 (0)471 / 700572-4200 Fax: +49 (0)471 / 700572-4242 HYDAC-Büro Nord Oldenburger Allee 41 30659 Hannover Tel.: +49 (0)511 / 56 35 35-0 Fax: +49 (0)511 / 56 35 35-56 HYDAC-Büro West Münchener Str. 61 45145 Essen Tel.: +49 (0)201 / 320 89 51-00 Fax: +49 (0)201 / 320 89 52-22 HYDAC-Büro Mitte Dieselstr. 9 64293 Darmstadt Tel.: +49 (0)6151 / 81 45-0 Fax: +49 (0)6151 / 81 45-22 HYDAC-Büro Südwest Rehgrabenstr. 3 66125 Saarbrücken-Dudweiler Tel.: +49 (0)6897 / 509-01 Fax: +49 (0)6897 / 509-1422 HYDAC-Büro Süd Dieselstr. 30 71546 Aspach Tel.: +49 (0)7191 / 34 51-0 Fax: +49 (0)7191 / 34 51-4033 HYDAC-Büro München Am Anger 8 82237 Würthsee/Etterschlag Tel.: +49 (0)8153 / 987 48-0 Fax: +49 (0)8153 / 987 48-4822 HYDAC-Büro Nürnberg Reichswaldstr. 52 90571 Schwab Tel.: +49 (0)9111 / 24 46 43-0 Fax: +49 (0)9111 / 24 46 43-260 HYDAC-Büro Berlin IBH Ingenieurbüro und Handelsvertretung Hammer GmbH Kaiser-Wilhelm-Str. 17 12247 Berlin Tel.: +49 (0)30 / 772 80 50 Fax: +49 (0)30 / 772 80 80	CH	SWITZERLAND HYDAC Engineering AG Allmendstr. 11 6312 Steinhausen/Zug Tel.: +41 41 / 747 03 21 Fax: +41 41 / 747 03 29 E-mail: hydac-engineering-AG@hydac.com Internet: www.hydac.ch HYDAC S.A. Zona Industriale 3, Via Sceresca 6805 Mezzovico Tel.: +41 91 / 935 57 00 Fax: +41 91 / 935 57 01 E-mail: info.coolingsystems@hydac.ch Internet: www.hydac.ch	IN	INDIA HYDAC INDIA PVT. LTD. A-58 TTC Industrial Area, MIDC, Mahape Navi Mumbai 400 701 Tel.: +91 22 / 411 18-888 Fax: +91 22 / 2778 11 80 E-mail: info@hydacindia.com	IT	ITALY HYDAC S.p.A. Via Archimede 76 20864 Agrate Brianza (MB) Tel.: +39 039 / 64 22 11 Fax: +39 039 / 68 99 682 E-mail: hydac@hydac.it Internet: www.hydac.it	JP	JAPAN HYDAC CO. LTD. Daiwa Hatchobori Ekimae Bldg. 2F 3-25-7 Hatchobori, Chuo-ku Teio 104-0032 Tel.: +81 3 / 35 37-3620 Fax: +81 3 / 35 37-3622 E-mail: sales@hydac.co.jp	KR	KOREA HYDAC Korea Co. Ltd. 6 th floor Daewon Bldg. 175 Bangbae Jungang-ro, Seocho-gu Seoul 137-829 Tel.: +82 2 / 591 09 31 Fax: +82 2 / 591 09 32 E-mail: info@hydacckorea.co.kr	LU	LUXEMBURG Friedrich-Hyrotech S.à.r.l. 16 Route d'Esch 3835 Schifflange Tel.: +352 54 52 44 Fax: +352 54 52 48	MX	MEXICO HYDAC International SA de CV Calle Alfredo A. Nobel No. 35 Colonia Puente de Vigas Tlalneantla Edo. De México, CP 54090 Tel.: +52 55 4777 1272 al 65 Fax: +52 55 5390 2334 Internet: www.hydacmex.com	MY	MALAYSIA HYDAC Technology Snd. Bhd. Lot 830, Kawasan Perindustrian Kampung Jaya, Jalan Kusta, 47000 Sungai Buloh Selangor Darul Ehsan Tel.: +60 3 / 6157 0250 Fax: +60 3 / 6157 0252	NL	NETHERLANDS HYDAC B.V. Vossenbeemd 109 5705 CL Helmond Tel.: +31 (0)88 0597 001 Fax: +31 (0)88 0597 020 E-mail: info@hydac.nl	NO	NORWAY HYDAC AS Borghagan 4 1405 Langhus Tel.: +47 64 85 86 00 Fax: +47 64 85 86 01 E-mail: firmapost@hydac.no	NZ	NEW ZEALAND HYDAC LTD. 108A Penrose Road Mount Wellington 1060 Auckland Tel.: +64 9271 4120 Fax: +64 9271 4124 E-mail: info@hydac.co.nz Internet: www.hydac.co.nz	PL	POLAND (Latvia, Lithuania) HYDAC SP.Z O.O. ul. Reymonta 17 43-190 Mikolow Tel.: +48 32 / 226 26 55, 326 01 10 Fax: +48 32 / 226 40 42 E-mail: info@hydac.com.pl Internet: www.hydac.com.pl	PT	PORTUGAL HYDAC TECNOLOGIA, UNIPESSOAL, LDA. Centro Empresarial do Castelo da Maia Rua Manuel Assunção falcão, 501 4475-041 Maia Tel.: +351 223 160 364 Fax: +351 223 160 265 E-mail: info@hydac.pt Internet: www.hydac.com	RO	ROMANIA HYDAC SRL 12 Soseaua Vestului Street, Et 2 100298, Ploiesti, Prahova county Prahova county Tel.: +40 244 575 778 Fax: +40 244 575 779 E-mail: hydac@hydac.ro Internet: www.hydac.ro	RU	RUSSIA HYDAC International ul. 4, Magistralnaya 5, office 31 123007 Moscow Tel.: +7 495 / 980 80 01 Fax: +7 495 / 980 70 20 E-mail: info@hydac.com.ru Internet: www.hydac.com.ru	RU	Technical Office St. Petersburg Nab. Obwodnogo kanala 138 190020 St. Petersburg Tel.: +7 812 / 495 9462 Fax: +7 812 / 495 9463 E-mail: petersb@hydac.com.ru Technical Office Novokuznetsk ul. Newskogo 1, office 300 654079 Novokuznetsk Tel.: +7 3843 99 1346 Fax: +7 3843 99 1345 E-mail: novokuz@hydac.com.ru Technical Office Ulyanovsk ul. Efreмова 29, office 418 432042 Ulyanovsk Tel.: +7 8422 61 3453 Fax: +7 8422 61 3452 E-mail: uljan@hydac.com.ru	SE	SWEDEN HYDAC Fluidteknik AB Domnarvsgatan 29 16353 Spångå Tel.: +46 8 / 445 29 70 Fax: +46 8 / 445 29 90 E-mail: hydac@hydac.se Internet: www.hydac.se	SG	SINGAPORE HYDAC Technology Pte Ltd. 7 Tuas Avenue 8 Singapore 639222 Tel.: +65 67 41 74 58 Fax: +65 67 41 04 34 E-mail: sales@hydac.com.sg Internet: www.hydac.com.sg	SI	SLOVENIA HYDAC d.o.o. Tržaška Cesta 39 2000 Maribor Tel.: +386 2 / 460 15 20 Fax: +386 2 / 460 15 22 E-mail: info@hydac.si Internet: www.hydac.si	SK	SLOVAKIA HYDAC S.R.O. Gorkého 4 036 01 Martin Tel.: +421 43 / 413 58 93, 423 73 94, 422 08 75 Fax: +421 43 / 422 08 74 E-mail: hydac@hydac.sk Internet: www.hydac.sk	TH	THAILAND AEROFUID CO. LTD. 169/4, 169/5, Moo 1 Rangsit-Nakhonnayok Rd. Patumthani 12110 Tel.: +66 2 / 577 2999 Fax: +66 2 / 577 2700 E-mail: info@aerofuid.com	TR	TURKEY HYDAC AKIŞKAN KONTROL SİSTEMLERİ SAN. VE TİC. LTD. ŞTİ. Namik Kemal Mahallesi Adile Naşit Bulvarı, 174 Sok. No. 9 34513 Esenyurt - İstanbul Tel.: +90 212 / 428 25 25 Fax: +90 212 / 428 70 37 E-mail: info@hydac.com.tr Internet: www.hydac.com.tr	TW	TAIWAN HYDAC Technology Ltd. No. 18, Shude 1 st Lane, South District Taichung City 40242 Tel.: +886 4 / 2260 2278 Fax: +886 4 / 2260 2352 E-mail: sales@hydac.com.tw Internet: www.hydac.com.tw	UA	UKRAINE HYDAC Kiev ul. Novokonstantinovskaya 9 Korpus 13, 2 Etage 04080 Kiev Tel.: +38 044 / 495 33 96, 495 33 97 Fax: +38 044 / 495 33 98 E-mail: info@hydac.com.ua Internet: www.hydac.com.ua	US	USA HYDAC Technology Corporation HYDAC Corp. 2260 & 2280 City Line Road Bethlehem, PA 18017 Tel.: +1 610 / 266 01 00 Fax: +1 610 / 266 35 40 E-mail: sales@hydacusa.com Internet: www.hydacusa.com	VN	VIETNAM HYDAC International E-Town Building, Mezzanine Floor Executive office, Room 7 364 Cong Hoa Street, Tan Binh District Ho Chi Minh City Tel.: +84 88 120 545 Ext. 215 Fax: +84 88 120 546	ZA	SOUTH AFRICA (Namibia, Zimbabwe) HYDAC Technology Pty Ltd. 165 Van der Bijl Street Edenvale 1614, Johannesburg Tel.: +27 11 / 723 90 80 Fax: +27 11 / 453 72 37 E-mail: hydacza@hydac.com
-----------	---	-----------	--	-----------	---	-----------	--	-----------	--	-----------	--	-----------	--	-----------	--	-----------	---	-----------	---	-----------	--	-----------	---	-----------	--	-----------	---	-----------	---	-----------	---	-----------	--	-----------	---	-----------	--	-----------	--	-----------	--	-----------	---	-----------	---	-----------	---	-----------	---	-----------	--	-----------	--	-----------	--



Accumulator Technology 30.000



Filter Technology 70.000



Process Technology 77.000



Filter Systems 79.000



Compact Hydraulics 63.000



Accessories 61.000



Electronics 180.000



Cooling Systems 57.000

Global Presence.
Local Expertise.
www.hydac.com

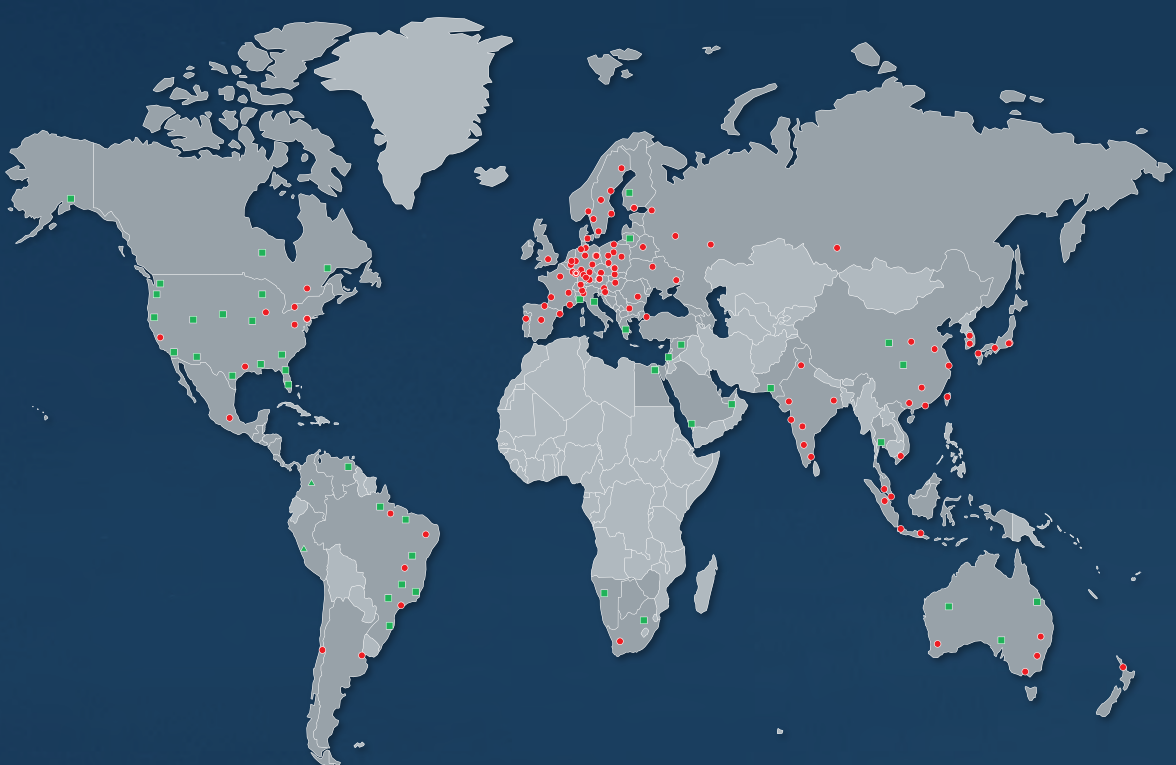

- HYDAC Head Office
- HYDAC Companies
- HYDAC Sales and Service Partners
- Free Sales Partners

HYDAC INTERNATIONAL

HYDAC INTERNATIONAL
GMBH

Industriegebiet
66280 Sulzbach/Saar
Germany

Tel.: +49 6897 509-01
Fax: +49 6897 509-577

E-mail: info@hydac.com
Internet: www.hydac.com