



## Hydraulic accumulators with back-up nitrogen bottles

### 1. GENERAL INFORMATION

To complete the accumulator range, HYDAC provides a variety of useful accessory products. They guarantee correct installation and optimum functioning of HYDAC hydraulic accumulators. They include nitrogen bottles which can be used to back up hydraulic accumulators. Nitrogen bottles used as back-ups increase the gas volume in the accumulator system. This means that smaller accumulators can be used for the same gas volume and costs can be reduced.

For further information, please turn to the sections:

- Bladder accumulators Standard design  
No. 3.201



- Piston accumulators Standard design  
No. 3.301



### 1.1. FURTHER INFORMATION

- Operating instructions for bladder accumulators  
No. 3.201.BA
- Operating instructions for diaphragm accumulators  
No. 3.100.BA
- Operating instructions for piston accumulators  
No. 3.301.BA

#### **The operating instructions must be observed!**

All work on HYDAC hydraulic accumulators must only be carried out by suitably trained staff. Incorrect installation or handling can lead to serious accidents.

Further information such as accumulator sizing, safety information and extracts from the acceptance specifications can be found in our overview catalogue section:

- HYDAC Accumulator Technology  
No. 3.000

This document and others are available from our Download Center at [www.hydac.com](http://www.hydac.com).

## 2. HYDRAULIC ACCUMULATORS AS BACK-UP VERSIONS

### 2.1. SET-UP USING THE EXAMPLE OF A BLADDER ACCUMULATOR

Based on bladder accumulator models 20 ... 50 l, the gas side of these accumulators has been specially designed to connect to nitrogen bottles. A diffuser rod prevents damage to the bladder when the accumulator is charged, see section 2.2. This design can also be used for the separation of fluids (taking into account the volume ratios which apply to bladder accumulators).

#### Example of back-up type 1

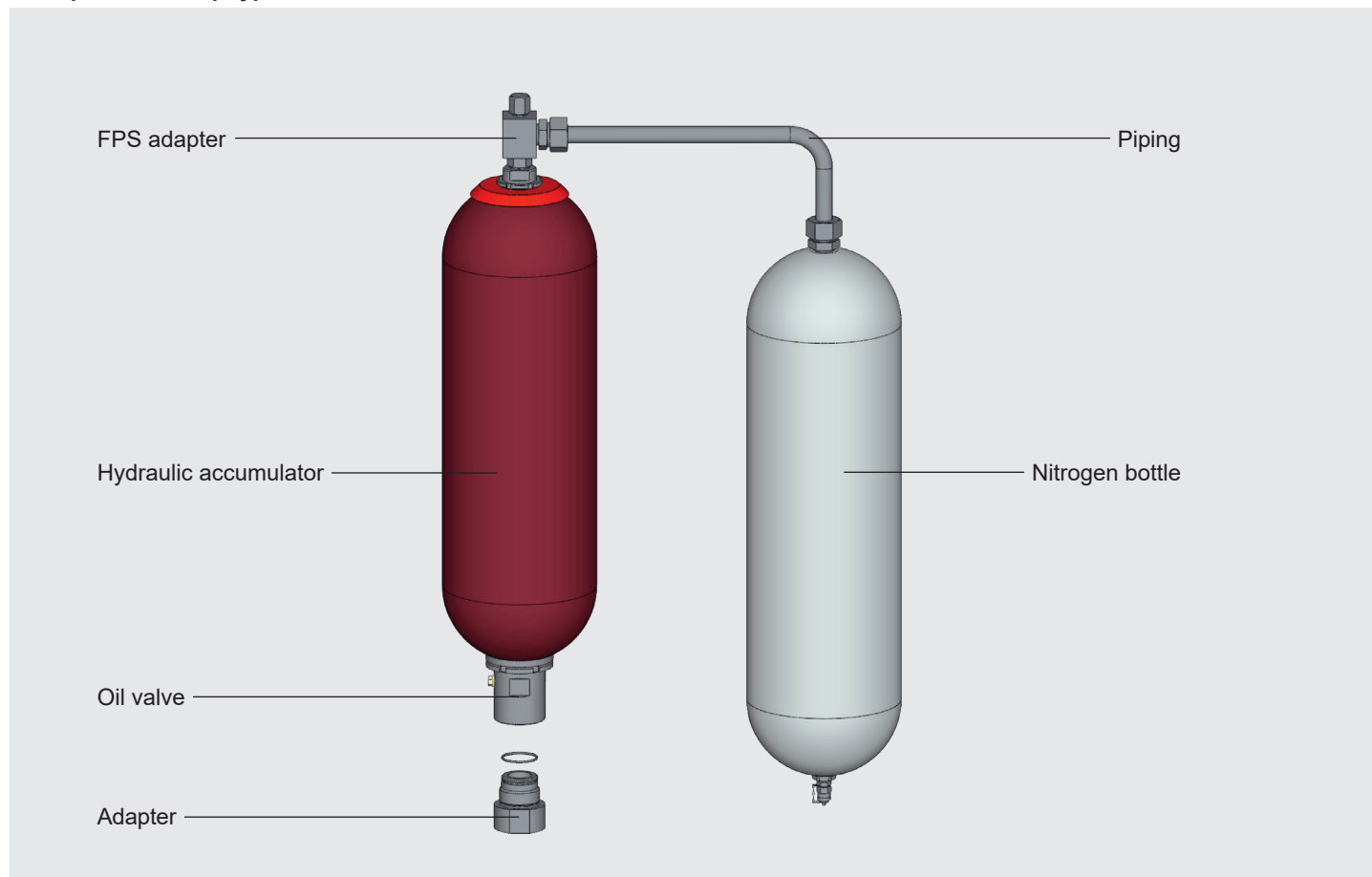

#### Example of back-up type 2

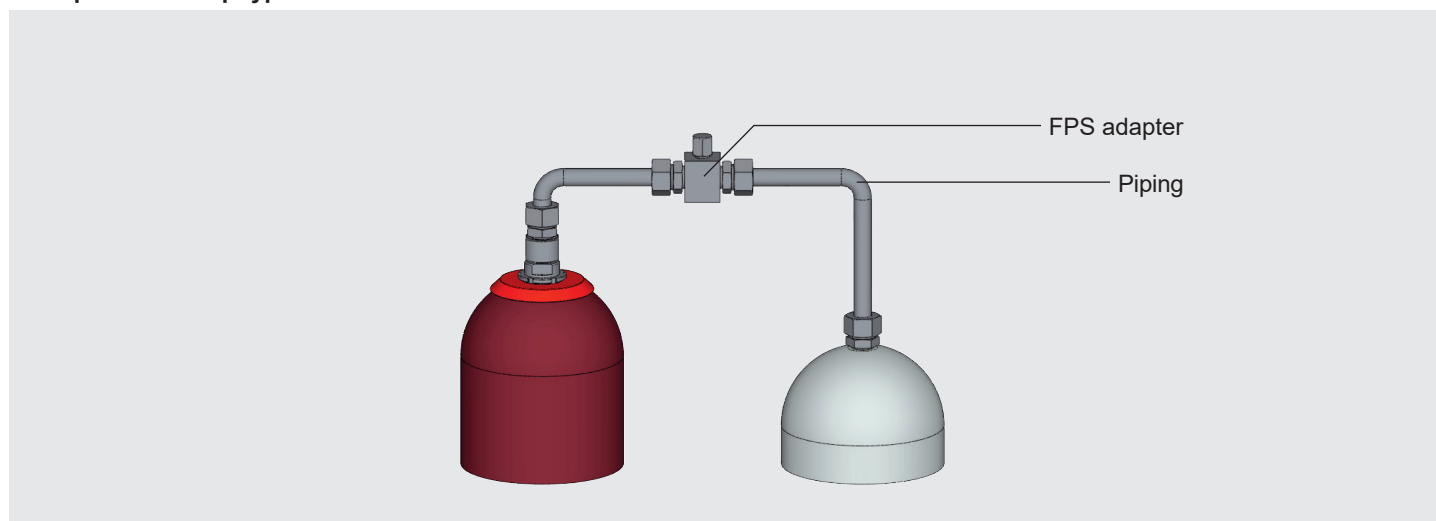

## 2.2. TABLES AND DRAWINGS

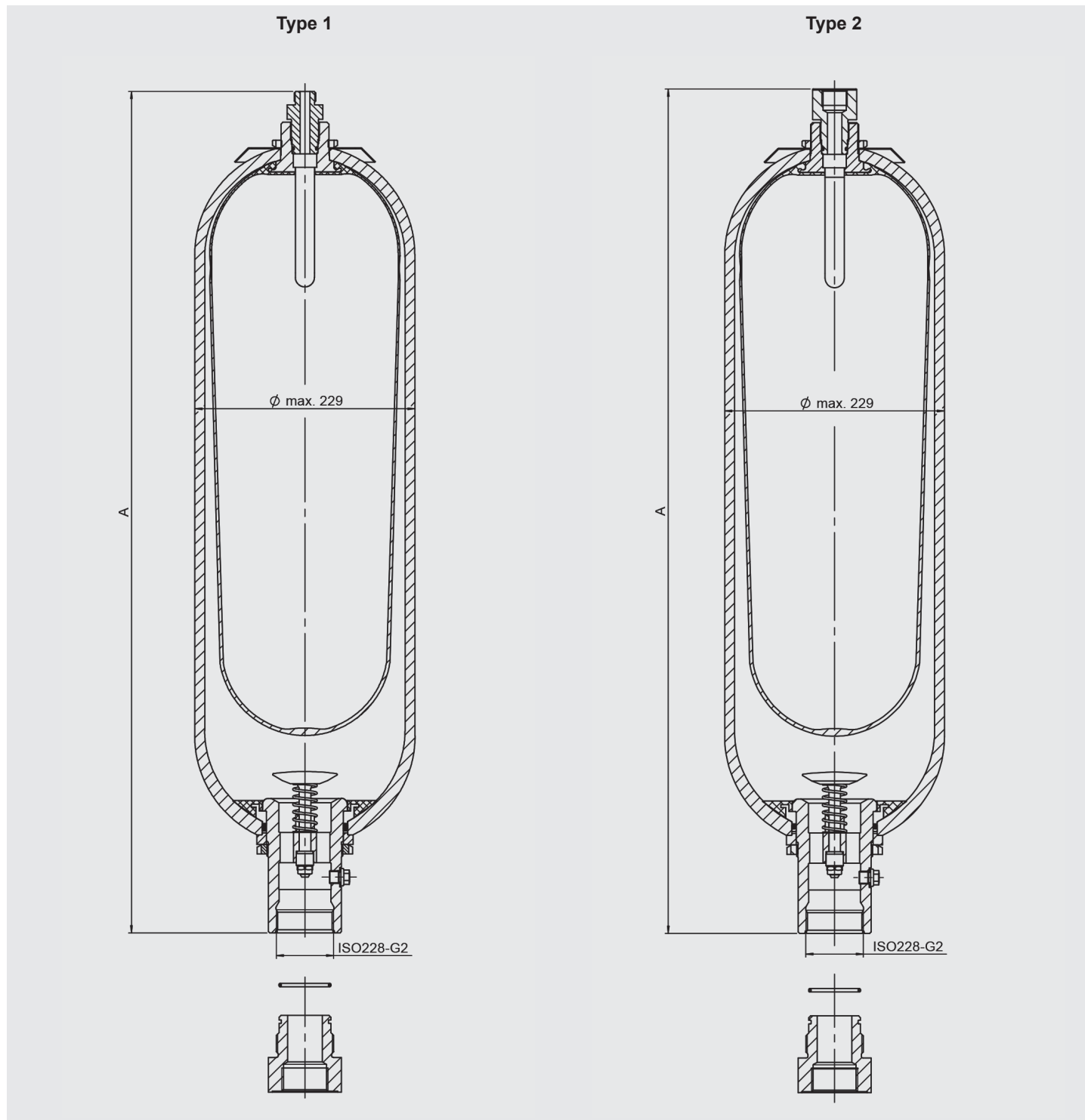

Nominal volume [l]	Effect. gas volume [l]	Weight [kg]	A max. [mm]	Part no.	
				Type 1	Type 2
20	17.5	53.5	905	3153006	3239334
24	24	72	1070	3280349	4481316
32	32.5	89	1420	3114824	3085838
50	47.5	119.5	1930	3079661	3082402

Others on request

## 2.3. SPARE PARTS

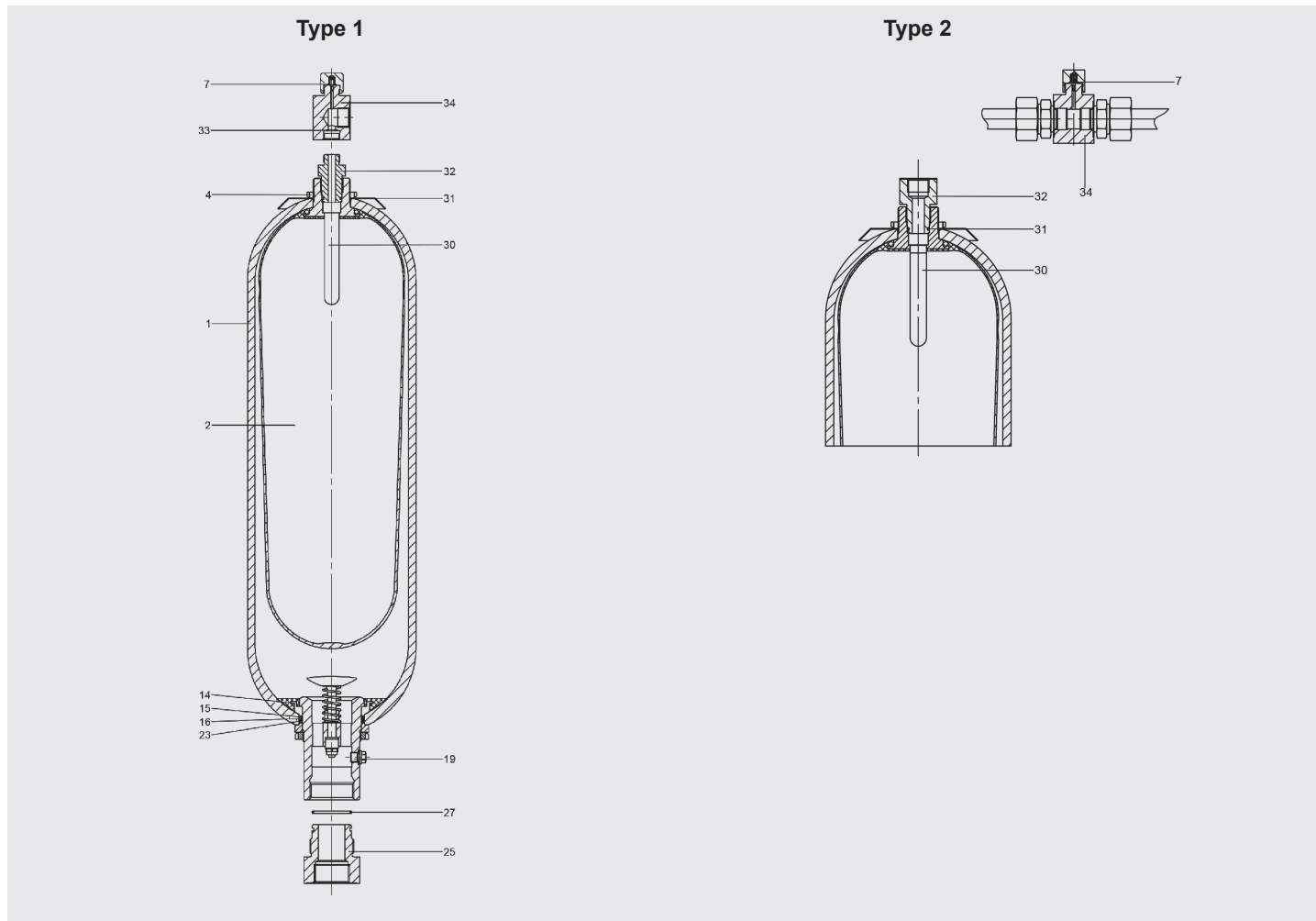

Description	Item
<b>Bladder assembly</b> consisting of:	
Bladder	2
Lock nut	4
Diffuser rod	30
O-ring 22x2.5 <sup>1)</sup>	31
Adapter for type 1/2	32
<b>Seal kit</b> consisting of:	
O-ring 7.5x2 <sup>1)</sup>	7
Washer	15
O-ring 80x5 <sup>1)</sup>	16
Vent screw	19
Support ring	23
O-ring 48x3 <sup>1)</sup>	27
<b>Repair kit</b> consisting of:	
Bladder assembly (see above)	
Seal kit (see above)	
O-ring 11x2 <sup>1)</sup>	33
Anti-extrusion ring	14
<b>FPS adapter for type 1/2 <sup>2)</sup></b>	<b>34</b>

### Recommended spare parts

<sup>1)</sup> Different dimensions for code 663 and 665

<sup>2)</sup> FPS adapter (item 34) available as an accessory, see section 4.2.

Accumulator shell (item 1) not available as a spare part

Vent screw (item 19) for NBR/carbon steel: Seal ring (item 20) integrated

Adapter (item 25) incl. O-ring (item 27) available as an accessory, see catalogue section: Bladder accumulators, Standard design No. 3.201, section 4.

Adapter (item 32) for type 1 standard

For other spare parts, see section 3.

NBR, carbon steel, standard gas valve

Nominal volume of accumulator [l]	Seal kit Part no.	Repair kit	
		Type 1 Part no.	Type 2 Part no.
20	3079398	3119500	3897464
24		3119502	3897463
32		3119498	3897462
50		3119499	3897461

### 3. NITROGEN BOTTLES

#### 3.1. DESCRIPTION

HYDAC nitrogen bottles are used for receiving and storing nitrogen.

HYDAC supplies various versions, such as standard nitrogen bottles made from forged vessels and special vessels based on bladder accumulator shells (SN...B), piston accumulator tubes (SN...K) and diaphragm accumulator halves (SN...M) – see catalogue sections:

- Bladder accumulators Standard design  
No. 3.201
- Piston accumulators Standard design  
No. 3.301
- Diaphragm accumulators  
No. 3.100

The following technical specifications refer to standard nitrogen bottles. Please ask us for information regarding other designs.

#### 3.2. DESIGN

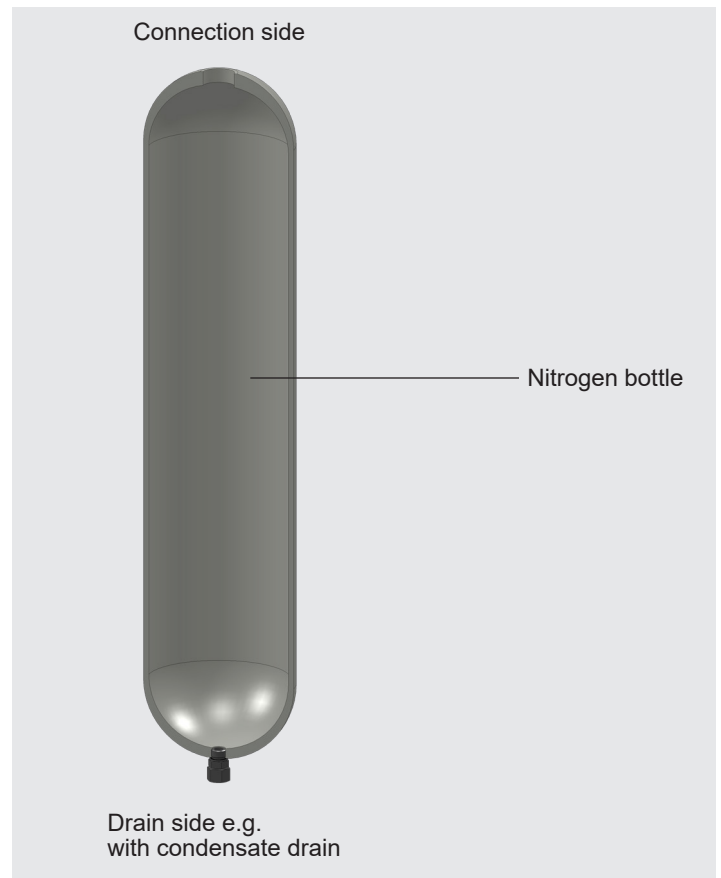

#### 3.3. ADVANTAGES

Using HYDAC nitrogen bottles provides the following advantages:

- Cost-effective increase in the accumulator volume and
- smaller accumulators for the same gas volume as a result.

### 3.4. MODEL CODE

Not all combinations are possible. Order example.  
For further information, please contact HYDAC.

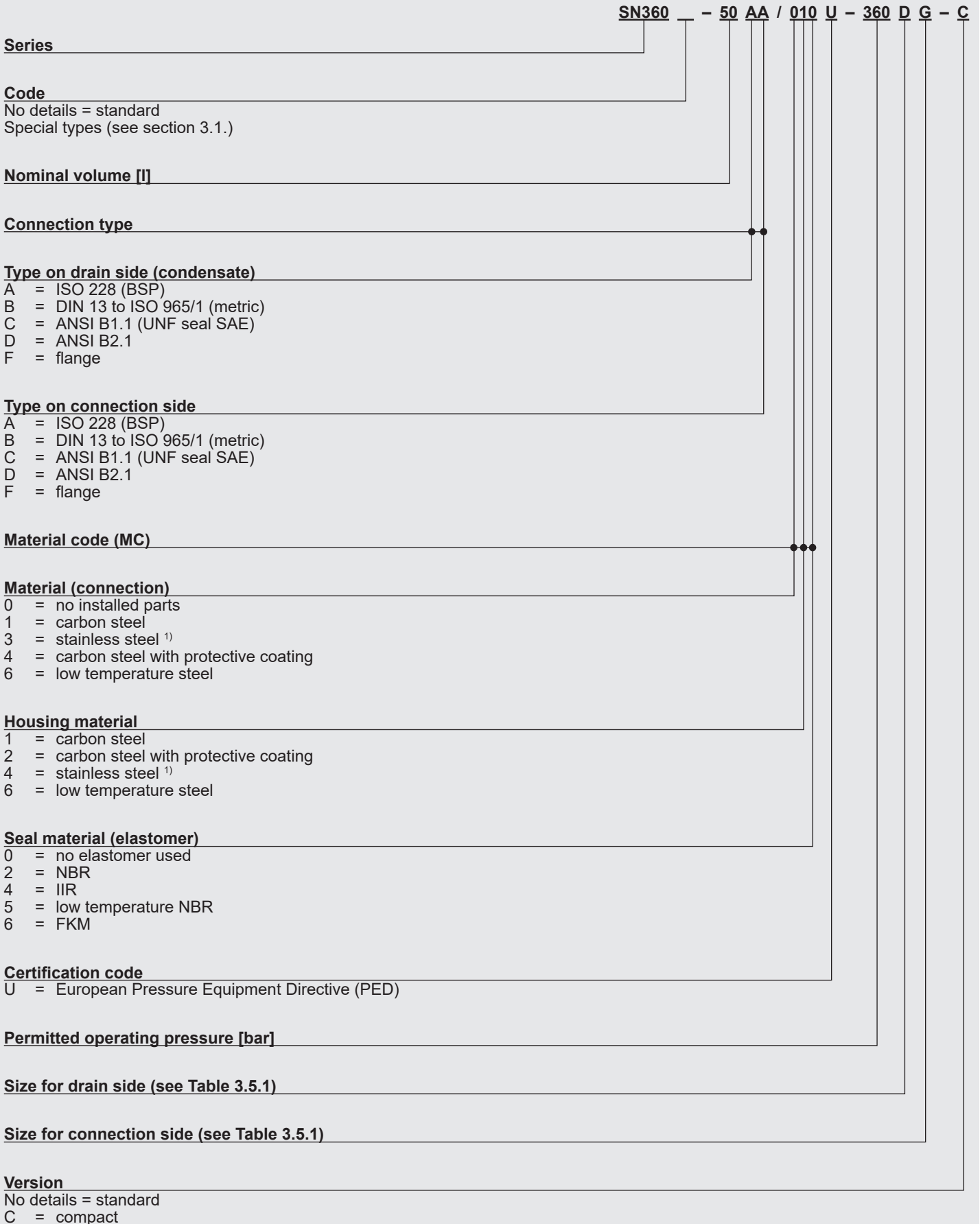

### 3.5. TABLES AND DRAWINGS

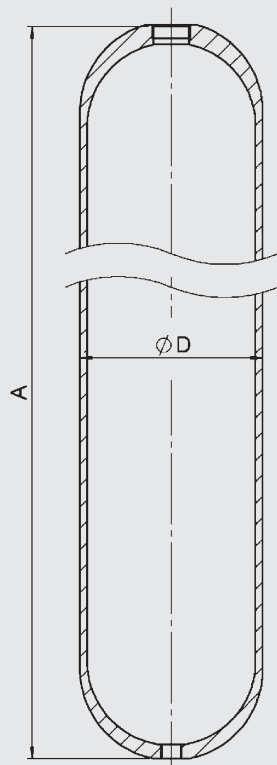

Fig. 1

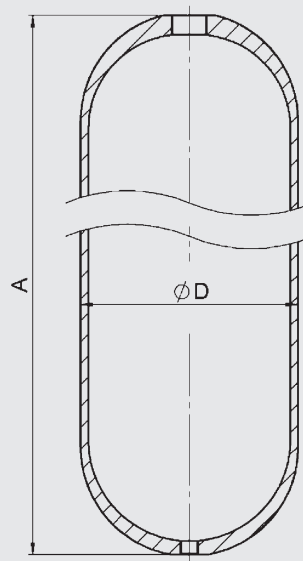

Fig. 2

Series	Volume [l]	Certification code	Connections to ISO 228 (Type AA)		A ± 25 [mm]	D ± 1% [mm]	Weight approx. [kg]	Part no.	Designation	Fig.
			Drain side	Connection side						
SN360	50	U	G 3/4	G 3/4	1590	229	89	3176324	SN360-50AA/010U-360DD	1
			G 3/4	G 1 1/2				3418347	SN360-50AA/010U-360DG	
		S	G 3/4	G 1 1/2				3987605	SN360-50AA/010S-210DG	
	75	U	G 3/4	G 1 1/2	2280	229	126	3561595	SN360-75AA/010U-360DG	1
			S	G 3/4				G 1 1/2	3987606	
		U	G 3/4	G 1 1/2	1690	273	124	3987162	SN360-75AA/010U-360DG-C	2
S			G 3/4	G 1 1/2				3987163	SN360-75AA/010S-200DG-C	
SN600	50	S	G 3/4	G 1 1/2	1730	241	143	3987613	SN600-50AA/010S-345DG	1
	75	S	G 3/4	G 1 1/2	2500	232	197	3987614	SN600-75AA/010S-345DG	1

### 3.5.1 Connections for SN360

The following connections are available for standard nitrogen bottles (see section 3.5.).

Standard connections are highlighted in grey. All other versions available on request (not all combinations are possible).

Type	A BSP ISO228	B Metric DIN13 ISO965/1	C SAE ANSI B1.1	D NPT ANSI B2.1	F Flange connection	
Size						
A	G 1/4"	M12x1.5	7/16"-20UNF	1/4"	1/2"	3000 psi, code 61
B	G 3/8"	M18x1.5	9/16"-18UNF	3/8"	3/4"	
C	G 1/2"	M22x1.5	3/4"-16UNF	1/2"	1"	
D	G 3/4"	M27x2	1 1/16"-12UN	3/4"	1 1/4"	
E	G 1"	M33x2	1 5/16"-12UN	1"	1 1/2"	
F	G 1 1/4"	M42x2	1 5/8"-12UN	1 1/4"	2"	6000 psi, code 62
G	G 1 1/2"	M48x2	1 7/8"-12UN	1 1/2"	1/2"	
H	G 2"	M14x1.5	2 1/2"-12UN	2"	3/4"	
I	G 1 3/4"	M8	-	-	-	
K	-	M16x1.5	-	-	1 1/4"	
L	-	-	7/8"-14UNF	5/8"	1 1/2"	
M	-	-	-	-	2"	
S	Special design					

## 4. ACCESSORIES

### 4.1. F + P CHARGING AND TESTING BLOCK

#### 4.1.1 Description

The HYDAC F + P charging and testing block is used to charge and test back-up type hydraulic accumulators. It has connections for the FPU-1 charging and testing unit and for pressure gauges. As a safety function, a GSV6 gas safety valve can be fitted (see catalogue section given below). In addition, it allows the back-up nitrogen bottles to be shut off from the hydraulic accumulator.

- Safety equipment for hydraulic accumulators  
No. 3.552

#### 4.1.2 Hydraulic circuit with charging and testing block

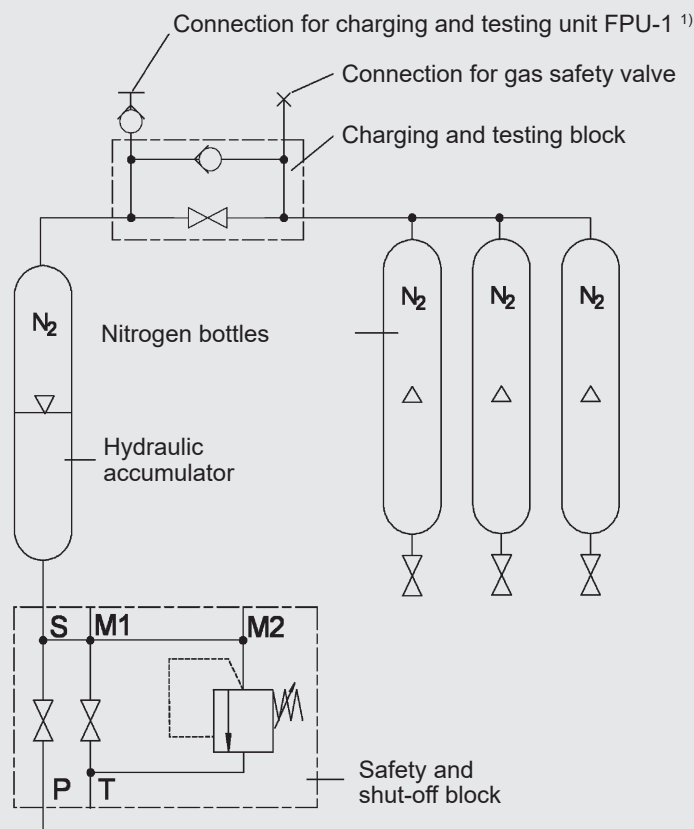

<sup>1)</sup> For further information, see catalogue section:

- FPU charging and testing unit  
No. 3.501



### 4.1.3 Model code

	<b>F+P - 16 - 20SR - 6112 - 12X - A - ...</b>
<b>Series</b>	
<b>Nominal size</b>	
<b>Connection type</b> To DIN 2353	
<b>Material code (MC)</b>	••••
<b>Housing material</b> 6 = carbon steel	
<b>Material of ball and spindle</b> 1 = carbon steel	
<b>Material of sealing cups (ball seal)</b> 1 = POM	
<b>Material of seals</b> 2 = NBR	
<b>Switching handle</b> 02X= enclosed unassembled 12X= mounted	
<b>Protective coating</b> No details = no protective coating A = zinc-plated	
<b>Additional details</b> e.g. GSV-MV = with redundant protection against excessive pressure increase. For further technical details, see product information No. 10000794442	

### 4.1.4 Standard item

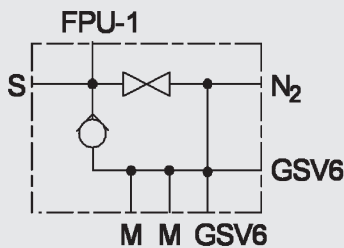

Fig 1

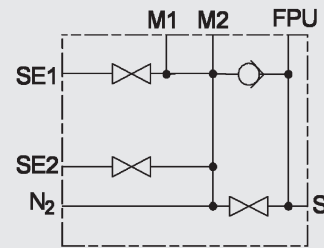

Fig 2

Carbon steel, NBR

Designation	Max. operating pressure [bar]	Weight [kg]	Part no.	Seal kit <sup>1)</sup>	Fig.
F+P-16-20SR-6112-12X	400	4.3	850233	2115776	1
F+P-32-38SR-6112-12X	350	14	552193	2112088	1
F+P-32-38SR-6112-12X-A-GSV-MV	350	21.4	4241832	2112088	2

<sup>1)</sup> Recommended spare parts

## 4.1.5 Dimensions

### Charging and testing block dn 16

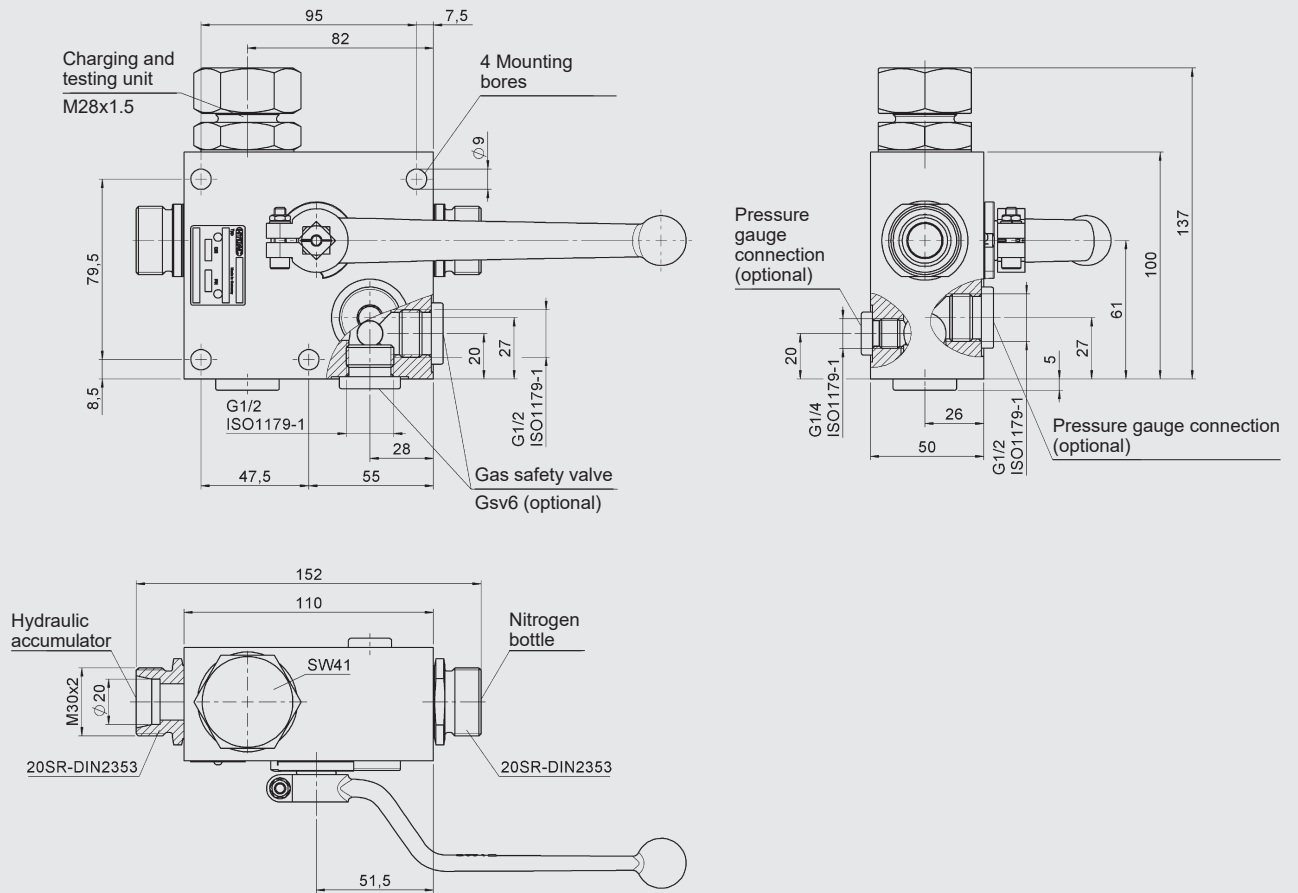

### Charging and testing block dn 32

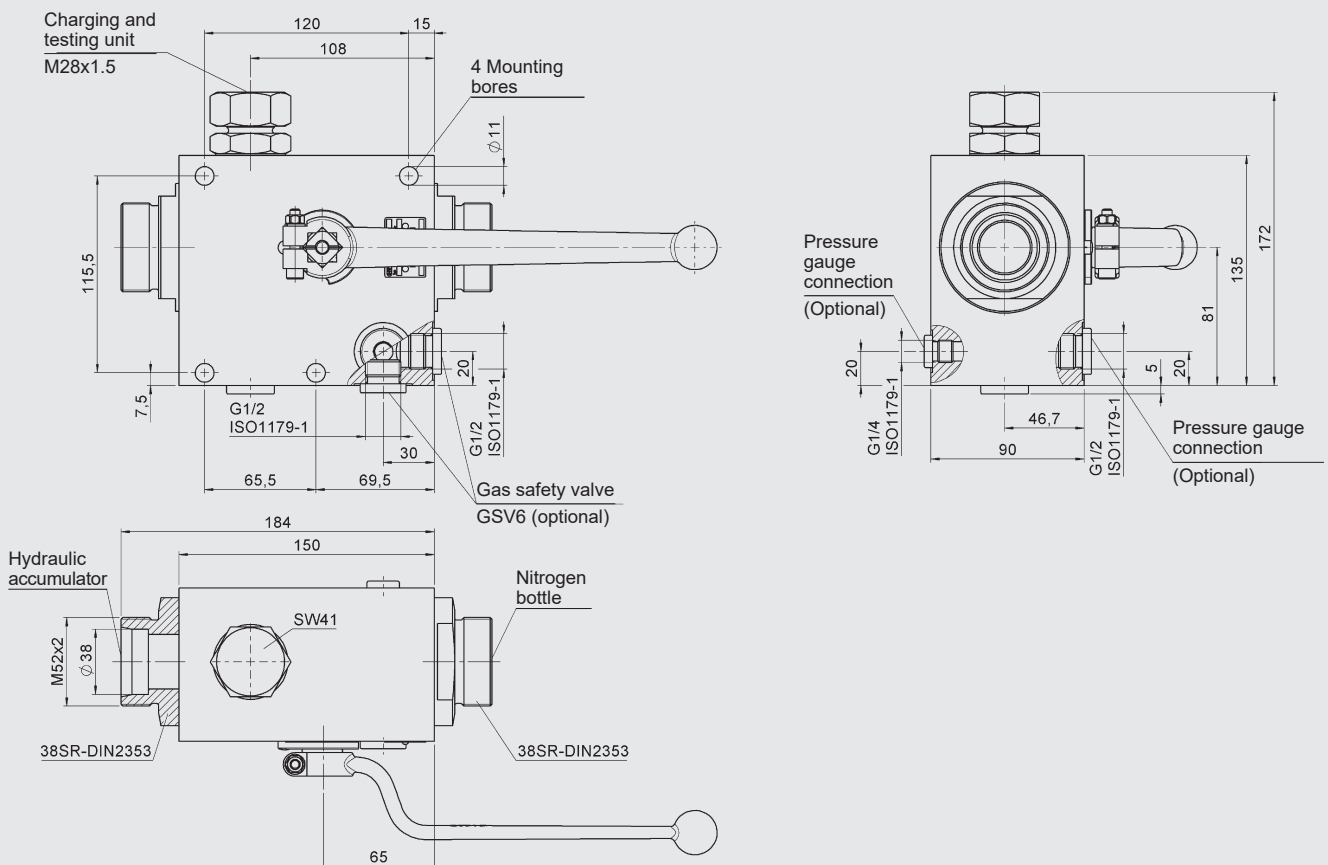

## 4.2. FPS ADAPTER

The HYDAC FPS adapter is used to charge back-up type hydraulic accumulator systems. For this purpose, it has a connection for the FPU-1 charging and testing unit.

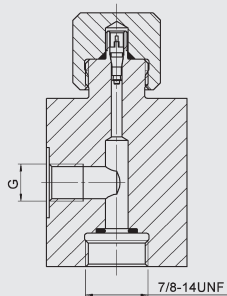

Fig 1

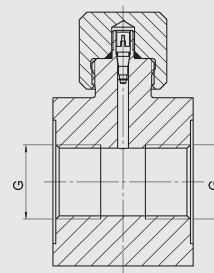
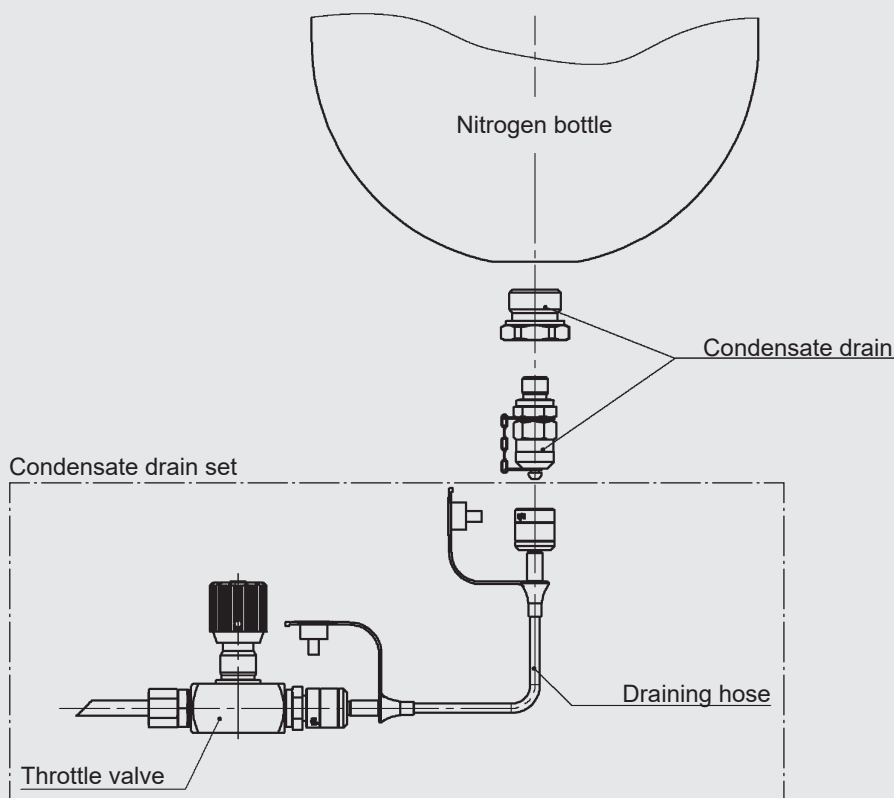

Fig 2

Designation	G ISO 228	Part no.	Fig.
Adapter FPS 7/8-14UNF	G 3/4	363226	1
Adapter FPS	G 3/4	243218	2

## 4.3. CONDENSATEDRAIN SET

The condensate drain set consists of a throttle valve and a suitable condensate draining hose. It is used to drain any condensate from the nitrogen bottle, in a controlled way.



Designation	Length [m]	Part no.
Condensate drain G 3/4 – Minimes M16x1.5	–	3219496
Condensate drain set	0.4	3472820
	1	3472823
	1.6	3472824

## 4.4. NITROGEN CHARGING UNIT



HYDAC nitrogen charging units make it possible to rapidly and inexpensively charge or test the required gas pre-charge pressures in bladder, piston and diaphragm accumulators. They guarantee an optimal utilisation of standard commercial nitrogen bottles up to a residual pressure of 20 bar and a maximum pre-charge pressure of 350 bar. Portable, mobile and stationary N<sub>2</sub>-Server versions are available.

For further details and technical data, see the following brochure:

- Nitrogen charging units N<sub>2</sub>-Server  
No. 2.201

Higher pressures available on request.

## 5. NOTE

The information in this brochure relates to the operating conditions and fields of application described. For applications and/or operating conditions not described, please contact the relevant technical department. Subject to technical modifications.

**HYDAC Technology GmbH**  
Industriegebiet  
**66280 Sulzbach/Saar, Germany**  
Tel: +49 68 97 / 509 - 01  
Internet: [www.hydac.com](http://www.hydac.com)  
E-mail: [speichertechnik@hydac.com](mailto:speichertechnik@hydac.com)