



## Safety equipment for hydraulic accumulators

### 1. DESCRIPTION

#### 1.1. SECURING PRESSURE VESSELS

Hydraulic accumulators are pressure equipment, as defined by the European Pressure Equipment Directive (PED), and as such their manufacture is subject to the statutory regulations.

For safety in the workplace, system manufacturers and operators must draw up risk assessments for the particular site. These must take possible risks at the installation site into account as well as risks in combination with external factors.

Fundamental risks affecting hydraulic accumulators are:

- Excessive pressure
- Temperature increase (e.g. in event of an external fire)

HYDAC provides the appropriate safety equipment to protect hydraulic accumulators from the maximum permitted operating pressure PS being exceeded on the gas and fluid side; see also catalogue section:

- HYDAC Accumulator Technology  
No. 3.000



When selecting safety equipment, consideration must be given to the material (elastomers and housing material) in terms of the material compatibility with the application.

The response pressure of safety equipment must **not** exceed the max. permitted operating pressure PS of a hydraulic accumulator.

## 1.2. FURTHER INFORMATION

- Operating instructions for GSV/GMP  
No. 3.504
- Operating instructions for GSB  
No. 3.505.BA

### The operating instructions must be observed!

All work with HYDAC safety devices must only be carried out by suitably trained staff. Incorrect installation or handling can lead to serious accidents.

Further information such as accumulator sizing, safety information and extracts from the acceptance specifications can be found in our overview catalogue section:

- HYDAC Accumulator Technology  
No. 3.000

This document and others are available from our Download Center at [www.hydac.com](http://www.hydac.com).

## 1.3. OVERVIEW

### 1.3.1 Protection on the gas side

Type of protection	What is protected?
Burst disc	Excessive pressure increase
Temperature fuse	Excessive temperature increase
Gas safety valve	Unexpected pressure increase

### Gas safety block

A gas safety block simplifies the handling of hydraulic accumulators on the gas side and thanks to its diverse connection options it is also able to hold the above-mentioned safety devices.

### 1.3.2 Protection on the fluid side

The fluid side must be protected from pressures exceeding the permitted operating pressures by installing approved and appropriate safety valves.

HYDAC offers pressure relief valves (DB12) which have a response pressure of up to 400 bar (set by HYDAC). The valve bears the CE marking, is built into safety and shut-off blocks in the series DSV10 and SAF in nominal sizes DN10 to DN50 and is lead-sealed.

Further information is available from the following catalogue section:

- SAF/DSV safety and shut-off block  
No. 3.551



## 2. BURST DISC

### 2.1. DESIGN

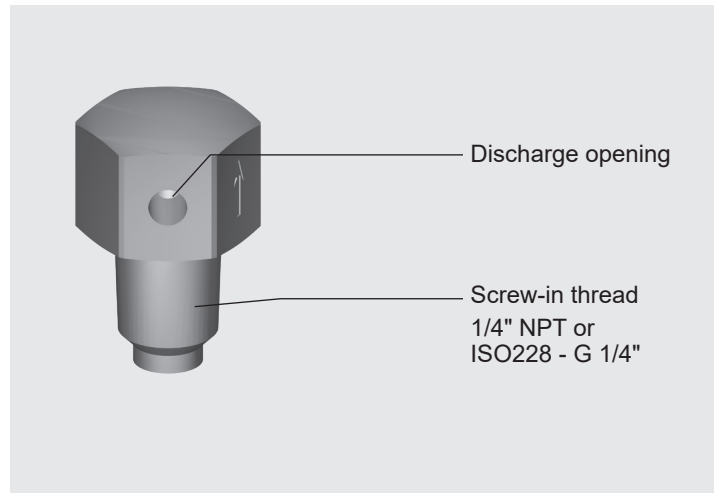

### 2.2. FUNCTION

If the pressure exceeds the permitted level, the burst disc is destroyed, permanently opening the port. This reduces the gas pressure by discharging the nitrogen completely.

Burst discs are designed for different response pressures and are supplied with a declaration of conformity.

Burst discs are made either entirely of stainless steel, or from an alloy based on stainless steel and nickel.

### 2.3. STANDARD ITEM

Burst disc, welded, with declaration of conformity to PED DN5

Designation	Burst pressure ± 10 % at 50 °C	Part no.	Mass flow <sup>2)</sup>
Burst disc plug 1/4" NPT	210 bar	3156148	1950
	250 bar	3156150	2320
	300 bar	3156151	2782
	330 bar	<b>3341280</b> <sup>1)</sup>	3059
	350 bar	3156152	3244
Burst disc plug ISO 228 G 1/4"	210 bar	3516441	1950
	330 bar	3560189	3059
	400 bar	3358418	3706

<sup>1)</sup> Preferred models

<sup>2)</sup> Theoretically calculated values

Others on request

Burst disc, clamped, with declaration of conformity to ASME VIII, Div. 1 and UD stamp  
DN 15, 1/2" NPT  
on request

## 2.4. ACCESSORIES

### 2.4.1 Adapter for bladder accumulators

To protect standard and low pressure bladder accumulators, the adapter shown below must be ordered with the burst disc:

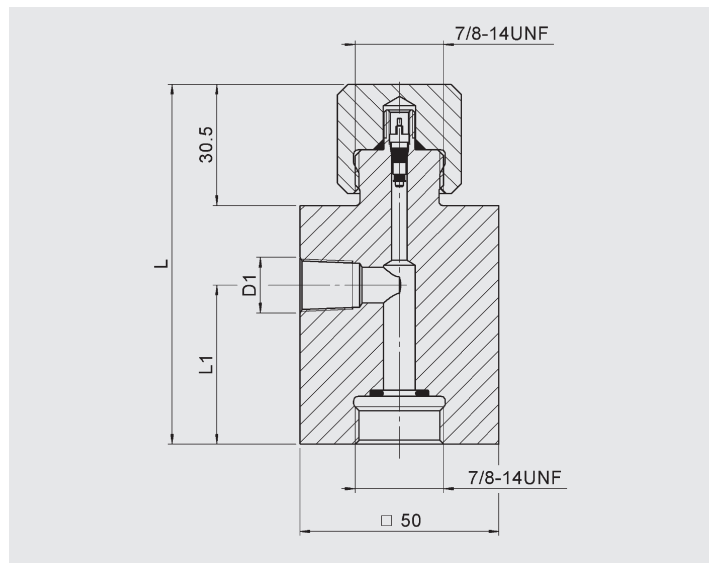

L [mm]	L1 [mm]	D1	Carbon steel	Stainless steel
90.5	40	1/4" NPT	366694	–
81.5	30	1/4" NPT	–	3117711
90.5	40	ISO 228 G 1/4"	364802	–
81.5	30	ISO 228 G 1/4"	–	3521154

### 2.4.2 Adapter for piston and diaphragm accumulators

To protect piston and diaphragm accumulators, the adapter shown below must be ordered with the burst disc:

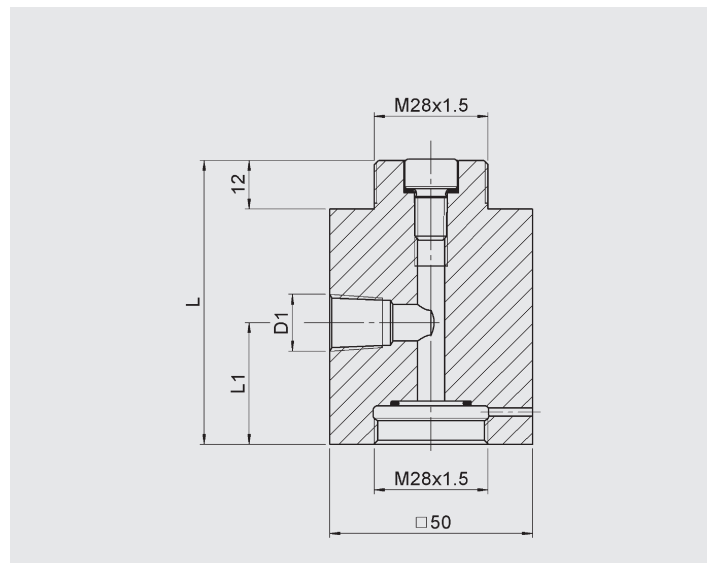

L [mm]	L1 [mm]	D1	Carbon steel	Stainless steel
70	30	1/4" NPT	3344645	–
		1/4" NPT	–	4329253
		ISO 228 G 1/4"	4286781	–
		ISO 228 G 1/4"	–	3564669

### 3. TEMPERATURE FUSE

HYDAC offers two different kinds of temperature fuse. In addition to the temperature fuse in carbon steel and stainless steel, which is suitable for bladder accumulators, HYDAC offers a type GMP6 temperature fuse, which is approved according to the European Pressure Equipment Directive (PED). It is made of stainless steel and has a CE marking.

#### 3.1. FUNCTION

Temperature fuses are "devices with a safety function" and are used to release the gas pressure by discharging the nitrogen completely when an increase in temperature reaches unacceptable levels (e.g. in the case of fire).

#### Installation instructions

Simple to retrofit by replacing the sealing cap with the temperature fuse. When mounting the GMP6 temperature fuse, the operating instructions must be observed, see section 1.2.

#### 3.2. DESIGN

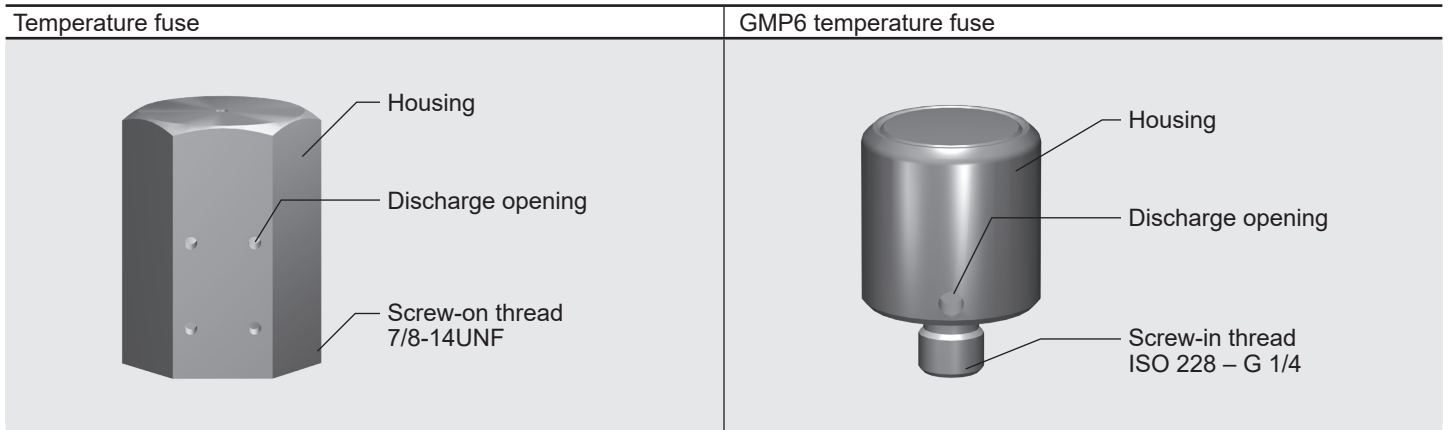

#### 3.3. STANDARD ITEMS AND TECHNICAL DATA

Type	Temperature fuse	GMP6 temperature fuse
Standard types	<b>363501</b> <sup>1)</sup>	Temperature fuse 7/8-14UNF
	<b>3094166</b> <sup>1)</sup>	Temperature fuse 7/8-14UNF with eye bolt (for crane hook)
		3517438
		3521196
		3584817
		GMP6-10-CE1637... with adapter for bladder accumulators
		GMP6-10-CE1637... with adapter for piston and diaphragm accumulators
Permitted operating pressure	≤ 450 bar	50 ... 420 bar
Temperature range	-10 °C ... +80 °C	-40 °C ... +120 °C <sup>2)</sup>
Melting temperature	Between +160 °C and +170 °C	Between +160 °C and +170 °C
CE marking	Not available	Available

<sup>1)</sup> Preferred models

<sup>2)</sup> With adapter restricted temperature range -10 °C ... +80 °C

## 4. GAS SAFETY VALVE

### 4.1. FUNCTION

The gas safety valve protects the hydraulic accumulator by reducing the pressure in a controlled way **if pressure exceeds the permitted level unexpectedly** (regular triggering of the GSV6 can lead to leakage at the valve). It is pre-set on the pressure side and lead-sealed by the authorised representative. It is also supplied with a declaration of conformity and a type approval.

### 4.2. DESIGN

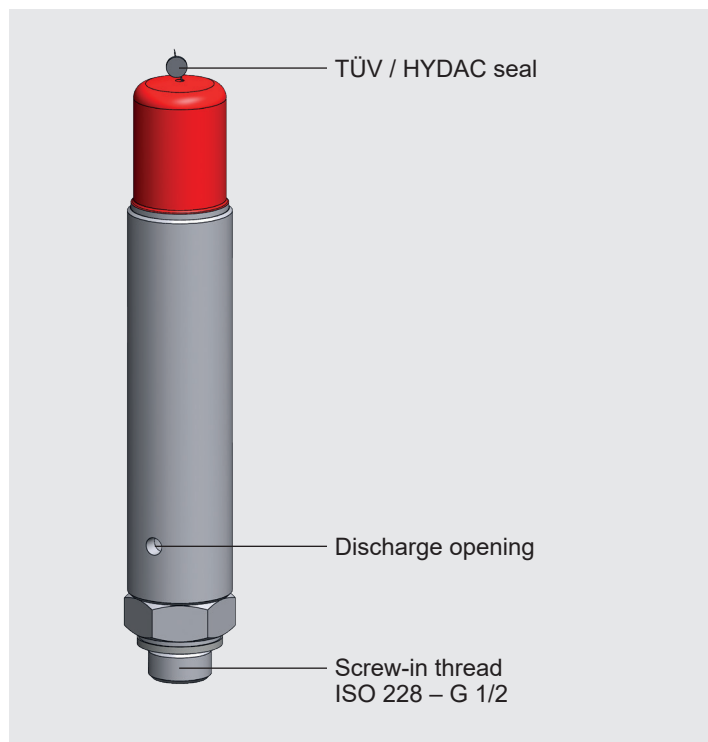

### 4.3. MODEL CODE

(also order example)

**GSV6 - 1 0 - CE1637.ENISO4126-1.6.G. 195. 330**

**Gas safety valve**

**Series**

- 1 = standard with 2 discharge openings, nominal size 6 mm
- 2 = 1 discharge opening ISO 228 – G 1/2

**Temperature range**

- 0 = -20 °C ... +80 °C
- 5 = -40 °C ... +80 °C (low temperature)

**Component code**

**Outlet mass flow  $Q_m$  [kg/h]**

(see table, section 4.4.2)

**Response pressure  $p$  [bar]**

(see table, section 4.4.2)

## 4.4. STANDARD ITEMS

### 4.4.1 Technical data

#### Dimensioning

European Pressure Equipment Directive (PED), EN ISO4126-1, EN 764-7, others on request

#### Module category

IV to European Pressure Equipment Directive (PED)

Module B + D (EU-type examination)

Module G (unit verification) on request

#### Nominal size

6 mm

#### Outlet mass flow

See section 4.4.2

#### Material

Stainless steel, closing element with flexible seat seal

#### Medium

Nitrogen (N<sub>2</sub>)

#### Operating pressure range

30 ... 370 bar

#### Temperature range

-20 °C ... +80 °C, others on request

#### Weight

1.1 kg

#### Installing the GSV gas safety valve

The self-centring steel-elastomer seal ring means that this valve can be installed simply and securely in any position.

See section 1.2.

### 4.4.2 Tables and drawings

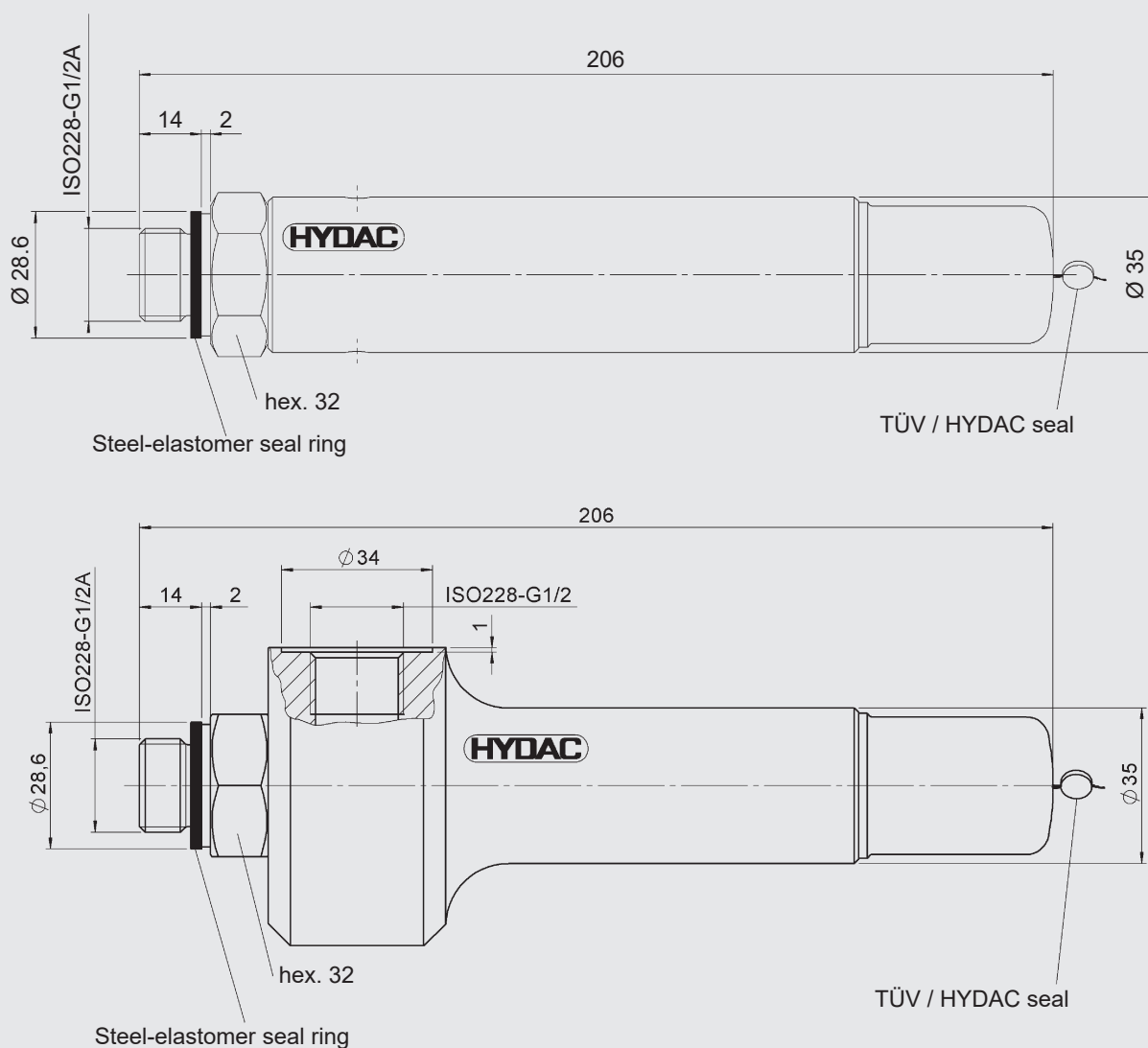

Selection of the response pressure (p) of the gas safety valve is based on the maximum operating pressure of the hydraulic accumulator, according to the application.

Q <sub>m</sub> [kg/h]	p [bar]	Part no. <sup>1)</sup>
15	30	3123965
20	40	3123966
28	50	3123967
35	60	3124028
40	70	3124029
45	80	3124030
50	90	3124031
58	100	3124032
65	110	3124033
70	120	3124034
75	130	3124035
83	140	3124036
88	150	3124037
95	160	3124038
100	170	3124039
105	180	3124040
110	190	3124041
118	200	3124042
125	210	3124043
130	220	3124044
135	230	3124045
140	240	3124046
148	250	3124047
155	260	3124048
160	270	3124049
165	280	3124050
170	290	3124051
178	300	3124052
185	310	3124053
190	320	3124054
195	330	3124055
200	340	3124056
205	350	3124057

<sup>1)</sup> Others on request

> 350 bar = additional price required for EC unit verification, please ask

## 4.5. ACCESSORIES

### 4.5.1 Adapter for bladder accumulators

To protect standard or low pressure bladder accumulators, the adapter shown below must be ordered with the GSV6 gas safety valve:

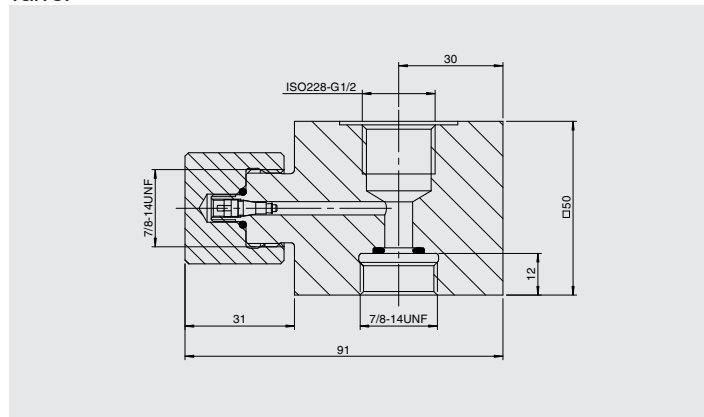

Designation	Part no.
Adapter assembly for bladder accumulators	2103381

Others on request

### 4.5.2 Adapter for piston and diaphragm accumulators

To protect piston and diaphragm accumulators, the adapter shown below must be ordered with the GSV6 gas safety valve:

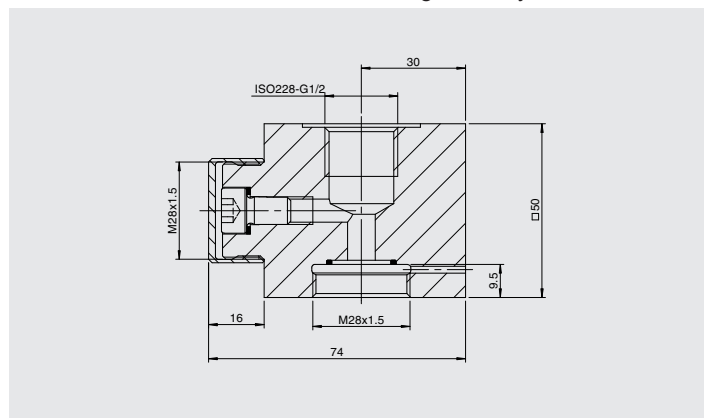

Designation	Part no.
Adapter assembly for piston and diaphragm accumulators	3423339

Others on request

## 5. GAS SAFETY BLOCK

### 5.1. FUNCTION

The GSB450 is an adapter block which is mounted on a hydraulic accumulator on the gas side and which can be fitted with various pressure devices, charging equipment, safety valves and other safety components.

#### Charging and testing

The procedure for charging and testing is described in the operating instructions. The shut-off valve (V1) must always be closed following the charging and testing procedure. The pressure side at the release valve (V2) must then be depressurised to protect the connected fittings and components from a permanent pressure load.

#### Permanent monitoring

To permanently monitor the accumulator pre-charge pressure, a pressure switch/pressure transmitter can be screwed into connection A2.

For other configurations, please enquire with us.

### 5.2. DESIGN

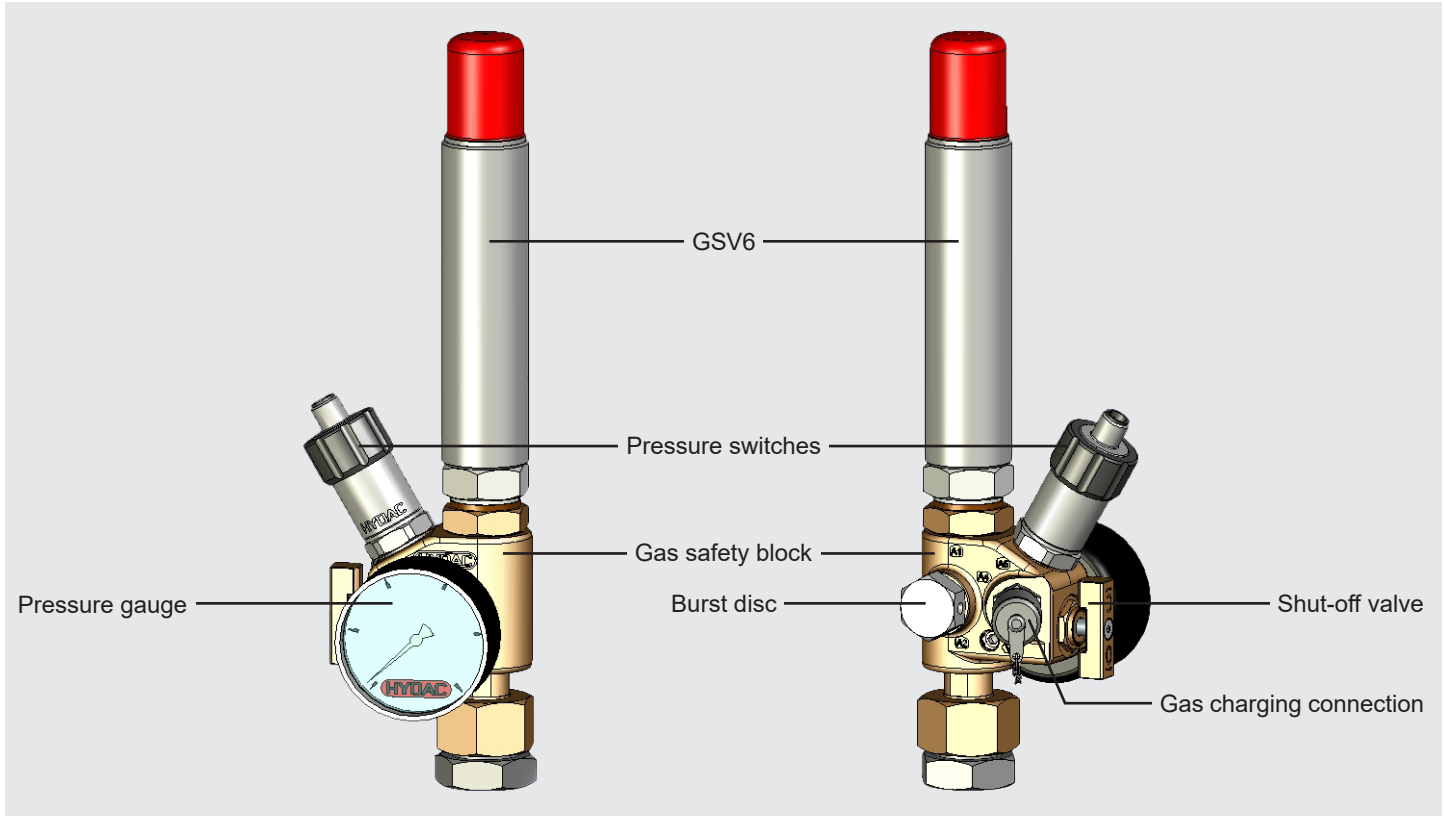

The gas safety block GSB450 consists of a brass block (other materials on request) with an integrated vent valve and shut-off valve and connections for:

- Pressure gauge
- Gas safety valve (GSV6)
- Gas charging valve (e.g. Minimess)
- Pressure transmitter or pressure switch
- Burst disc or temperature fuse

The gas safety valve connection is designed as a check valve. Therefore, the valve can be changed even if the system is pressurised. The version shown in the diagram is an example. Information on the standard design of the GSB450 is provided in section 5.3.

### 5.3. VERSION

The GSB450 is delivered with the following as standard:

- Shut-off valve
- Release valve
- Pressure gauge (0 - 400 bar, Ø 63 mm)
- Gas charging connection, code 1 (Minimess threaded coupling, series 1620, M16x2)

Options are listed in section 5.7., others on request.

### 5.4. ADVANTAGES

- Compact design
- Flexible connection options
- Variable indication options: bar, MPa or psi, analogue or digital (optional)
- The direction that the pressure indicator is facing can be individually adjusted
- Accumulator can be charged with nitrogen, directly via Minimess valve
- Pre-charge pressure can be checked without FPU-1



## 5.5. MODEL CODE

(also order example)

**GSB450 - 1 - 1 - 5 - 1 - 1 - 350**

### Series

### Material

- 1 = standard (brass and add-on parts in carbon steel)
- 2 = stainless steel (brass and add-on parts in stainless steel)
- 3 = stainless steel (on request)

### Accumulator connection

- 1 = connection for SK/SBO
- 2 = connection for SB 7/8-14UNF
- 3 = connection for SB 5/8-18UNF
- 8 = connection for threaded pipe fitting to ISO 8434-1 (OD 16, heavy duty)
- 9 = special connection (on request)

### Pressure gauge display

- 0 = none
- 1 = 0 - 25 bar
- 2 = 0 - 100 bar
- 3 = 0 - 160 bar
- 4 = 0 - 250 bar
- 5 = 0 - 400 bar
- 9 = special pressure gauge (e.g. different pressure units or with glycerine filling)

### Gas charging connection

- 0 = none
- 1 = Minimes valve M16x2 (NBR seal)
- 2 = Minimes valve M16x1.5 (FKM seal)
- 3 = Minimes valve M16x1.5 (gas-tight, stainless steel 1.4104) for permanent monitoring (see section 5.6.2)
- 9 = special connection

### Safety devices

- 0 = none
- 1 = gas safety valve GSV6
- 2 = burst disc
- 3 = temperature fuse GMP6

### Pressure range of the safety equipment

## 5.6. STANDARD ITEMS

### 5.6.1 Technical data

#### Medium

Nitrogen (N<sub>2</sub>)

#### Permitted operating temperature

-20 °C ... +80 °C

#### Max. operating pressure

400 bar / 5800 psi

#### Accumulator connection

Bladder accumulator:  
7/8-14UNF with adapter

For bladder accumulators, the appropriate adapter is supplied. All other connections are sealed with locking screws.

Piston and diaphragm accumulators:  
M28x1.5

For piston and diaphragm accumulators the connection is a lock nut with M28x1.5 thread as standard.

#### Weight

- Standard design for SB  
1.6 kg
- Standard design for SBO and SK  
1.5 kg

## 5.6.2 Tables and drawings

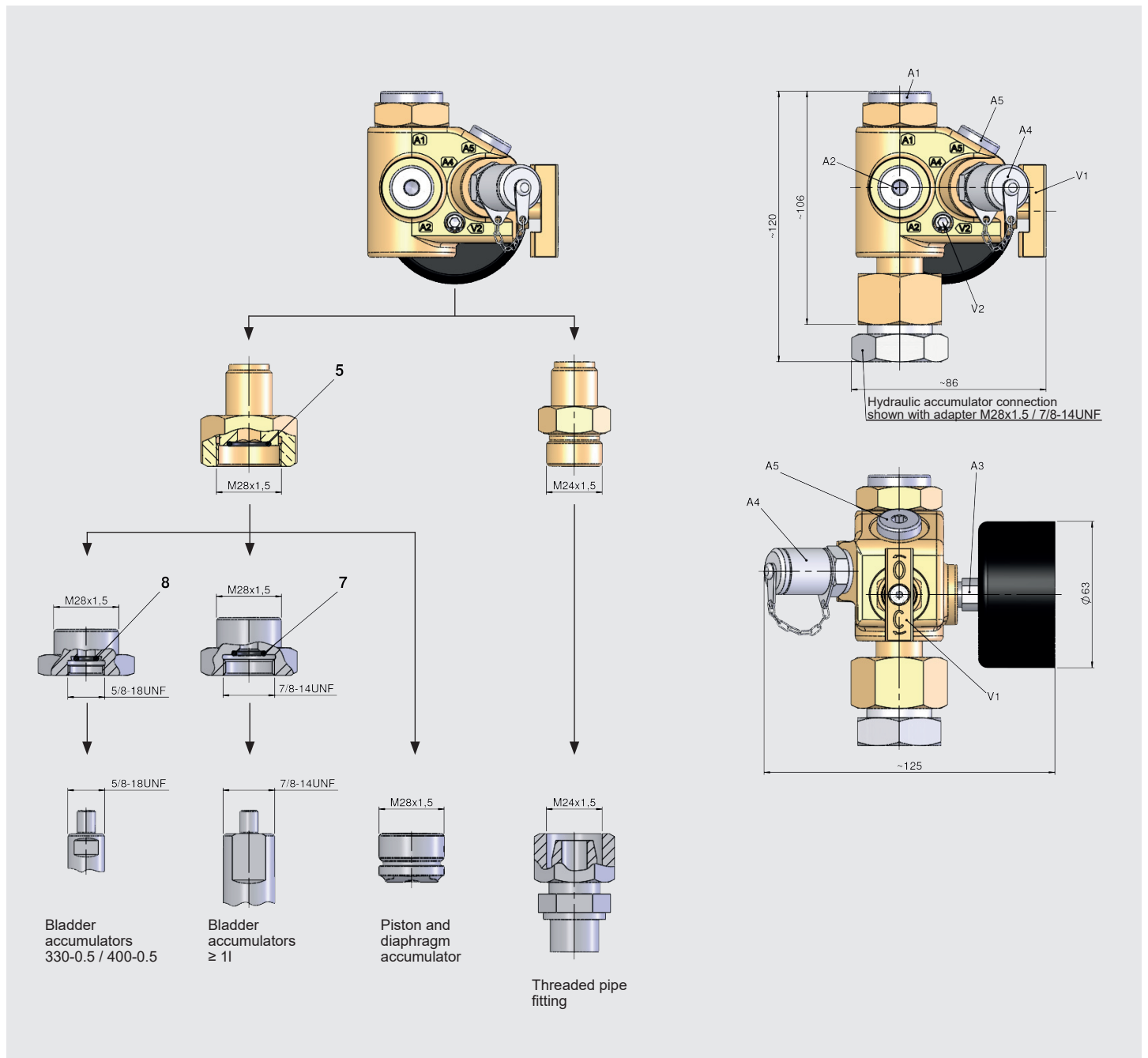

Designation	Part no.
GSB450-1-1-1-1-0	3534710
GSB450-1-1-2-1-0	3534711
GSB450-1-1-3-1-0	3534712
GSB450-1-1-4-1-0	3528946
GSB450-1-1-5-1-0	3426882
GSB450-1-2-1-1-0	3534713
GSB450-1-2-2-1-0	3534714
GSB450-1-2-3-1-0	3484861
GSB450-1-2-4-1-0	3433824
GSB450-1-2-5-1-0	3426905

### Installation instructions

The gas safety block can be mounted simply by swapping the sealing cap and the GSB450. To mount the GSB450, the operating instructions must be observed, see section 1.2.

### 5.6.3 Spare parts

The following spare parts for the GSB450 relate to the standard version: carbon steel / NBR

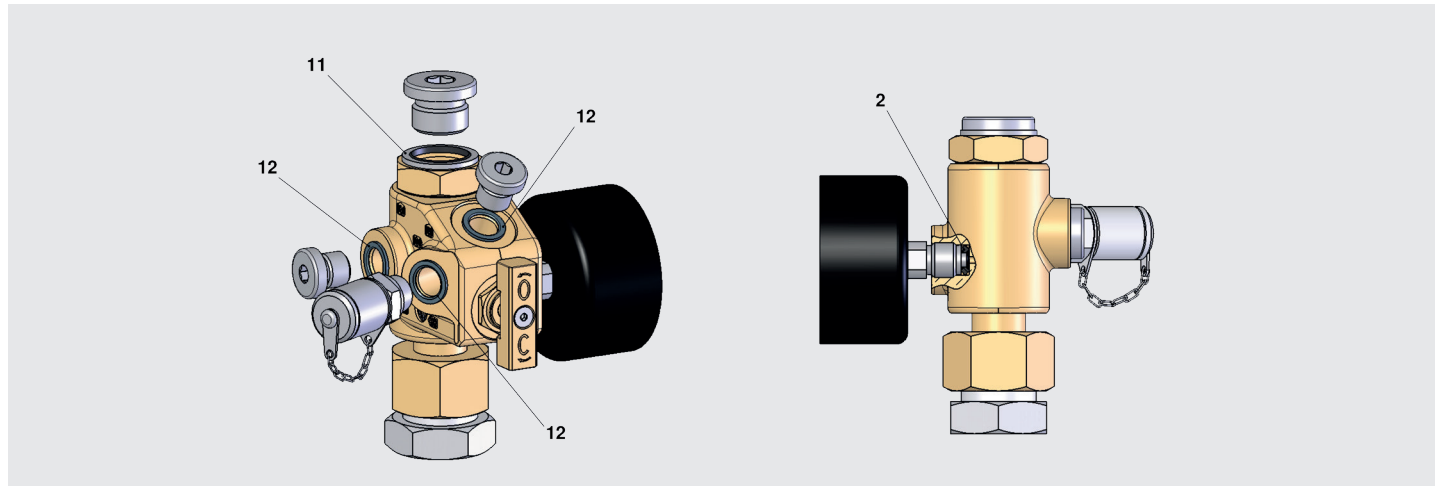

Description	Quantity	Item	Part no.
<b>Seal kit GSB450</b>	1	–	4024196
consisting of:			
Rhombic seal 1/4"	1	2	–
O-ring 15x2	1	5	–
Seal ring	1	6	–
O-ring 11x2	1	7	–
O-ring 9x2	1	8	–
O-ring 5.7x1.9	1	10	–
Seal ring	1	11	–
Seal ring	3	12	–
Pressure gauge	0 - 10 bar	3	635139
	0 - 25 bar		635140
	0 - 100 bar		635141
	0 - 250 bar		635142
	0 - 400 bar		635143

## 5.7. ACCESSORIES

### 5.7.1 Block connections and configurations

Ports	Size	Standard configuration	Optional configuration (examples)
A1	ISO 228 - G1/2	Blanking plug	GSV6 gas safety valve
A2	ISO 228 - G1/4	Blanking plug	– Burst disc – Temperature fuse
A3		Pressure gauge 0 – 400 bar	– For other measuring ranges, see section 5.5. – Special pressure gauge (please specify)
A4		Minimess valve M16x2	Minimess valve M16x1.5 (various versions possible, see section 5.5.)
A5		Blanking plug	Pressure transmitter e.g. HYDAC HDA, EDS

### Valves

Type	Description
V1	Shut-off valve
V2	Release valve (int. hex. AF 4)

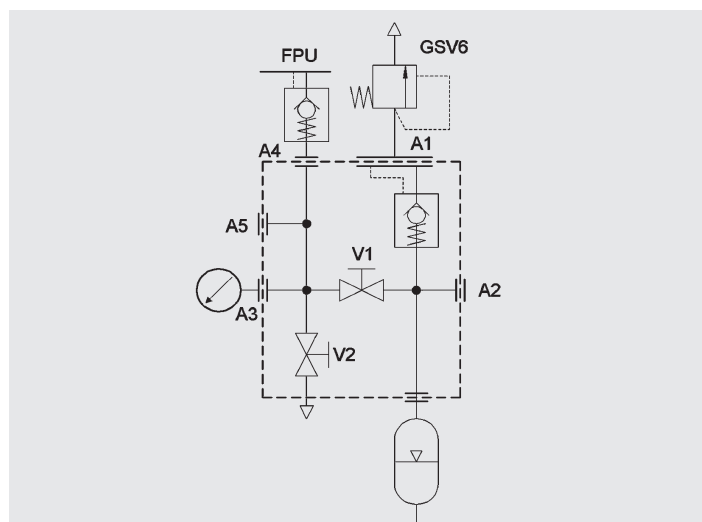

### 5.7.2 Charging hoses

HYDAC charging hoses comply with DIN EN ISO 4413 and DIN EN 853 to 857.

Charging hoses are designed for the particular maximum permitted operating pressure marked on them and 10,000 charging processes.

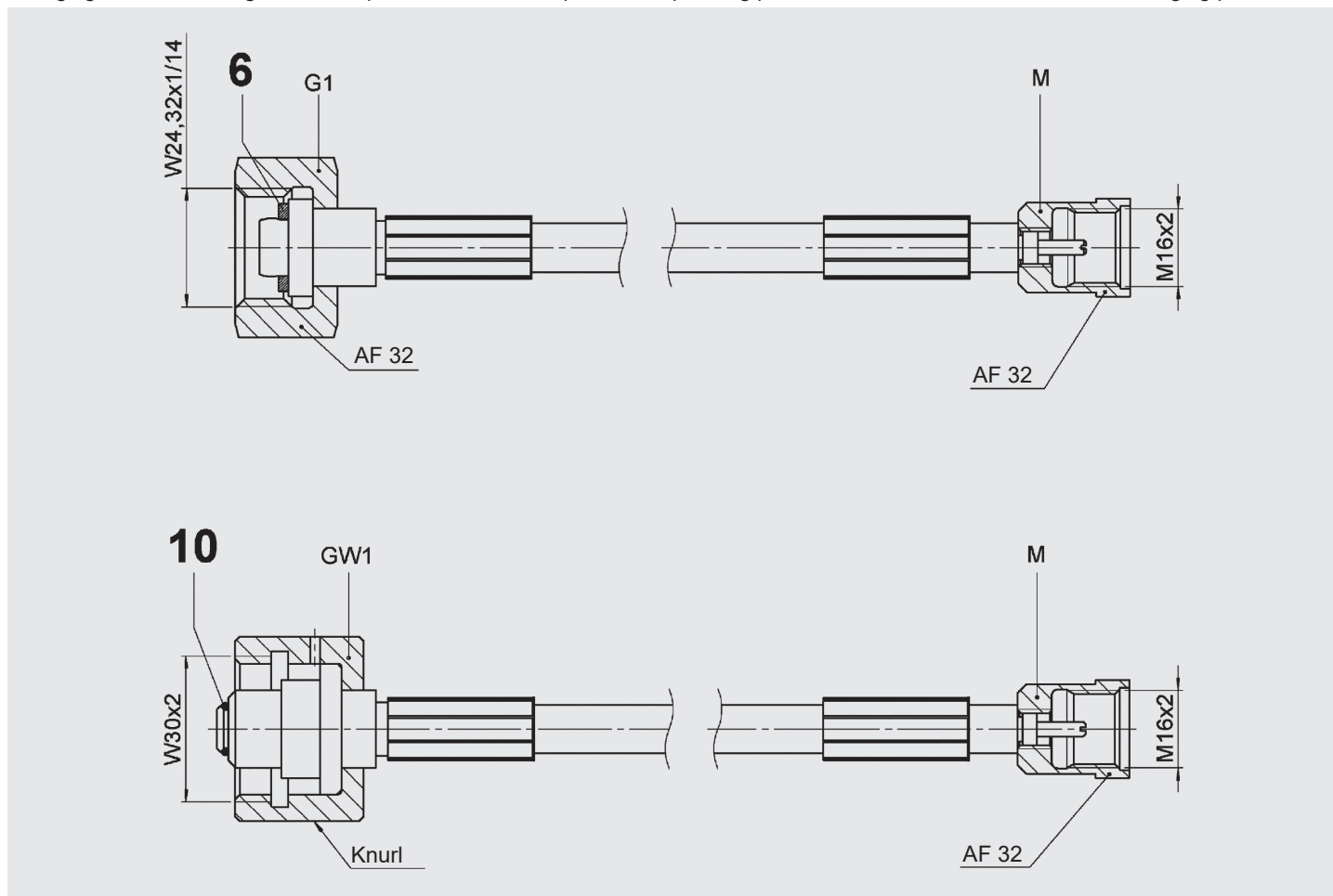

Gas connection of nitrogen bottles	Minimess connection	$p_{max}$ [bar]	Length [m]	Part no.
W30x2	M16x2	300	2.5	3434454
			4	3434457
W24.32x1/14	M16x2	200	2.5	3434424
			4	3434451
			10	3526858

Suitable adapters for foreign nitrogen bottles can be found in the following catalogue section:

- FPU charging and testing unit  
No. 3.501

## 6. NOTE

The information in this brochure relates to the operating conditions and fields of application described. For applications and/or operating conditions not described, please contact the relevant technical department. Subject to technical modifications.

**HYDAC Technology GmbH**  
Industriegebiet  
**66280 Sulzbach/Saar, Germany**  
Tel.: +49 68 97 / 509 - 01  
Internet: [www.hydac.com](http://www.hydac.com)  
E-mail: [speichertechnik@hydac.com](mailto:speichertechnik@hydac.com)