

Safety and shut-off block SAF/DSV

1. DESCRIPTION

1.1. FUNCTION

The HYDAC safety and shut-off block is a hydraulic accessory element that is used to protect against excess pressure on the fluid side and to shut-off and relieve hydraulic accumulators.

It takes into account the applicable safety regulations according to DIN EN ISO 4413 and the German Industrial Safety Regulation (BetrSichV).

The HYDAC pressure relief valve (DB12) is used in the SAF series. It is a direct-acting pressure relief valve in a poppet valve construction with excellent opening and closing characteristics. This version of the DB12 complies with the requirements of the European Pressure Equipment Directive (PED) with CE marking and is supplied with a declaration of conformity and operating instructions.

The operating instructions must be observed!

No. 5.169.B

Product advantages

The compact combination of components considerably simplifies the connection of a consumer to the hydraulic system and provides the following benefits:

- Minimum of space, maintenance and piping required. Up to 10 fewer pipe fittings are necessary compared to individual piping.
- Considerable reduction in installation time.
- Connections for various accumulator designs and manufacturers are available – all imperial and metric thread types as well as manifold-mounted and weld nipple connections.
- Additional valves such as pilot-operated check valves, flow control valves and combined flow control and check valves can be fitted to system connection P.

1.2. DESIGN

The SAF safety and shut-off block consists of a valve block, an integrated HYDAC pressure relief valve, a main shut-off valve and a manually operated pressure release valve. The necessary pressure gauge connections are provided in addition to the tank connection.

In addition, an optional solenoid-operated 2-way directional valve allows automatic discharge of the accumulator or consumer and therefore of the hydraulic system in an emergency or for shut-down.

1.2.1 Circuit diagram

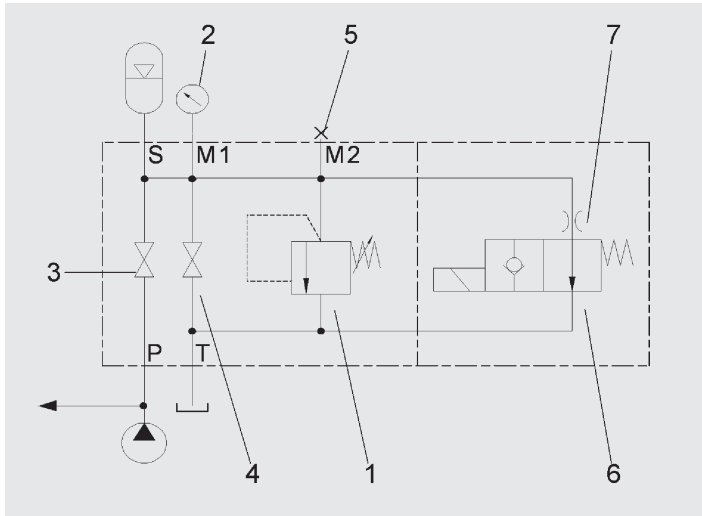

- 1 DB12 pressure relief valve, see brochure:
 - DB12120A-01X-CE
 - No. 5.169
- 2 M1 connection (optional pressure gauge available)
ISO 228 - G 1/4 (SAF10, SAF8)
ISO 228 - G 1/2 (all others)
- 3 Shut-off valve
- 4 Pressure release valve
- 5 M2 connection (e.g. for p₀-Guard)
ISO 228 - G 1/4 (all sizes)

These devices are combined in a compact, space-saving HYDAC safety and shut-off block. The following devices are also available:

- 6 Solenoid-operated release valve (optional for type E)
- 7 Throttle
- S Hydraulic accumulator connection
- P Pump connection
- T Tank connection

1.2.2 Connections

The safety and shut-off block has the following connections:

- S – Hydraulic accumulator connection
- P – Pump connection
Connection of the SAF to the system
- T – Tank connection
The piping leading to the tank must be installed separately. This ensures that the flow can be channelled away to the tank unpressurised when the DB12 pressure relief valve is opened.
- M1 – With optional pressure gauge
ISO 228 – G 1/4 (SAF10, SAF8)
ISO 228 – G 1/2 (all others)
- M2 – e.g. for p₀-Guard
ISO 228 – G 1/4 (all sizes)

1.3. SPECIFICATIONS

1.3.1 Operating fluids

Mineral oil to DIN 51524
Part 1 and Part 2
(other fluids on request)

Viscosity range

min. 10 mm²/s
max. 380 mm²/s

Filtration

Max. permitted contamination level of the operating fluid to ISO 4406 Class 21/19/16 or SAE AS 4059 Class 11.
We recommend a filter with a minimum retention rate of $\beta_{20} \geq 100$.
The fitting of filters and regular replacement of the filters guarantees correct operation, reduces wear and extends the service life.

1.3.2 Permitted operating temperature

Standard design
-10 °C ... +80 °C
(ambient temperature for E type limited to
-10 °C ... +60 °C)

Low-temperature version
-40 °C ... +80 °C

1.3.3 Max. operating pressure

400 bar

1.3.4 Model with solenoid-operated pressure release

Solenoid-operated by means of pressure-tight, oil-immersed, single-stroke solenoids in accordance with VDE 0580. Actuating solenoid with male connector to DIN 43650, standard for general industrial applications, available for 24 V DC and 230 V AC.

Type of voltage

DC solenoid

When connected to AC voltage, the necessary DC voltage is produced by means of a bridge rectifier connector.

Voltage tolerance

± 15 % of the nominal voltage

Nominal current

Dependent on the nominal voltage

24 V DC 0.80 A

230 V AC 0.11 A

Power consumption

p₂₀ = 18 W

Duty cycle

100 % DC = CO (continuous operation)

Switching time

This depends on the symbol, pressure at the individual connections and the flow rate

WSM06020Y:

on: 50 ms

off: 35 ms

WSM06020Z:

on: 35 ms

off: 50 ms

1.3.5 Notice

All work with HYDAC safety and shut-off blocks must only be carried out by suitably trained staff.

Incorrect installation or handling can lead to serious accidents.

The operating instructions must be observed!

No. 3.551.BA

Relevant PDF documents are available from our Download Center at www.hydac.com.

1.4. STANDARD DESIGNS

1.4.1 Manual pressure release via pressure release valve (model M)

The basic version of the safety and shut-off block is equipped with a direct-acting relief valve and a manually operated pressure release valve for manual pressure release.

Sizes: SAF10, SAF20, SAF32

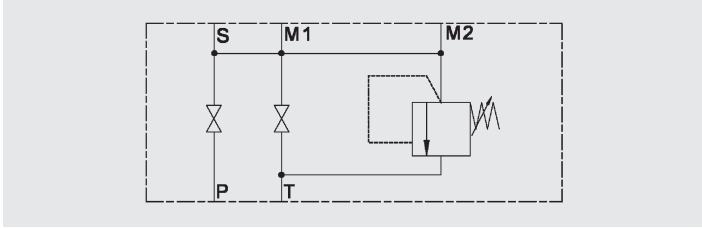

1.4.2 Solenoid pressure release (E type)

The E type safety and shut-off block has a solenoid-operated 2-way directional valve for automatic pressure release of the accumulator and the hydraulic system.

Sizes: SAF10, SAF20, SAF32

Normally open "Y"

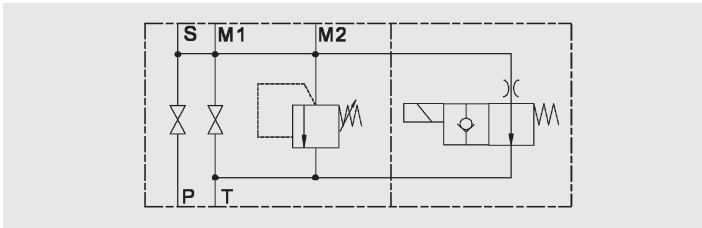

Normally closed "Z"

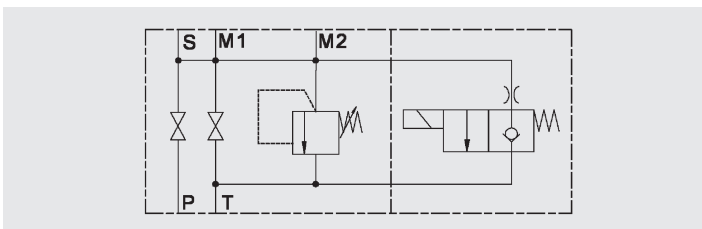

1.5. ΔP-Q GRAPHS FOR SAF

Measured at:

$v = 32 \text{ mm}^2/\text{s}$

$t_{\text{oil}} = 40 \text{ }^\circ\text{C}$

Operating pressure = 400 bar

1.5.1 Flow from the pump to the accumulator SAF10M/E

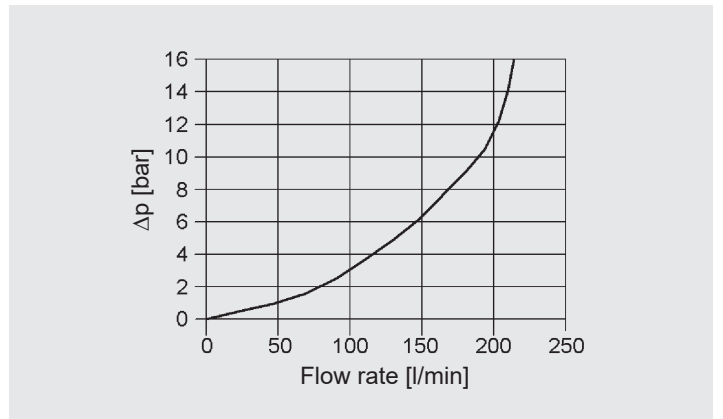

SAF20M/E

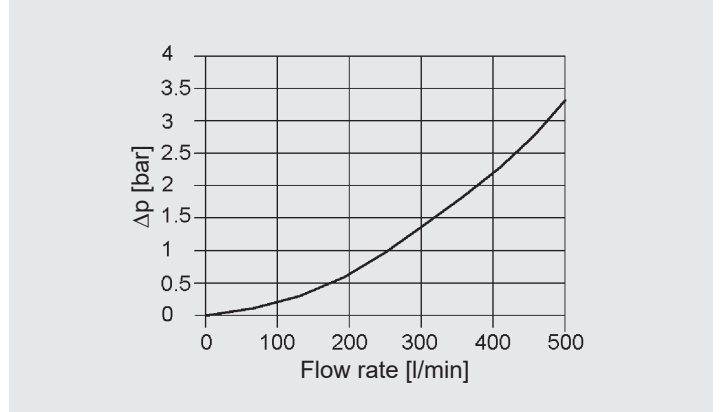

SAF32M/E; SAF32-3M/E

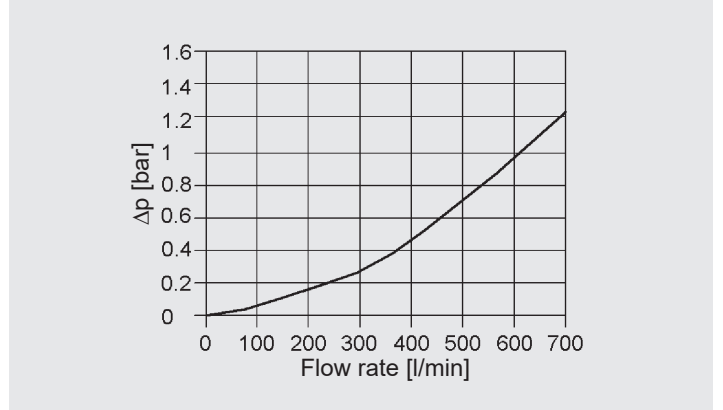

1.5.2 Flow from the accumulator via the solenoid-operated pressure release valve to the tank
SAF10E

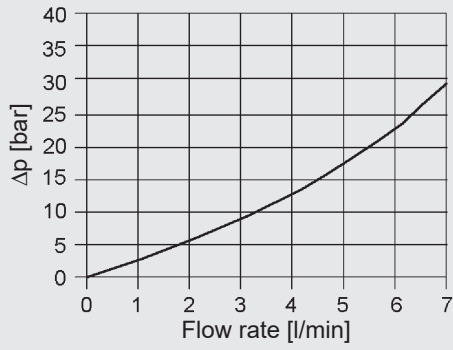

SAF20E

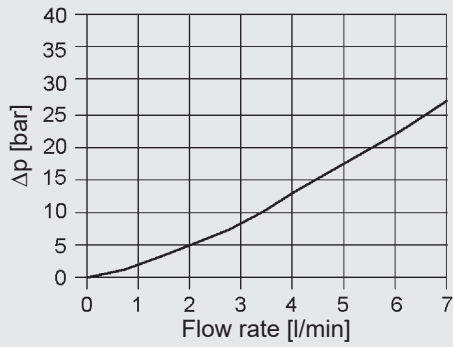

SAF32E; SAF32-3E

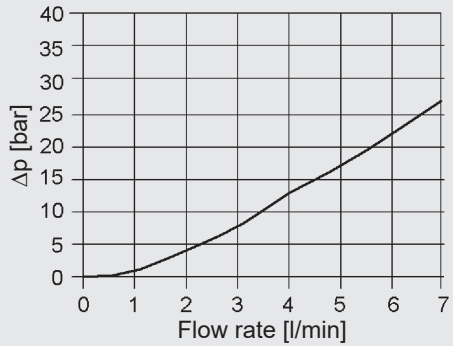

1.5.3 Flow from the accumulator via the pressure release valve to the tank
SAF10M/E

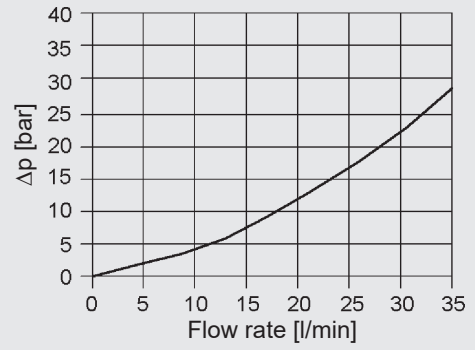

SAF20M/E

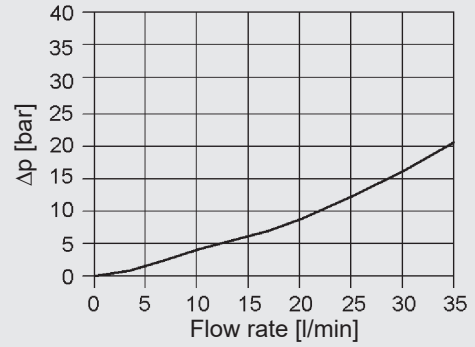

SAF32M/E; SAF32-3M/E

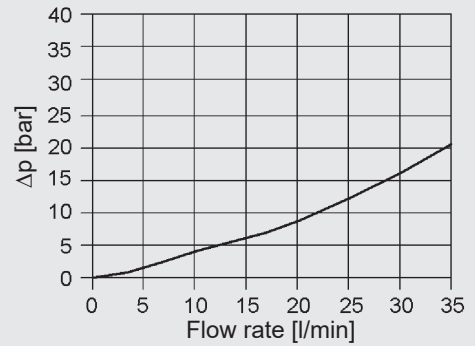

2. MODEL CODE FOR SAF

Not all combinations are possible. Order example.
For further information, please contact HYDAC.

SAF 20 E 1 2 Y 1 T 210 A - S 13 - LPI - A9

Safety and shut-off block

Series SAF

Nominal size of main shut-off valve

- 8 = DN8
- 10 = DN10
- 20 = DN20
- 32 = DN32
- 32-3 = DN32 with 3 size 12 pressure release valves
- 50 = DN50

Type

- M = manual discharge
- E = solenoid-operated and manual discharge

Block material ¹⁾

- 1 = carbon steel
- 3 = stainless steel
- 6 = carbon steel (low temperature)

Seal material (elastomer)

- 2 = NBR
- 5 = EPDM ⁶⁾
- 6 = FKM
- 7 = other

Type – poppet valve ⁴⁾

- Y = normally open (2/2 directional valve WSM06020Y)
- Z = normally closed (2/2 directional valve WSM06020Z, only up to 350 bar)

Voltage type – poppet valve ⁴⁾

- 1 = 24 V DC (standard)
- 2 = 115 V AC
- 3 = 230 V AC
- 7 = other

Pressure relief valve

- T = pressure setting with TÜV
- N = pressure setting without TÜV ⁶⁾

Pressure setting

e.g. 210 bar

Standard threaded connection

- A = ISO 228 (BSP) ³⁾
- B = DIN 13, to ISO 965/1 (metric) ²⁾
- C = ANSI B1.1 (UNF, O-ring seal to SAE) ²⁾

Adapter

to accumulator (see section 8.)
e.g. S13 = ISO 228 – G 2A

Additional equipment (see section 4.)

- L = lockable main shut-off valve (locking device)
- LPI = model L with additional position monitoring (inductive proximity switch)
- LPM = model L with additional position monitoring (mechanical limit switch with roller lever)
- LS = lockable pressure release valve

Certification code DB12 ⁵⁾

No details = European Pressure Equipment Directive (PED)
A6 = Russia, and others
A9 = China

Accessories – please give full details when ordering, see section 6.

¹⁾ Dependent on type and pressure rating

²⁾ On request

³⁾ In conjunction with SAF8 = 9/16-18UNF or ISO 228 - G 1/4 (BSP)

⁴⁾ Only for type E

⁵⁾ For further information, see catalogue section Accumulator Technology, No. 3.000, section 4.

⁶⁾ Only with pressure relief valve N

3. STANDARD ITEMS

Part no. ¹⁾	Product designation	Nominal size	Type ²⁾	Pressure rating	Adapter
2121346	SAF10M12T210A	10	M	210	-
2121403	SAF10M12T210A-S12				S12
2121419	SAF10M12T210A-S13				S13
2121236	SAF10M12T330A			330	-
2121443	SAF10M12T330A-S12				S12
2121444	SAF10M12T330A-S13				S13
2121662	SAF10E12Y1T210A	10	E	210	-
2125975	SAF10E12Y1T210A-S12				S12
2126796	SAF10E12Y1T210A-S13				S13
2122211	SAF10E12Y1T330A			330	-
2121949	SAF10E12Y1T330A-S12				S12
2122050	SAF10E12Y1T330A-S13				S13
2120319	SAF20M12T210A	20	M	210	-
2120455	SAF20M12T210A-S12				S12
2120376	SAF20M12T210A-S13				S13
2120323	SAF20M12T330A			330	-
2120522	SAF20M12T330A-S12				S12
2120457	SAF20M12T330A-S13				S13
2120320	SAF20E12Y1T210A	20	E	210	-
2121895	SAF20E12Y1T210A-S12				S12
2120380	SAF20E12Y1T210A-S13				S13
2120394	SAF20E12Y1T330A			330	-
2120879	SAF20E12Y1T330A-S12				S12
2120383	SAF20E12Y1T330A-S13				S13
2120321	SAF32M12T210A	32	M	210	-
2120377	SAF32M12T210A-S309				S309
2122231	SAF32M12T330A			330	-
2120375	SAF32M12T330A-S309				S309
2120318	SAF32E12Y1T210A	32	E	210	-
2120448	SAF32E12Y1T210A-S309				S309
2120371	SAF32E12Y1T330A			330	-
2120379	SAF32E12Y1T330A-S309				S309

¹⁾ Preferred models

²⁾ Type E: Poppet valve, normally open (Y)

3.1. TABLES AND DRAWINGS

3.1.1 SAF10

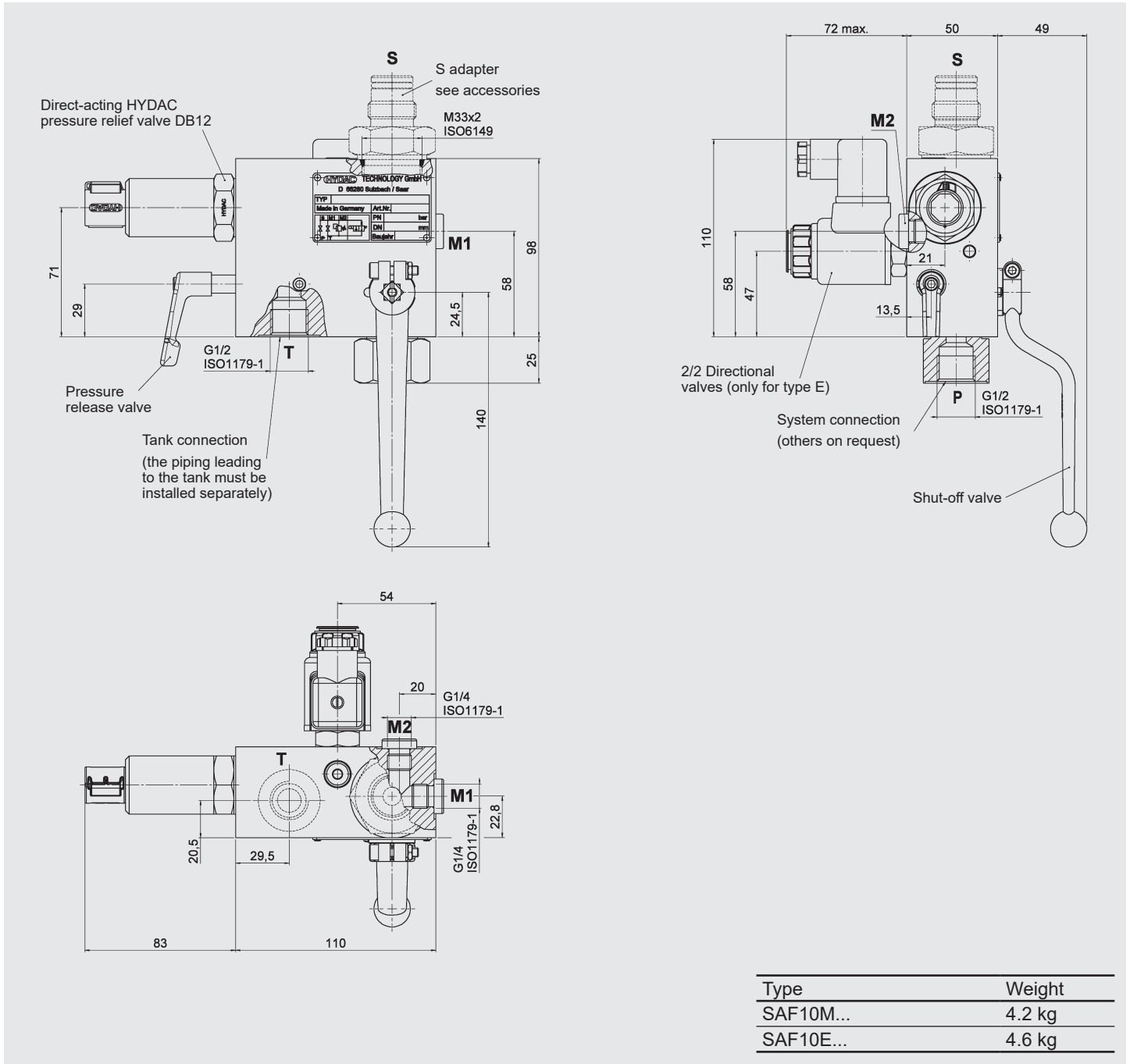

Other SAF10

Type	Part no.	Type	Part no.
SAF10M12T400A	2121582	SAF10E12Y1T400A	2125858
SAF10M12T350A	2122208	SAF10E12Y1T350A	2122210
SAF10M12T315A	2121121	SAF10E12Y1T315A	2122212
SAF10M12T300A	2121354	SAF10E12Y1T300A	2122213
SAF10M12T250A	2121353	SAF10E12Y1T250A	2122214
SAF10M12T200A	2121351	SAF10E12Y1T200A	2122215
SAF10M12T150A	2121345	SAF10E12Y1T150A	2122216
SAF10M12T100A	2121344	SAF10E12Y1T100A	2122041
SAF10M12T070A	2121350	SAF10E12Y1T070A	2122217
SAF10M12T050A	2122207	SAF10E12Y1T050A	2122218
SAF10M12T035A	2121349	SAF10E12Y1T035A	2122219

3.1.2 SAF20

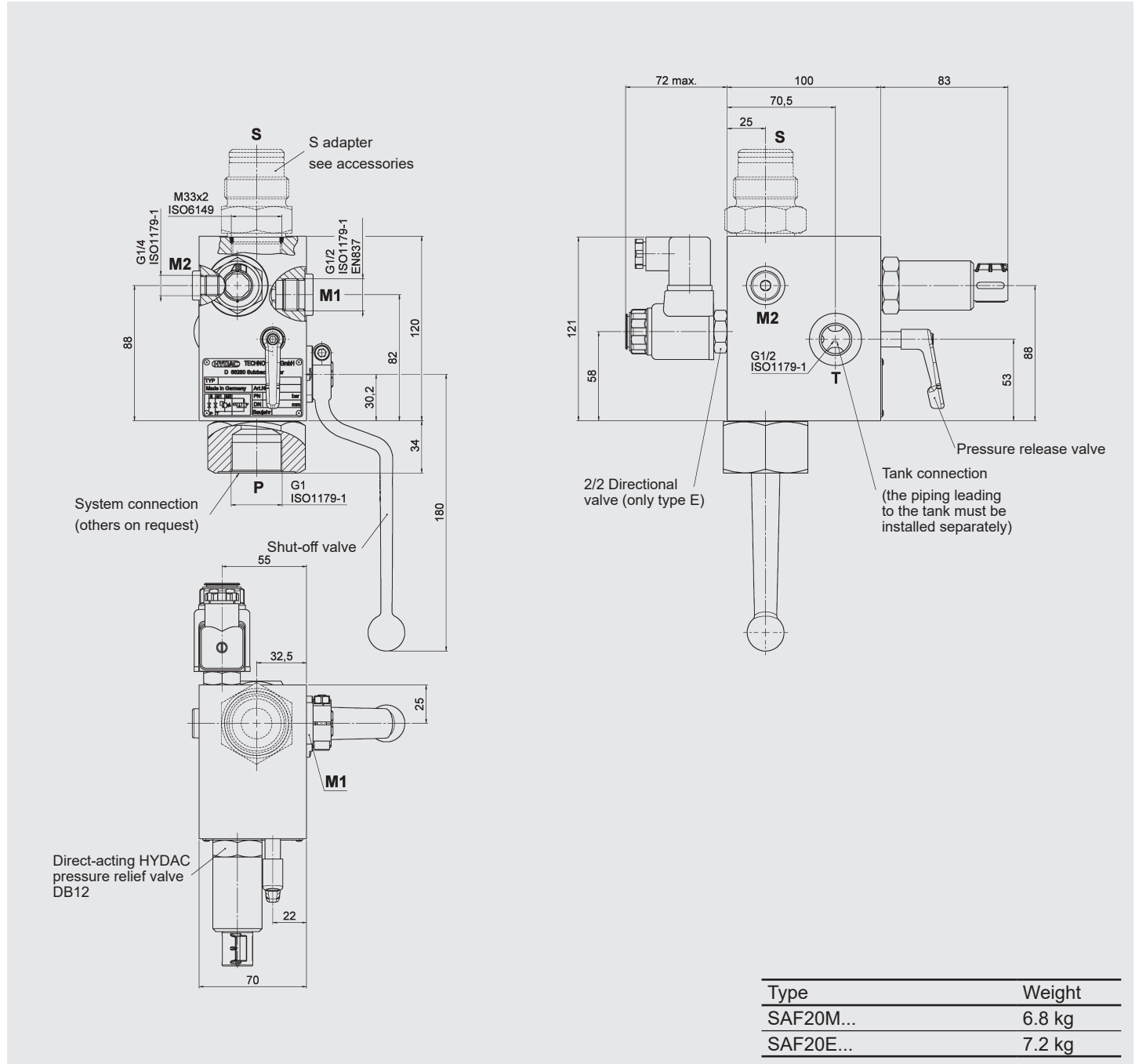

Other SAF20

Type	Part no.	Type	Part no.
SAF20M12T400A	2120317	SAF20E12Y1T400A	2121022
SAF20M12T350A	2120434	SAF20E12Y1T350A	2121979
SAF20M12T315A	2120324	SAF20E12Y1T315A	2120833
SAF20M12T300A	2120332	SAF20E12Y1T300A	2120836
SAF20M12T250A	2120432	SAF20E12Y1T250A	2120851
SAF20M12T200A	2120325	SAF20E12Y1T200A	2120835
SAF20M12T150A	2120330	SAF20E12Y1T150A	2120832
SAF20M12T100A	2120401	SAF20E12Y1T100A	2120369
SAF20M12T070A	2120326	SAF20E12Y1T070A	2120849
SAF20M12T050A	2122172	SAF20E12Y1T050A	2121000
SAF20M12T035A	2120281	SAF20E12Y1T035A	2122220

3.1.3 SAF32

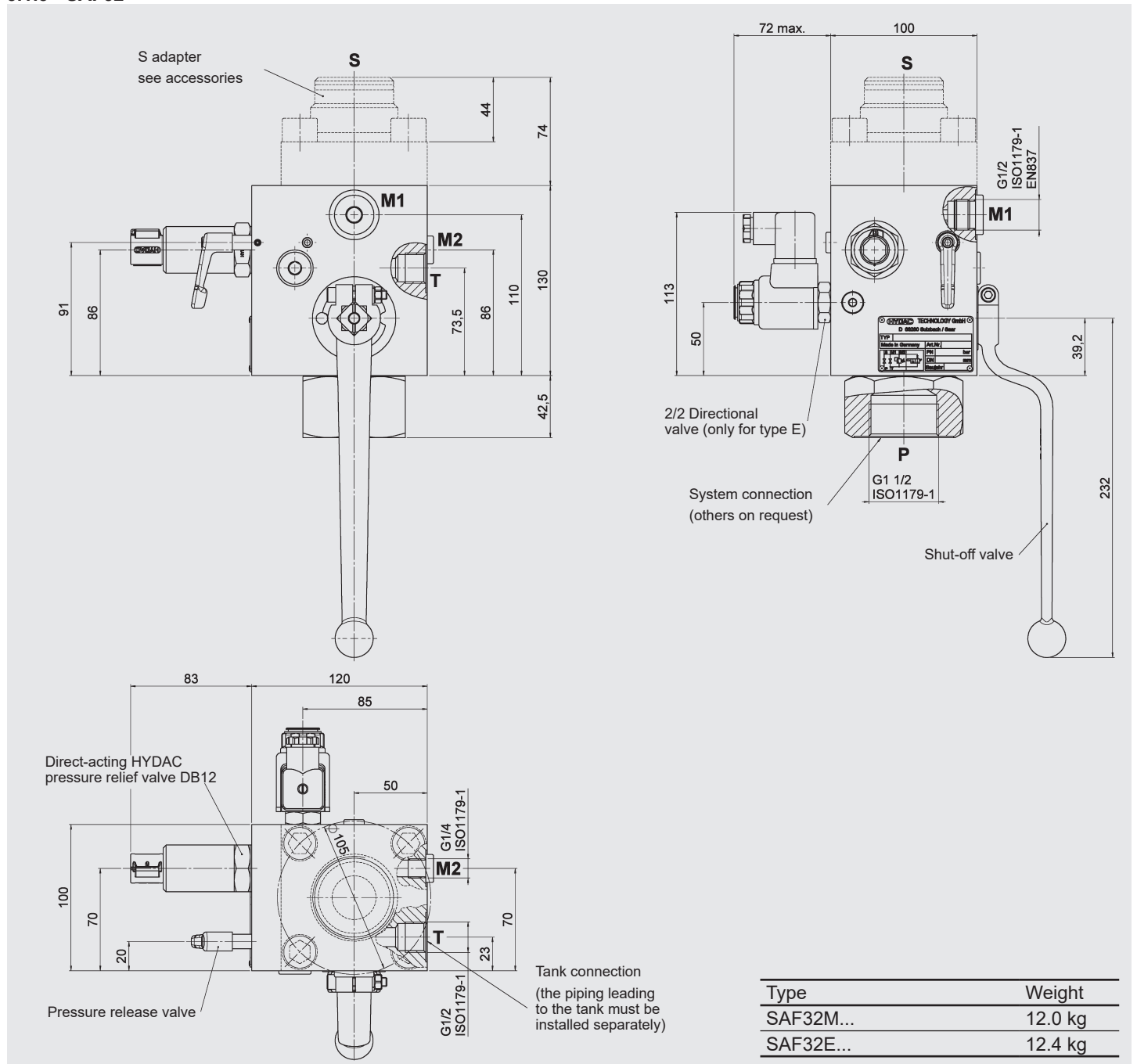

Type	Weight
SAF32M...	12.0 kg
SAF32E...	12.4 kg

Other SAF32

Type	Part no.	Type	Part no.
SAF32M12T400A	2125856	SAF32E12Y1T400A	2123123
SAF32M12T350A	2122230	SAF32E12Y1T350A	3125142
SAF32M12T315A	2121136	SAF32E12Y1T315A	2122222
SAF32M12T300A	2120837	SAF32E12Y1T300A	2120834
SAF32M12T250A	2122233	SAF32E12Y1T250A	2122223
SAF32M12T200A	2121135	SAF32E12Y1T200A	2122224
SAF32M12T150A	2121134	SAF32E12Y1T150A	2122225
SAF32M12T100A	2121129	SAF32E12Y1T100A	2122226
SAF32M12T070A	2122234	SAF32E12Y1T070A	2122227
SAF32M12T050A	2121137	SAF32E12Y1T050A	2122228
SAF32M12T035A	2121125	SAF32E12Y1T035A	2122229

3.2. SPARE PARTS

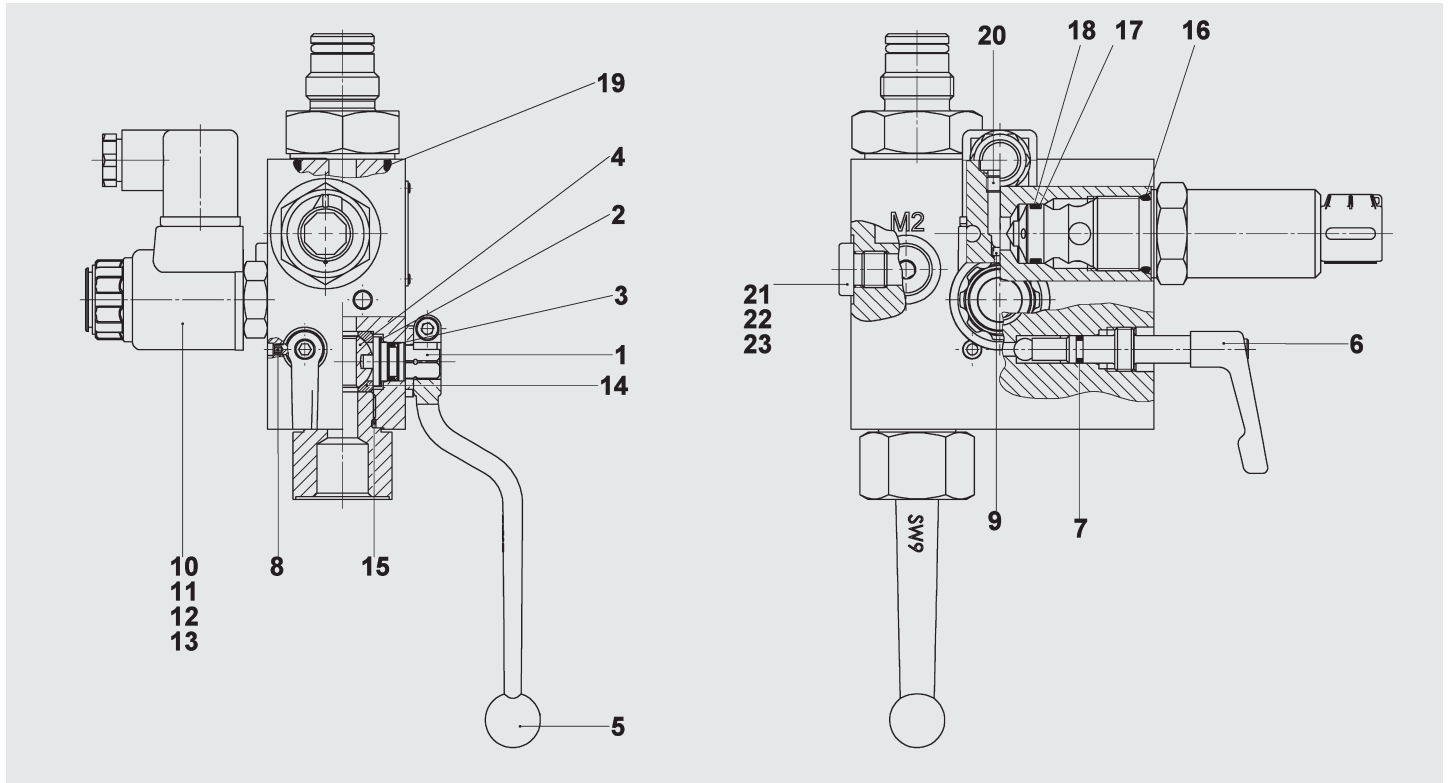

Type of safety and shut-off block	SAF10M, SAF10E	SAF20M, SAF20E	SAF32M, SAF32E
Description	Item	Dimensions or part no.	
Repair kit consisting of:	2122238 (NBR) 2122240 (FKM)	2122242 (NBR) 2122244 (FKM)	2122246 (NBR) 2122248 (FKM)
Spindle	1		
Disc	2		
O-ring	3	10x2	20x3
Ball	4		
Switching handle	5		
Spindle (incl. ball)	6		
O-ring	7	6x2	
Threaded pin	8	M4x6	M4x10
Orifice	9	Ø1.5 mm ($Q_{max} - 25.5$ l/min)	
O-ring	11	17x2	
Support ring	12	11.7x15x1	
O-ring	13	11x2	
Sealing cup	14		
O-ring	15	21x2	56.7x2.8
O-ring	16	23.47x2.62	
Support ring	17	18.3x21.5x1	
O-ring	18	18x2	
O-ring	19	29.7x2.8	37.2x3
Locking screw	20	G 1/8	G 1/8
	21	G 1/4	G 1/4
	22	–	G 3/8
	23	–	G 1/2
2/2 directional valve assembly (only for E type, voltage 24 V DC)	10	WSM06020Y – normally open WSM06020Z – normally closed	3153871 (350 bar); 3153874 (350 bar); 3156869 (400 bar); 3156873 (400 bar)
Locking screw assembly (converts "E" type to "M" type)		277645	
Seal kit consisting of: No. 3, 7, 8, 11, 12, 13, 14, 15, 16, 17, 18, 19, 20, 21, 22, 23		2121699 (NBR) 2121701 (FKM)	2121703 (NBR) 2121705 (FKM)
Spindle repair kit consisting of: No. 6, 7, 8		2115648 (NBR) 2115649 (FKM)	2121707 (NBR) 2121709 (FKM)

4. ADDITIONAL EQUIPMENT FOR SAFETY AND SHUT-OFF BLOCKS

In safety and shut-off blocks, the position of the shut-off valve/the pressure release valve can be secured. HYDAC supplies various additional devices for this (retrofit options, see section 8.):

Additional device L

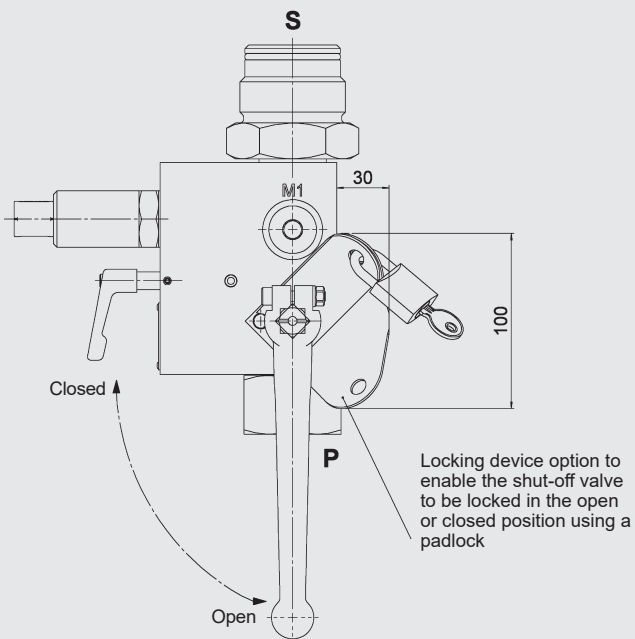

Locking device option to enable the shut-off valve to be locked in the open or closed position using a padlock

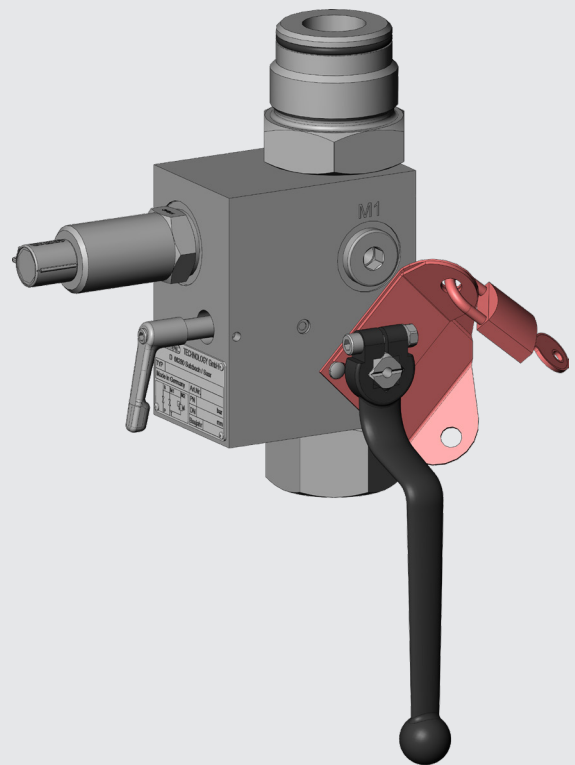

Additional device LPI

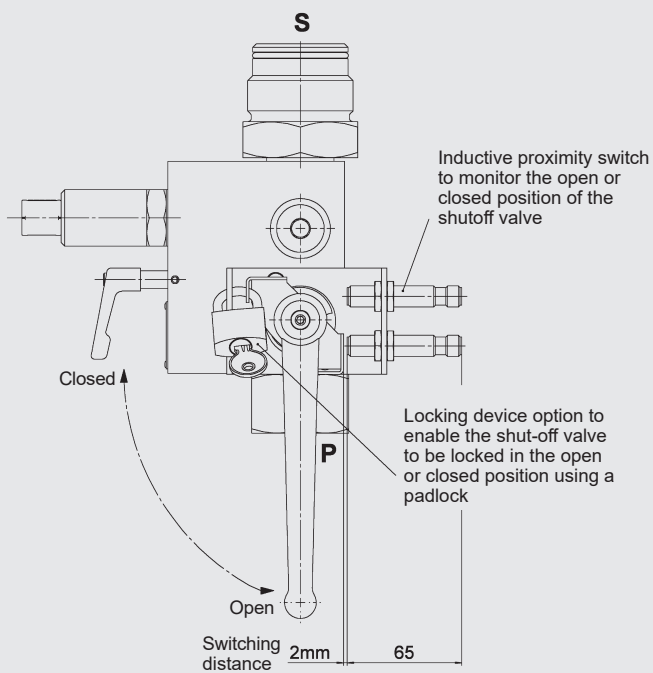

Inductive proximity switch to monitor the open or closed position of the shutoff valve

Locking device option to enable the shut-off valve to be locked in the open or closed position using a padlock

Switching distance 2mm

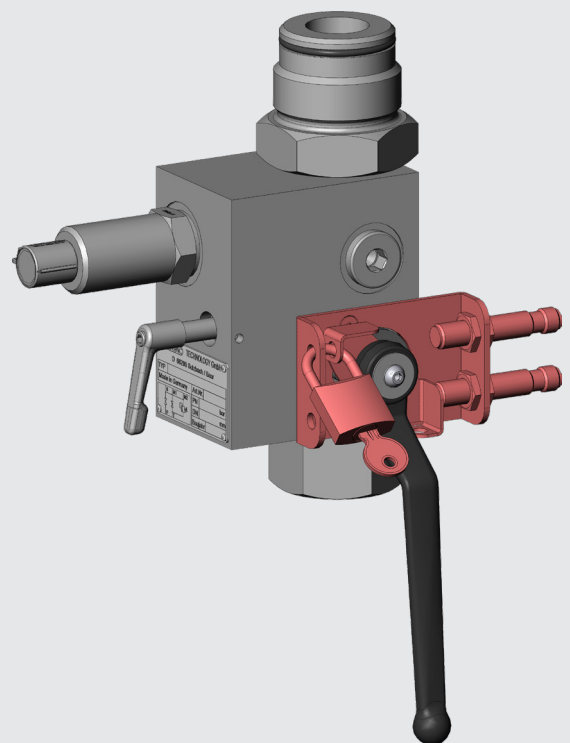

Additional device LPM

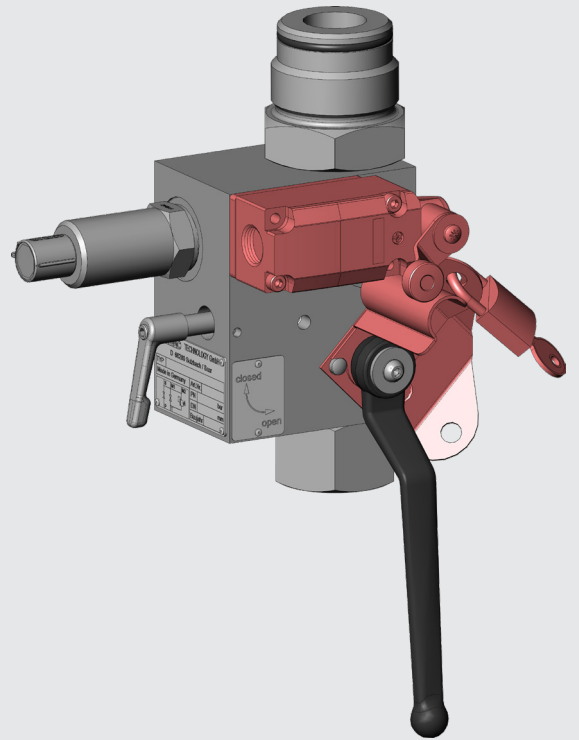
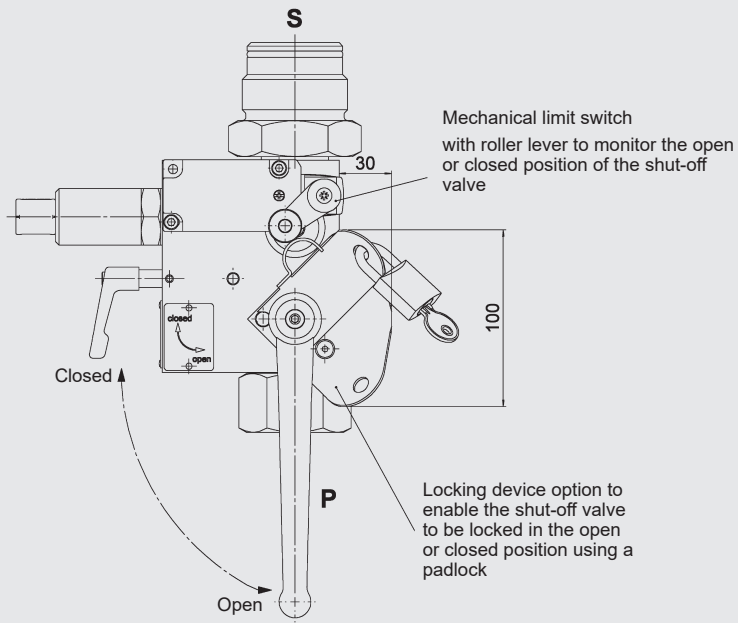

Additional device LS

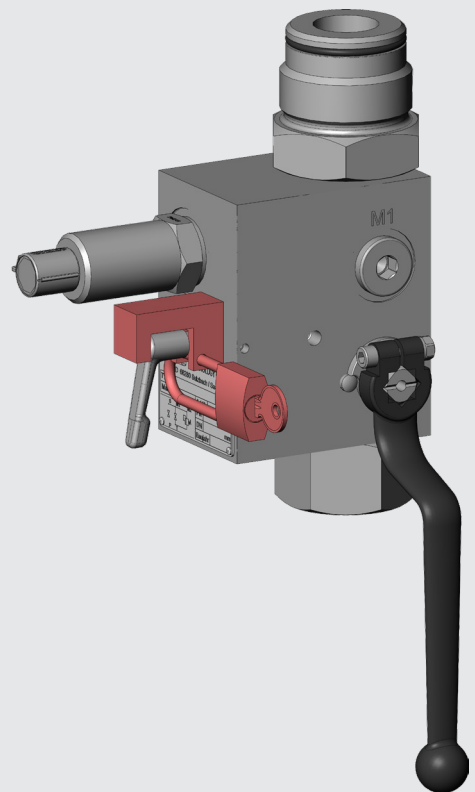
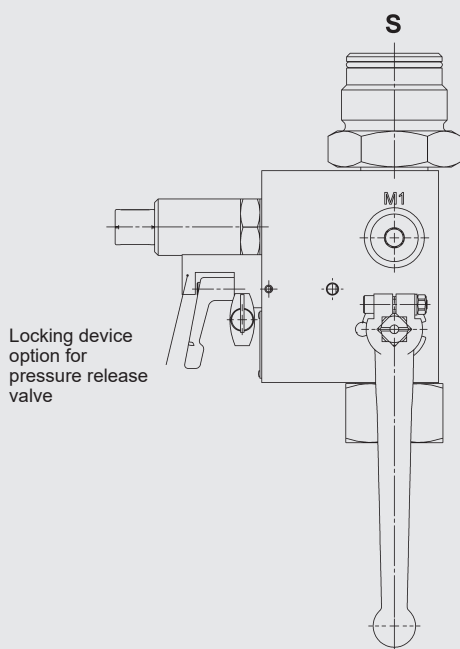

5. SPECIAL MODELS

5.1. SAF32-3M(E)

with 3 direct acting pressure relief valves DB12
(max. operating pressure 400 bar)

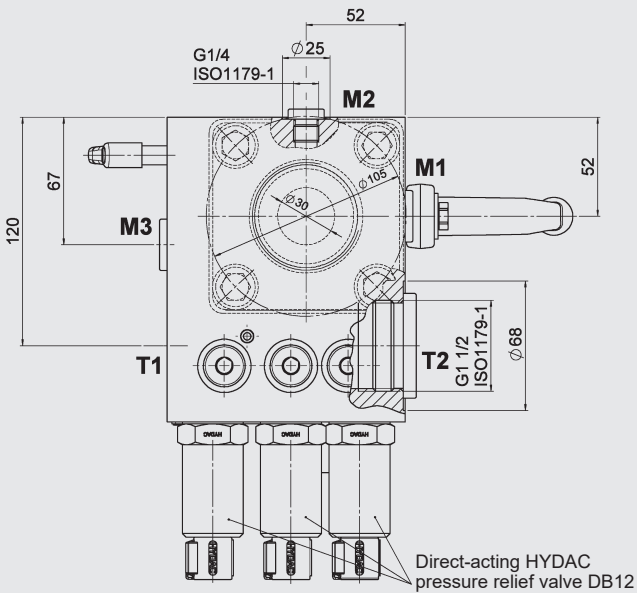
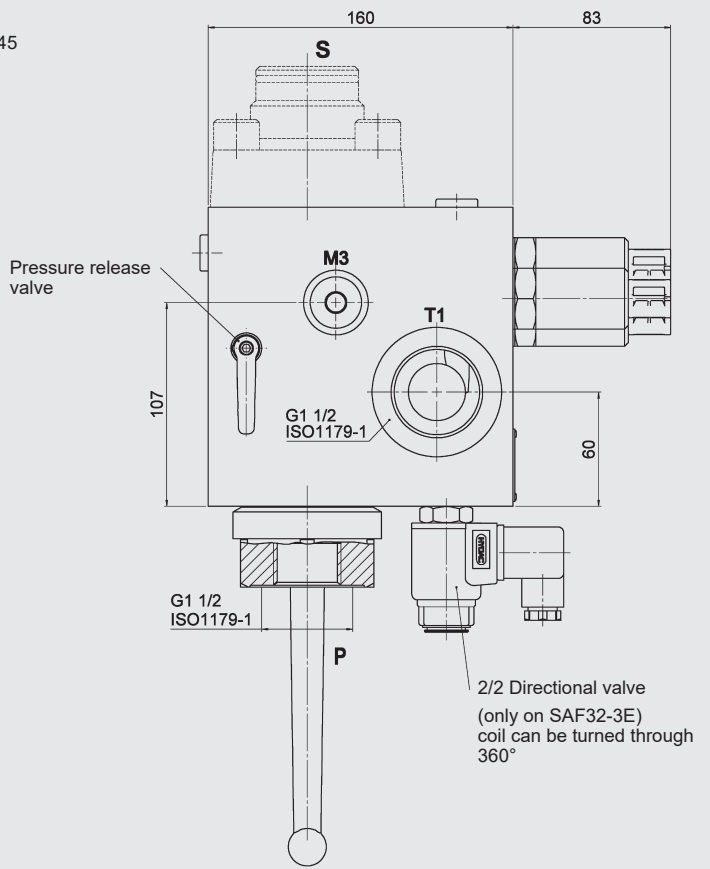
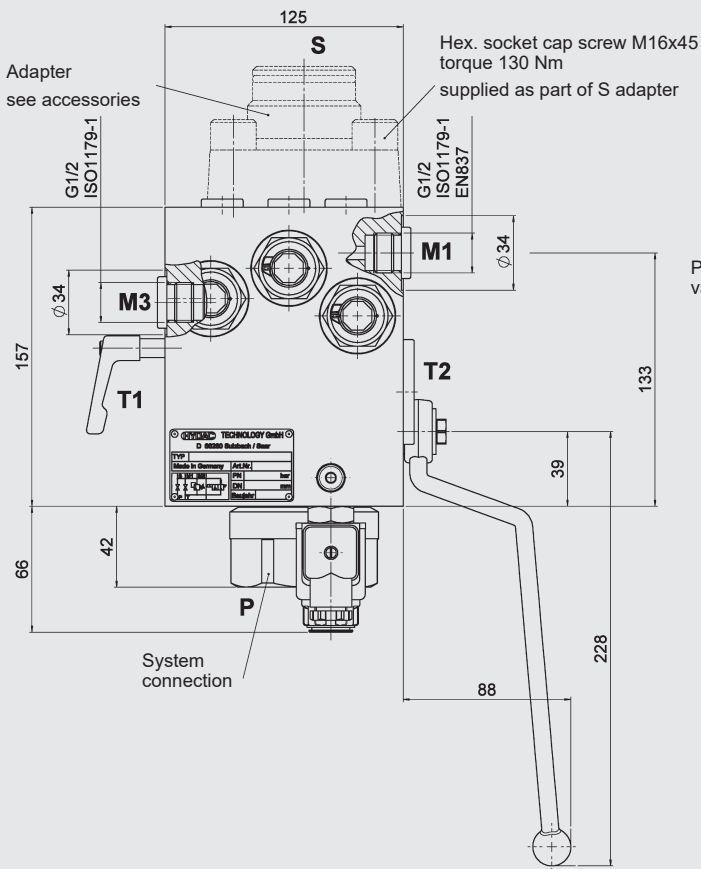

SAF32-3M

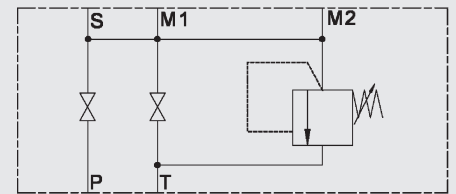

SAF32-3E

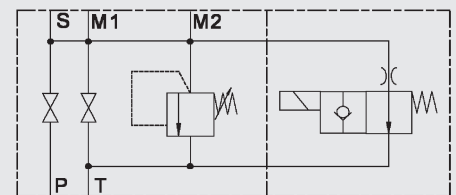

Type	Weight
SAF32-3M...	24 kg
SAF32-3E...	25 kg

5.2. SAF50M(E)

for high flow rates
with 3 direct-acting pressure relief valves DB12

Max. operating pressure

Type M: 400 bar

Type E: 350 bar

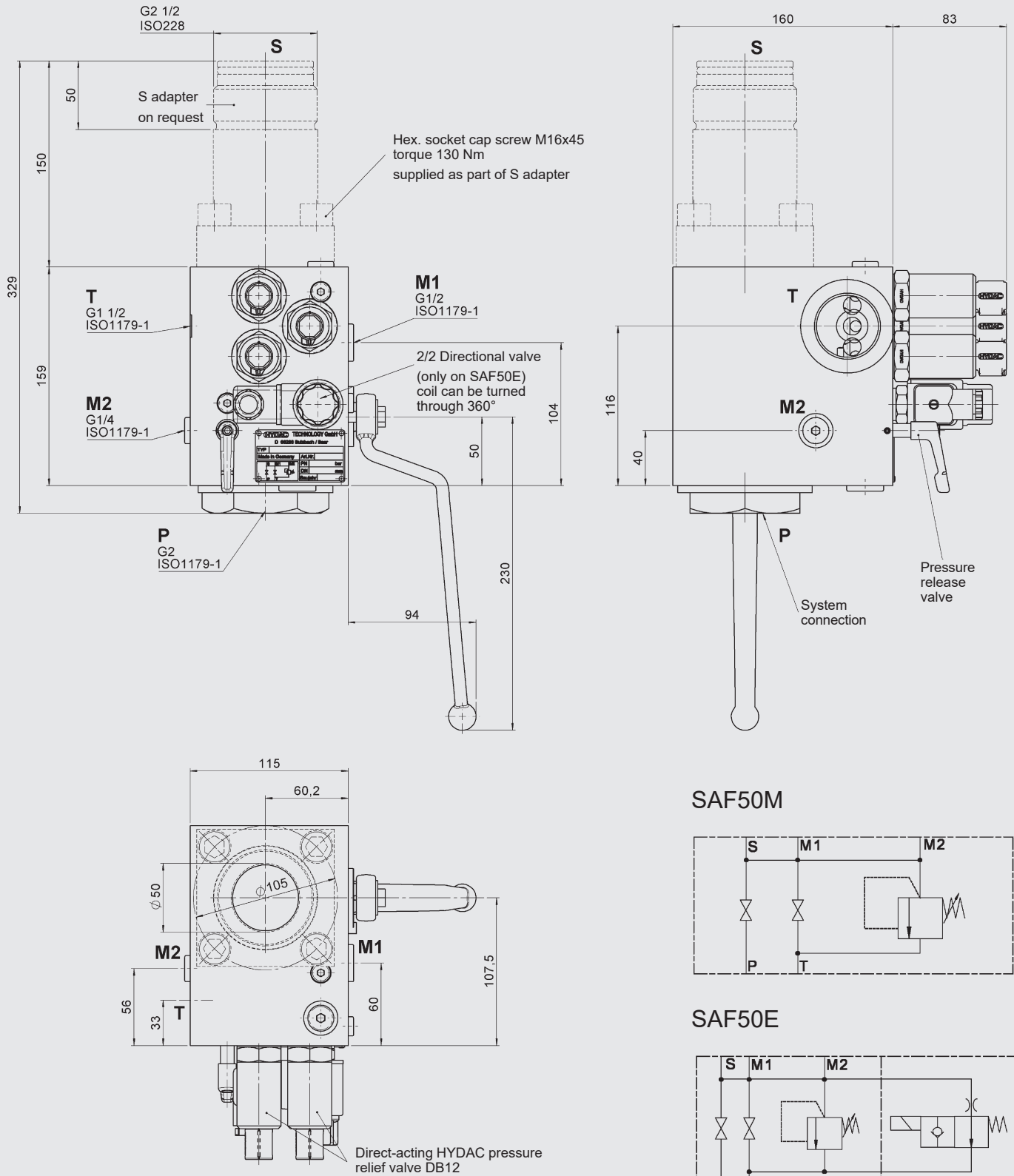

SAF50M

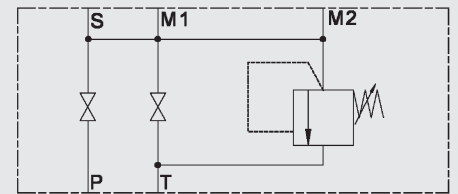

SAF50E

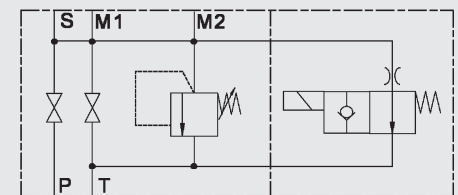

Type	Weight
SAF50M...	25 kg
SAF50E...	26 kg

5.3. SA32M(E)29

with pilot-operated pressure relief valve ($Q_{max} = 600 \text{ l/min}$)
(max. operating pressure 330 bar)

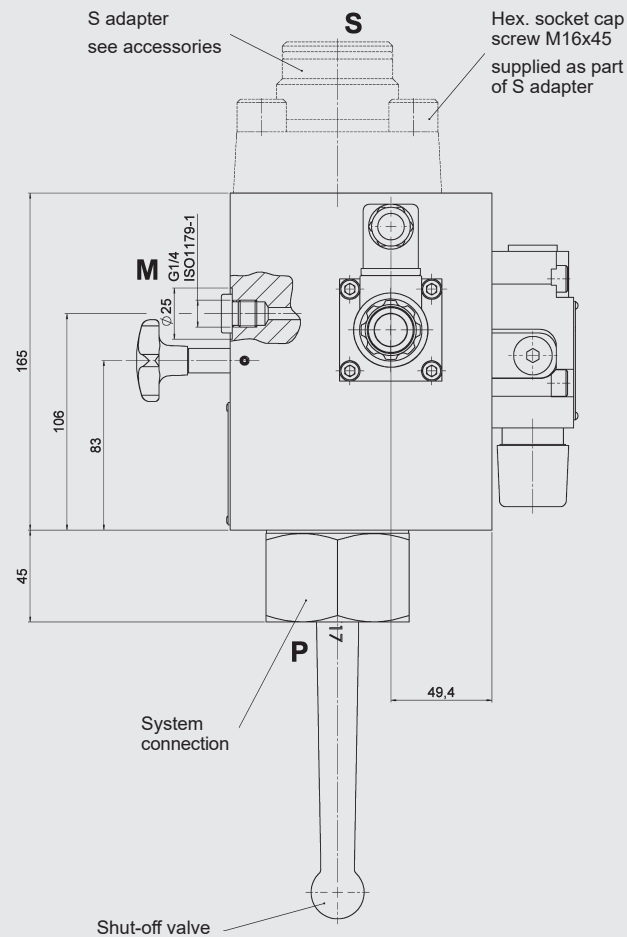
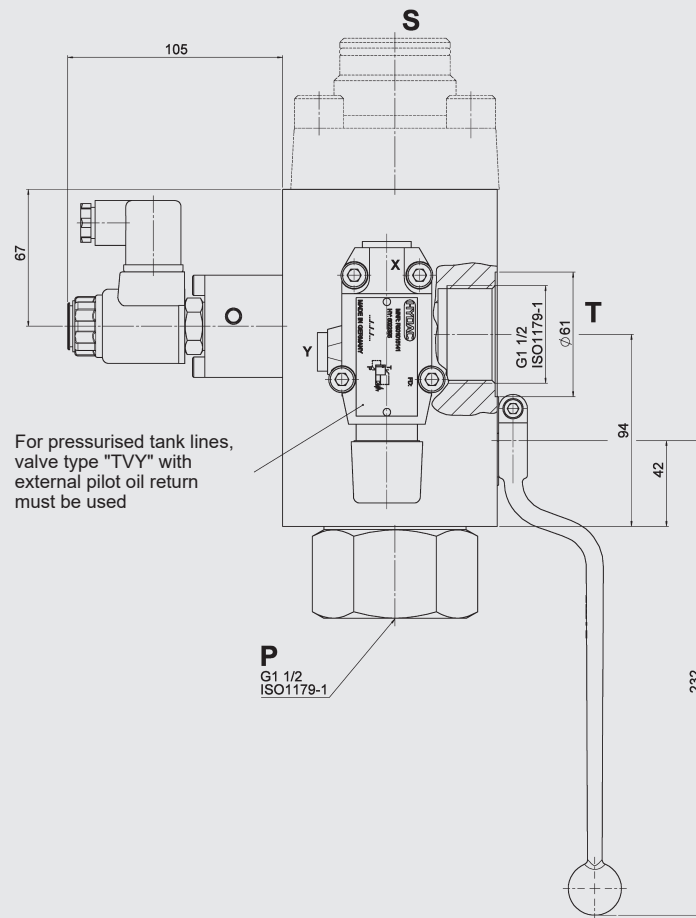

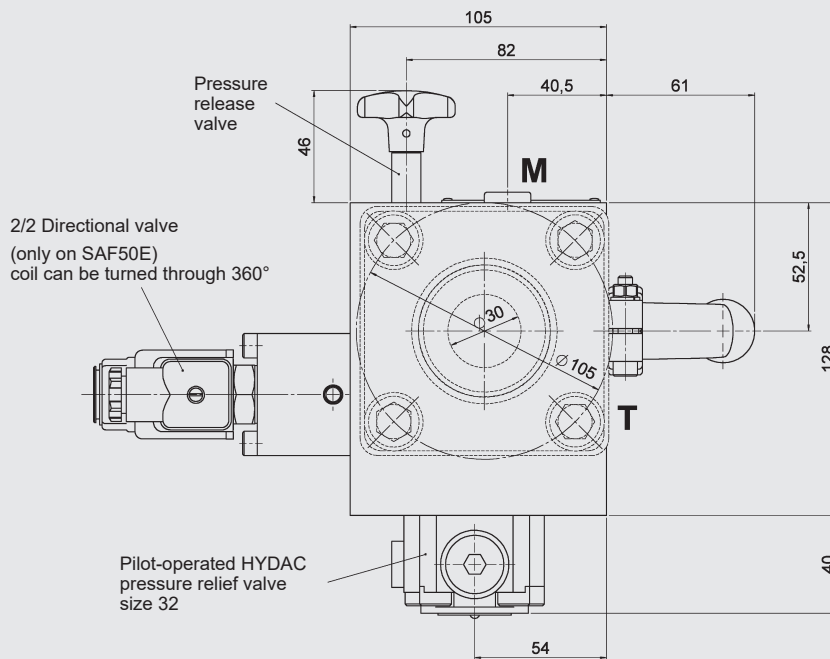

Pilot-operated HYDAC pressure relief valve size 32

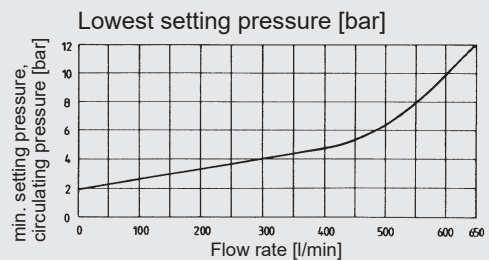
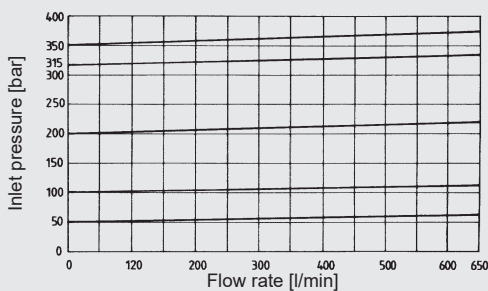

SA32E29TVY

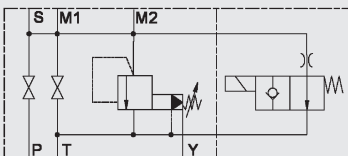

SA32E29TV

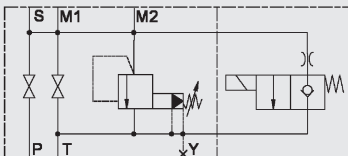

SA32M29TVY

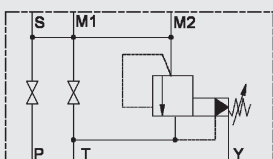

SA32M29TV

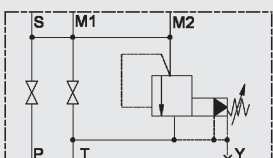

The safety and shut-off block SA32M(E)29 is equipped with a pilot-operated pressure relief valve size 32 for high flow rates up to 600 l/min.

The E type of the safety and shut-off block has a solenoid-operated 2-way directional valve for automatic pressure release of the accumulator and the hydraulic system in an emergency or for shut-down.

For unpressurised tank lines, valve type "TV" must be used (with internal pilot oil return to tank).

For pressurised tank lines, valve type "TVY" is recommended (with external pilot oil return to tank).

Two different models of the 2-way directional valve are available:

- WSM06020Y (normally open)
- WSM06020Z (normally closed)

Type	Weight
SA32M29...	22.5 kg
SA32E29...	23.5 kg

5.4. SAF8M

For pressures of 400 bar and above in stainless steel with high-pressure ports
(max. operating pressure 800 bar, max. perm. flow rate safety valve: 0.95 l/min)

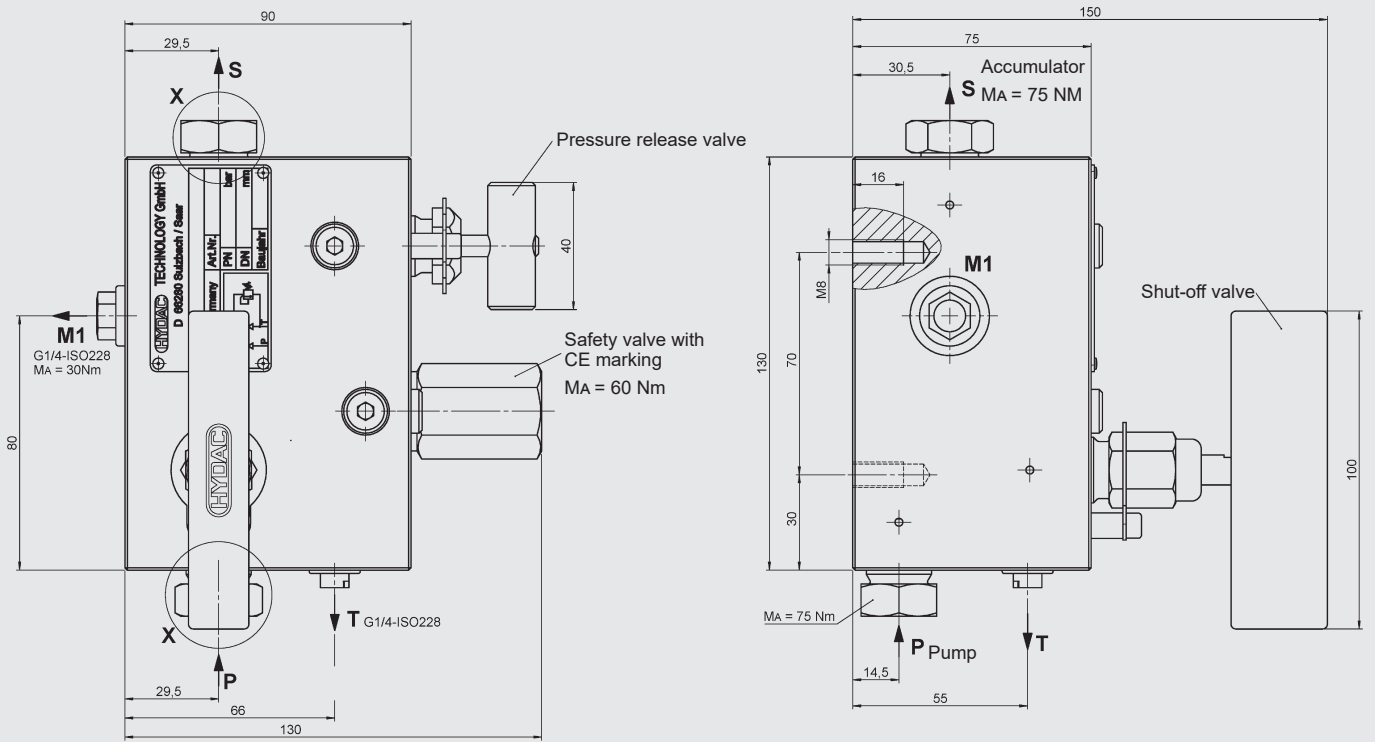

X (1:1)

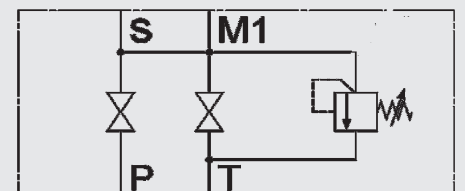
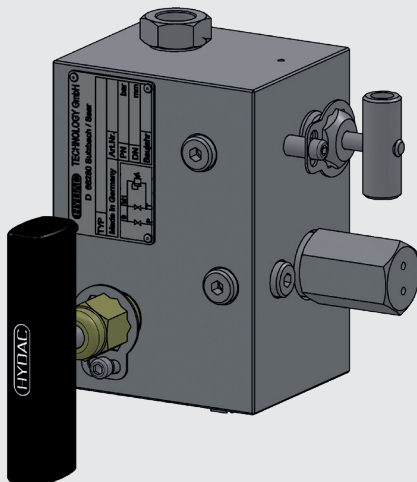
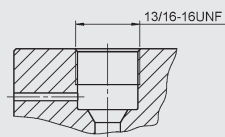
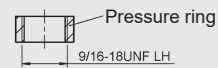
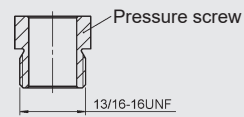
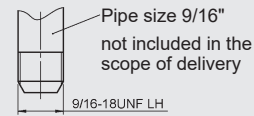

Type	Weight
SAF8M	7.5 kg

5.5. SAFETY AND SHUT-OFF BLOCK WITH 2-WAY CARTRIDGE VALVE (LOGIC ELEMENT)

This safety and shut-off block consists of a valve block, an integrated pressure relief valve and a solenoid-operated 2-way cartridge valve which replaces the main shut-off valve.

Advantages:

In addition to its compact design, this model is capable of rapid switching to control the fluid flow.

5.5.1 Function when using 4/2 direction valve

When the 4/2 directional valve is in the switching position shown (open when de-energised), the spring chamber of the logic element is pressurised via the accumulator pressure; the path from P to S is blocked and the hydraulic accumulator is shut off from the system. By connecting the accumulator via the orifice in the pilot valve to the tank, it will slowly discharge.

When the 4/2 directional poppet valve is in the discharge position (energised) the spring chamber of the logic element is discharged, the path from P to S is open and the accumulator is charged.

Specifications:

Type	Nominal size	Max. operating pressure	Pressure relief valve ¹⁾
SA20A50T...	DN20	400 bar	DB12 (2)
SA32A50T...	DN30	400 bar	DB12 (3)

¹⁾ Number of pressure relief valves

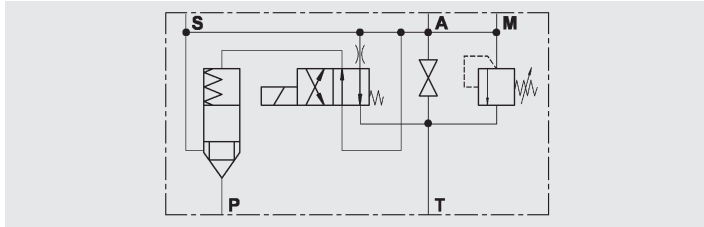

Type	Nominal size	Max. operating pressure	Pressure relief valve ¹⁾
SA20E50T...	DN20	400 bar	DB12 (2)
SA32E50T...	DN30	400 bar	DB12 (3)

¹⁾ Number of pressure relief valves

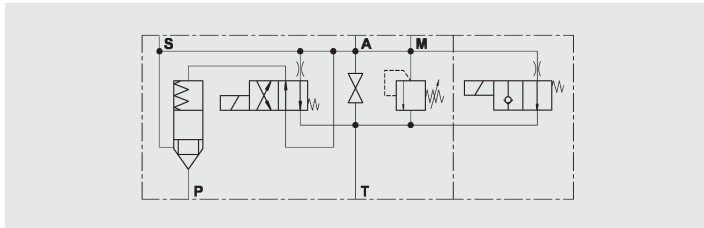

5.5.2 Function when using 3/2 directional poppet valve

When the 3/2 directional poppet valve is in the switching position shown (open when de-energised), the spring chamber of the logic element is pressurised via the system pressure; the path from P to S is blocked and the hydraulic accumulator is shut off from the system. When the 3/2 directional poppet valve is in the discharge position (energised) the spring chamber of the logic element is discharged, the path from P to S is open and the hydraulic accumulator is charged.

If the pump breaks down or if it is switched off, the 3/2 directional poppet valve reverts to the "open when de-energised" position; the accumulator pressure shuts off the logic element via the shuttle change-over valve and shuts off the hydraulic accumulator from the system.

Specifications:

Type	Nominal size	Max. operating pressure	Pressure relief valve ¹⁾
SA20A51T...	DN20	400 bar	DB12 (2)
SA32A51T...	DN30	400 bar	DB12 (3)

¹⁾ Number of pressure relief valves

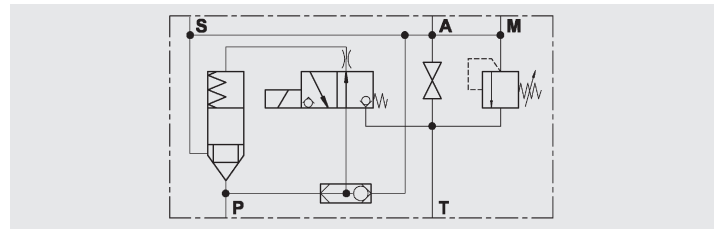

Type	Nominal size	Max. operating pressure	Pressure relief valve ¹⁾
SA20E51T...	DN20	400 bar	DB12 (2)
SA32E51T...	DN30	400 bar	DB12 (3)

¹⁾ Number of pressure relief valves

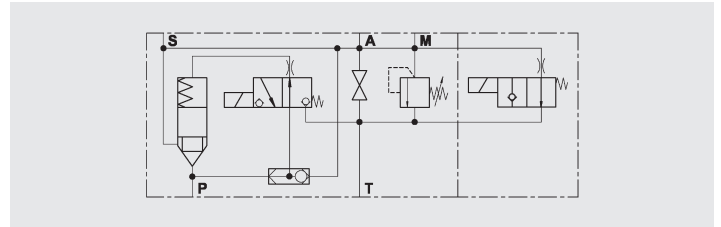

5.6. DSV10 PRESSURE RELIEF VALVE

The three-way DSV10 safety block is used to isolate and discharge hydraulic accumulators and consumers. It complies with the relevant safety standards in accordance with DIN EN 4413 and the German Industrial Safety Regulation BetrSichV. The HYDAC DB12 pressure relief valve is used with the DSV series. It is a direct-acting pressure relief valve in a poppet valve design with excellent opening and closing characteristics. This version of the DB12 complies with the requirements of the European Pressure Equipment Directive (PED) with CE marking.

For further details and technical data, see brochure:

- 3-way safety block – DSV
No. 5.251

6. ACCESSORIES

6.1. ADAPTERS FOR DIAPHRAGM ACCUMULATORS

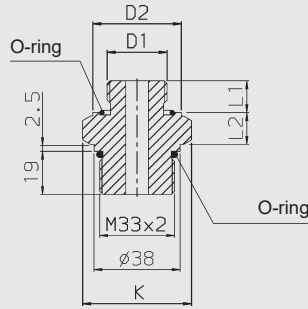

Type	Accumulator type	Nominal volume [l]	D1 thread	Adapter	Part no. ¹⁾ NBR/carbon steel	K AF	L1 [mm]	L2 [mm]	D2 [mm]	O-ring
SAF10/20 DSV10	SBO...E-	0.075 ... 1.4	G 1/2 A	S 30	369485*	41	14	17.5	33	22x3
	SBO...A6-	0.1 ... 0.6		S 31						
	SBO...E-	2.0 ... 3.5	G 3/4 A	S 30	369485*		14	17.5	33	22x3
	SBO...A6-	1.3 ... 4		S 31						

* Preferred models

¹⁾ Others on request

6.2. ADAPTERS FOR PISTON ACCUMULATORS

6.2.1 Standard piston accumulator

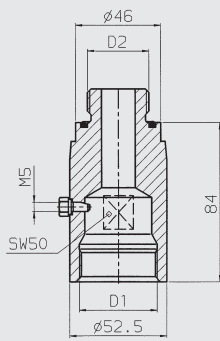

Fig. 1

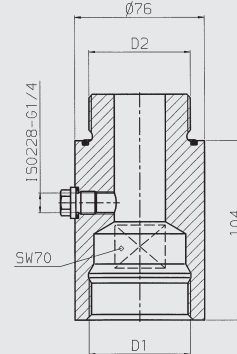
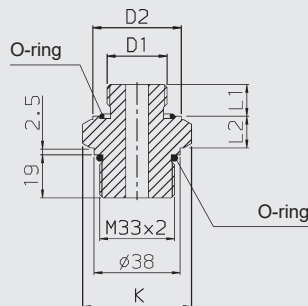

Fig. 2

Type	Accumulator type	Nominal volume [l]	Adapter	Part no. ¹⁾ NBR/carbon steel	D1 [mm]	D2 [mm]	O-ring	Corresponding S adapter	Part no. ¹⁾ NBR/carbon steel	Fig.
SAF10/20 DSV10	SK210/350 -	2.5 ... 7.5	K 406	374929	G 1 1/4	G 1	35x3	S 12	369480	1
	SK210/350 -	10 ... 45	K 408	374931	G 2	G 1 1/2	53x3	S 13	369481	2
SAF32	SK210/350 -	50 ... 120	K 409	374933		G 2	62x3	S 309	366715	

¹⁾ Others on request

6.2.2 SK280



Type	Accumulator type	Fluid port SK280	D1 thread	Adapter	Part no. ¹⁾ NBR/carbon steel	K AF	L1 [mm]	L2 [mm]	D2 [mm]	O-ring
SAF10/20 DSV10	SK280	AAE	G 1/2 A	S 30	369485*	41	14	17.5	33	22x3
		AAF	G 3/4 A	S 31						
		AAE	G 1 A	S 32	369487		46	18	18.5	45

* Preferred models

¹⁾ Others on request

6.3. ADAPTERS FOR BLADDER ACCUMULATORS

6.3.1 Low pressure bladder accumulators

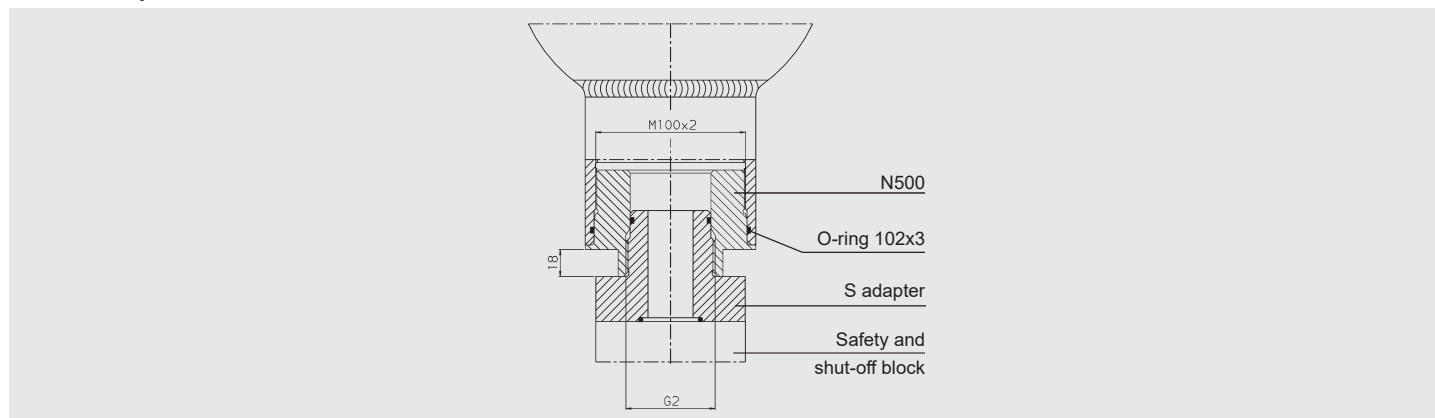

Type	Accumulator type	Nominal volume [l]	Adapter	Part no. ¹⁾ NBR/carbon steel	Corresponding S adapter	Part no. ¹⁾ NBR/carbon steel
SAF10/20 and DSV10 SAF32	SB40	2.5 ... 50	N500	367229	S 13 S 309	369481 366715

¹⁾ Others on request

6.3.2 Standard/high pressure bladder accumulators, threaded connection

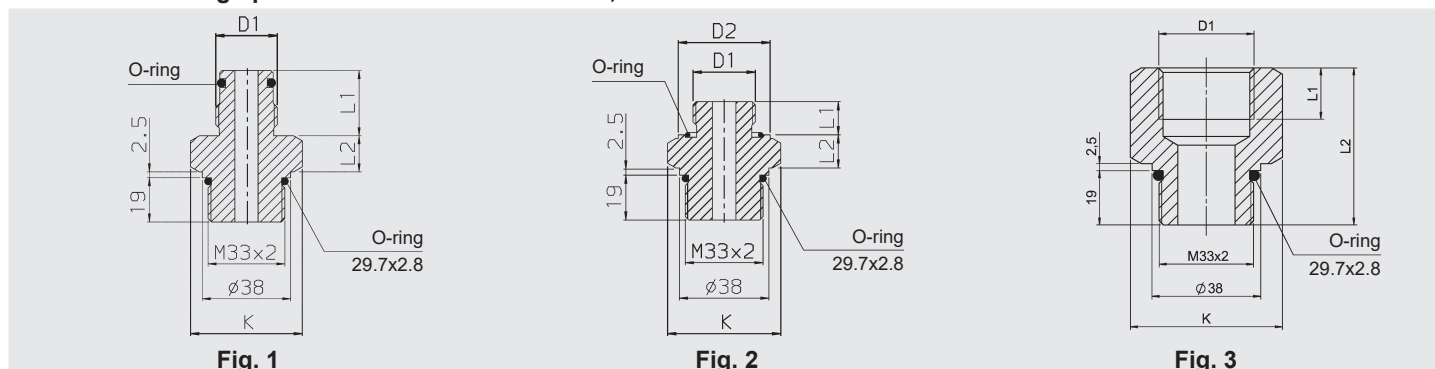

Type	Accumulator type	Nominal volume [l]	D1 thread	Adapter	Part no. ¹⁾ NBR/carbon steel	K AF [mm]	L1 [mm]	L2 [mm]	D2 [mm]	O-ring [mm]	Fig.	
SAF10 SAF20 DSV10	SB330/400-	0.6 ... 1	G 3/4A	S 10	369479*	41	28	16	—	17x3	1	
	SB550/690-	1 ... 5	G 1A	S 11	372750	46	34	17	—	22x3		
	SB330/400-	2.5 ... 6	G 1 1/4A	S 12	369480*		37		—	30x3		
	SB330/400/ 550/600-	10 ... 50	G 2A	S 13	369481*	65	44	21	—	48x3		
	Connection with metric fine thread	—	—	M30x1.5	S 20	369482	41	15	18	40	32x2	2
		—	—	M40x1.5	S 21	369483	55	20	21	54	43x3	
		—	—	M50x1.5	S 22	369484	65			64	53x3	
SB330/400-	2.5 ... 50	G 3/4	S 367861	369489	41	18	50	—	—	3		
		G 1	S 379766	369490	46	20	55	—	—			
		G 1 1/4	S 379767	369498	65	22	60	—	—			

* Preferred models

¹⁾ Others on request

6.3.3 Standard/high pressure bladder accumulators, flange connection

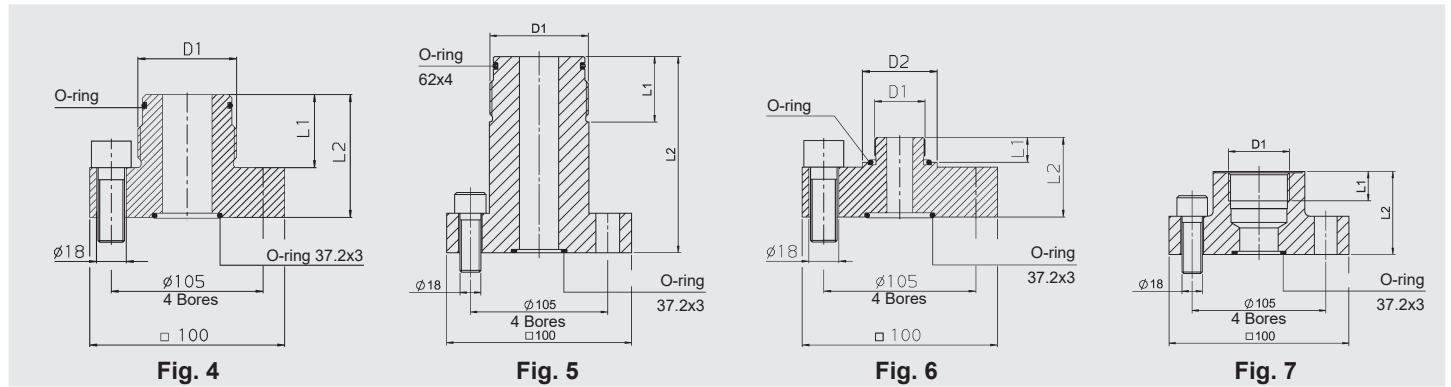

Type	Accumulator type	Nominal volume [l]	D1 thread	Adapter	Part no. ²⁾ NBR/carbon steel	L1 [mm]	L2 [mm]	D2 [mm]	O-ring [mm]	Fig.
SAF32	SB330/400-	0.6 ... 1	G 3/4A	S 305 ¹⁾	366723	28	58	—	17x3	4
	SB550/690-	1 ... 5	G 1A	S 306 ¹⁾	2102855	34	64	—	22x3	
	SB330/400-	2.5 ... 6	G 1 1/4A	S 307 ¹⁾	366724	37	67	—	30x3	
	SB330/400/600-	10 ... 50	G 2A	S 309 ¹⁾	366715*	44	74	—	48x3	5
	SB550-	10 ... 50		S 308 ¹⁾	376813		115	—	—	
	SB330H-	10 ... 50	G 2 1/2A	S 365922	377283	50	150	—	62x4	6
	Connection with metric fine thread	—	M30x1.5	S 330 ¹⁾	366735	15	47	45	32x2	
		—	M40x1.5	S 340 ¹⁾	366736			20	51	
	—	M50x1.5	S 350 ¹⁾	366737	75	53x3				
	SB330/400-	10 ... 50		G 1	S 365637	2106583	20	60	—	—
G 1 1/4				S 369658	2106578	—			—	
G 1 1/2				S 237838	2103869	24			65	—

* Preferred models

¹⁾ Adapter supplied with 4 hex. socket cap screws M16x45 (part no. 6032726) torque 130 Nm

²⁾ Others on request

6.3.4 High pressure bladder accumulators

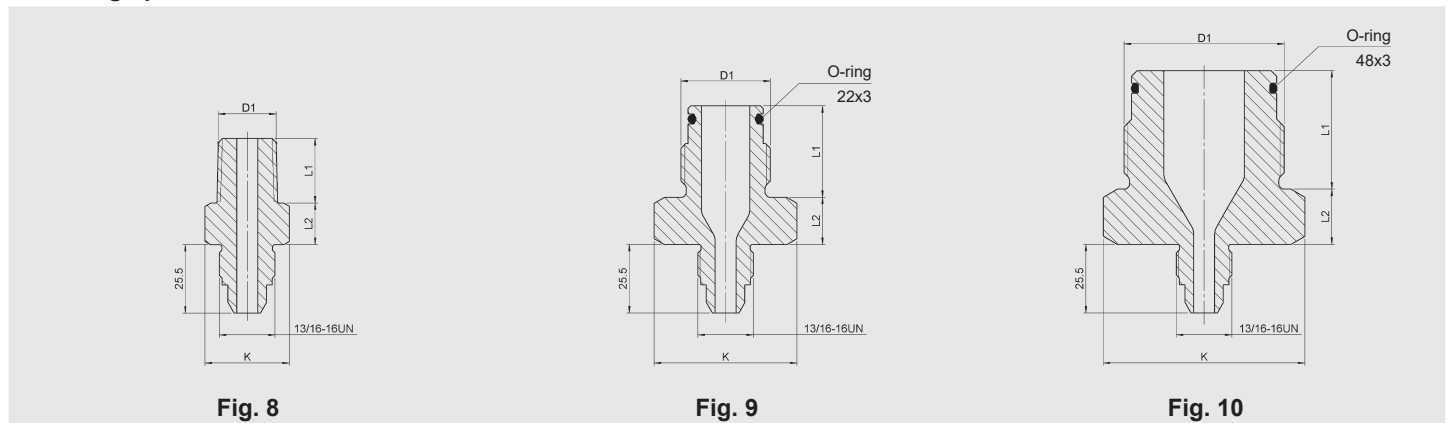

Type	Accumulator type	Nominal volume [l]	D1 thread	Adapter	Part no. ²⁾ Stainless steel	K AF [mm]	L1 [mm]	L2 [mm]	D2 [mm]	O-ring [mm]	Fig.
SAF8	SB690	1 ... 54	1/2" NPT	S3936571	3936571	27	27	15.5	—	—	8
	SB550	≤ 5	G 1	S3956412	4158378 ¹⁾	46	34	17.5	—	22.3	9
	SB500	≥ 10	G 2	S3961814	4158379 ¹⁾	65	44	20.5	—	48.3	10

¹⁾ NBR O-ring

²⁾ Others on request

6.4. GAUGE SHUT-OFF VALVE

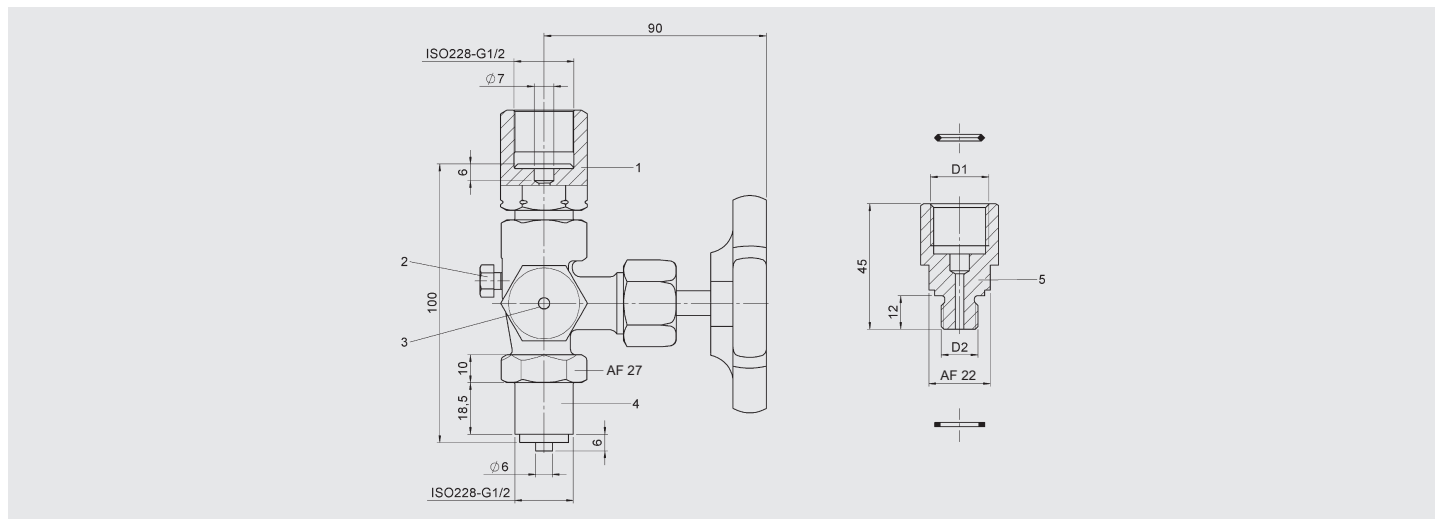

Part no.	Description	Thread		Consisting of:	Item
		D1	D2		
611903	Shut-off valve AG DIN 16271	-	-	Pressure release valve	2
				Female to female threaded connection	1
				Female to male threaded connection	4
				Test point	3
370754	Adapter PA G1/4A-G1/2	G 1/2	G 1/4A		5

6.5. ADDITIONAL DEVICES FOR RETROFITTING

HYDAC supplies the following additional devices for retrofitting to prevent accidental alteration of the position of the shut-off valve or the pressure release valve on the SAF block. For mounting onto the SAF, see section 5. Additional equipment for safety and shut-off blocks.

6.5.1 Lockable main shut-off valve (locking device) - L

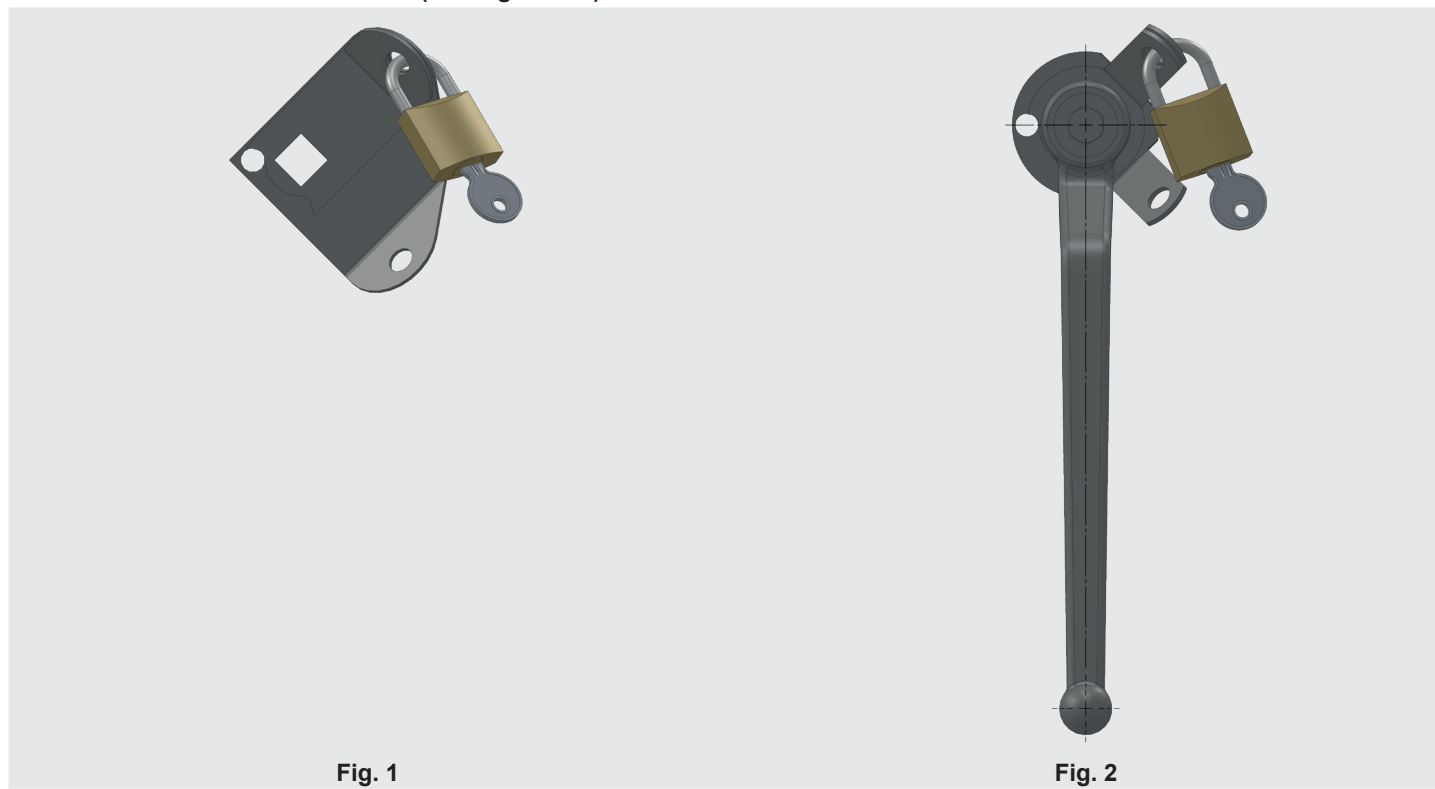
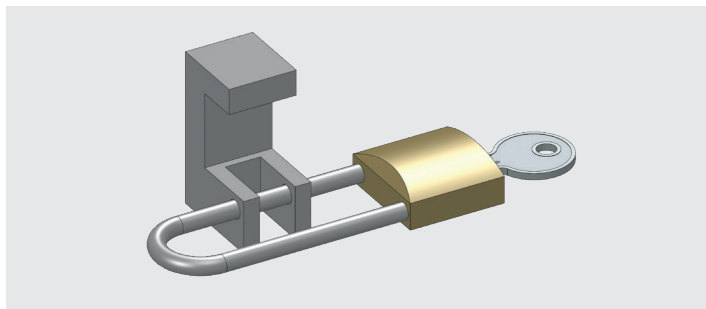

Fig. 1

Fig. 2

Part no.	Designation	Consisting of:	Fig.
4334727	Lockable main shut-off valve for SAF10	Plates	1
		Padlock	
4334730	Lockable main shut-off valve for SAF20	Plates	2
		Padlock	
4334731	Lockable main shut-off valve for SAF32	Plates	2
		Padlock	
		Switching handle	
		Screw	

6.5.2 Lockable pressure release valve - LS



Part no.	Designation	Consisting of:
3580490	Spindle lock SAF	– Spindle lock SAF – Padlock

6.6. ACCUMULATOR CHARGING VALVE



HYDAC accumulator charging valves control the charging of the accumulator within an adjustable switching range. By combining the charging valve with an accumulator, pumps and motors on oil-hydraulic systems with fluctuating flow requirements can be sized smaller. This saves costs and energy - thus preventing unnecessary heat generation.

For further information and technical specifications, see brochures:

- DLHSD DLHSR Accumulator charging valve
No. 5.190.1
- Accumulator charging valve DL10-01
No. 5.199.9

7. NOTE

The information in this brochure relates to the operating conditions and fields of application described. For applications and/or operating conditions not described, please contact the relevant technical department. Subject to technical modifications.

HYDAC Technology GmbH
Industriegebiet
66280 Sulzbach/Saar, Germany
Tel: +49 68 97 / 509 - 01
Internet: www.hydac.com
E-mail: speichertechnik@hydac.com

