

HYDAC

INTERNATIONAL

**Valve Technology
and Special Solutions
for Transmissions
on Mobile Machines**

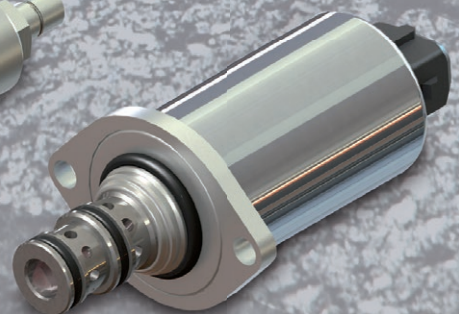
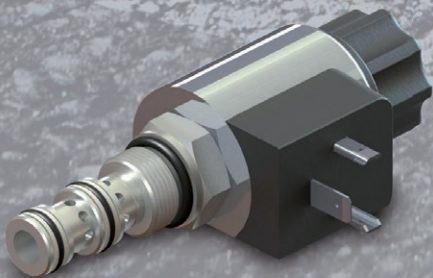
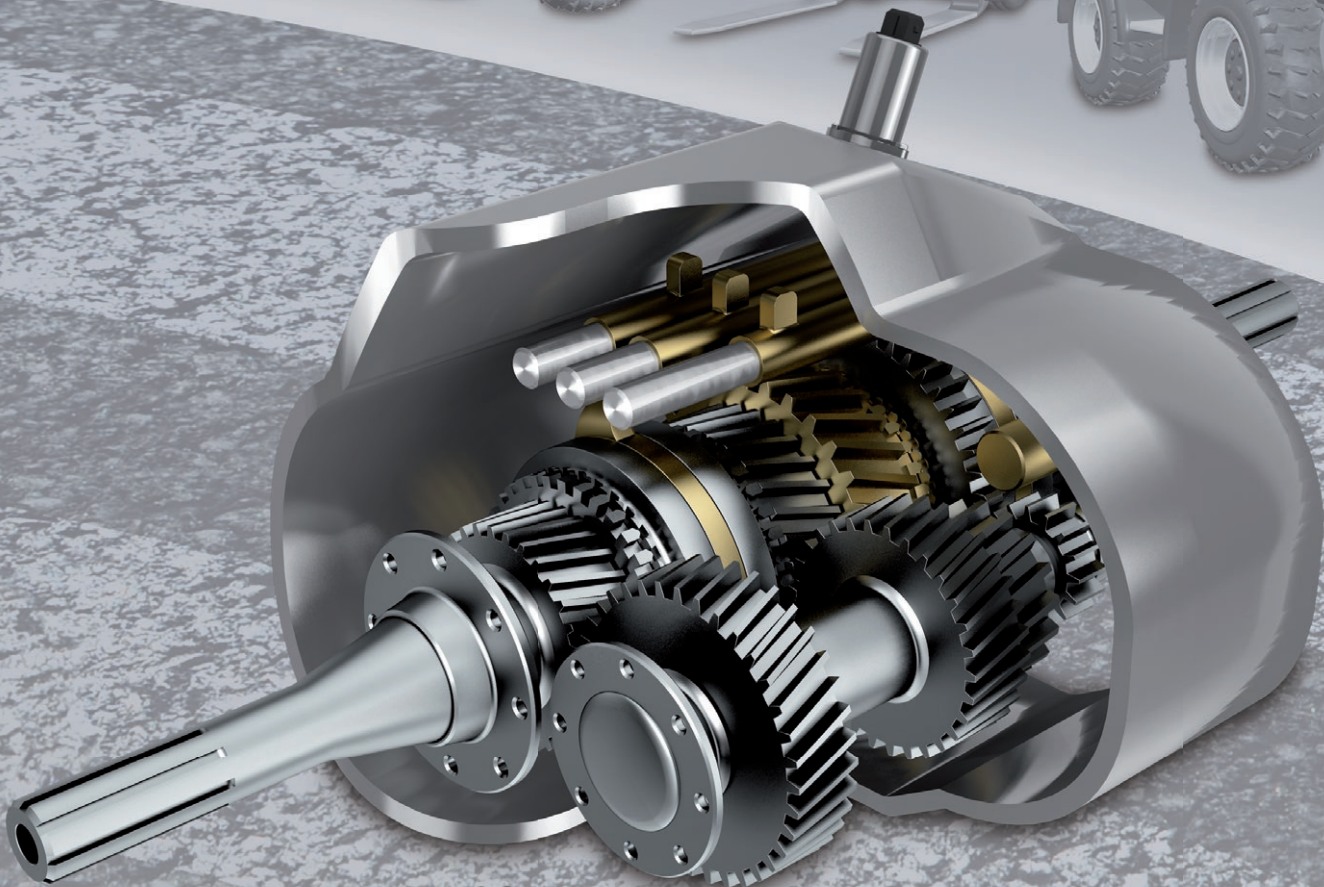

Your partner for expertise in solutions specific to mobile transmissions

Innovative and tailored valve solutions for modern mobile transmission applications

Valves are used in transmission controls to control and limit actuators in a wide variety of transmission types for mobile machines.

HYDAC has a comprehensive range of valves specially designed for transmission applications. Products include direct-acting and pilot-operated hydraulic valves, control valves and proportional valves, which are available in slip-in or cartridge designs.

Valve technology from HYDAC offers you the following advantages:

- Consultation and collaborative development of tailored solutions
- Cost optimisation and efficiency
- Contamination-tested and optimised design

Our range of valves offers maximum performance in terms of:

- Optimised clutch relief
- Excellent performance in high viscosity oil
- Pilot-operated valves with no loss of pilot oil
- Special switch-on and reset currents for low voltages

Note

The information in this brochure relates to the operating conditions and applications described. For applications or operating conditions not described, please contact the relevant technical department.

Subject to technical modifications.

HYDAC offers a broad range of application-specific solutions in the field of transmission valves. Each type of valve excels in its application and has the edge on similar products available on the market in terms of functionality.

An important distinguishing feature is the switching time in high viscosity oil for applications such as powershifting in agricultural machinery transmissions. For example, the HYDAC direct-acting PDR08-50 proportional pressure reducing valve achieves switching times of less than 50 ms for a viscosity of 2,000 cSt and at realistic flow rates.

See **Fig. 2** for an overview of the switching times. This valve ensures trouble-free powershifting in tractors even at temperatures below -20 °C. It eliminates or greatly reduces the need for conventional heating procedures. This important requirement was factored into the design of the valve.

Furthermore, in the area of transmission valves, leakage has been minimised, considerably reducing power loss. HYDAC's PDMC12S30P-15 is a pilot-operated proportional pressure reducing valve for pressures up to 50 bar and for flow rates up to 100 l/min; it has been optimised firstly to be able to control pressure proportionally up to tank pressure (optimised relief of the clutch), and secondly to be able to reduce the usual pilot leakage when de-energised. Compared to previous losses of over 1 l/min, leakage from HYDAC's optimised valves is as little as approx. 50 ml/min at 0 mA (see **Fig. 3**, leakage curve is shown in red).

Given that there might be up to nine valves per gear, a 55 bar supply pressure and over 1 l/min leakage per valve, optimisation measures were able to reduce the power loss by almost 1 kW. Application-specific solutions do not necessarily mean complete re-development, however. Designs can often be optimized to adapt the function precisely to application-specific requirements and to save money. A functional design means a "practical" one, in other words at a reasonable cost. Knowledge of the application and special solutions also lead to the desired result.

Development partnership demonstrates the effectiveness of practical solutions

For example, a long-standing HYDAC customer had already been using proportional valves in their transmissions but was looking for a more cost-effective solution. The customer was attracted to the potential advantages of switching from cartridge valves with a removable coil to Hydac's compact valve range. At the same time the customer did not want to sacrifice the excellent performance they had come to expect.

The advantages of the powerful HYDAC solenoid system, contamination-resistant design and excellent switching times in high-viscosity oil are undisputed. But the eventual solution was developed from application-specific tests. For example, switching times and pressure losses were measured and susceptibility to contamination was determined. However, there is no standard for determining susceptibility to contamination. In an application-specific test similar to the HYDAC multipass test for filters, a valve was flushed with contaminated oil containing standard dust. Next, the resulting performance curves were analysed. Following a logical root cause analysis and subsequent improvements, valve performance was optimised to ensure satisfactory performance at a maximum ISO contamination level of 23/21/16 (**Fig. 4**).

In this way, it was possible to compare the previous product to the more cost-effective solution. At the same time, the function with this ISO code was extraordinary for a proportional valve. To make the series of tests even more realistic, the test was also conducted on a specially designed test bench using real gear abrasion dust. Again, the valve was contaminated with actual dust under realistic conditions, then analysed and improved. Contamination was specified in mg/l, as the results could not be translated into ISO codes. The tests concluded with a continuous duty test of over two million cycles in extremely contaminated oil. Examination of the spool surfaces after the endurance test revealed the abrasive properties of the oil used (**Fig. 5**).

The contamination test yielded a range of insights that were used to improve the valve.

The example demonstrates how high the customer demands placed on the "valve" component are and how much importance is attached to special solutions.

Wide variety of special valves for transmission controls

Using pilot-operated and direct-acting cartridge and slip-in valves

Optimised for specific applications:

- Optimised pressure losses when relieving the clutch
- Special switching currents for safe switching at low voltages
- Excellent performance in high viscosity oil
- Pilot-operated valves with almost no loss of pilot oil
- Contamination-resistant



PDR10830



DB10SE

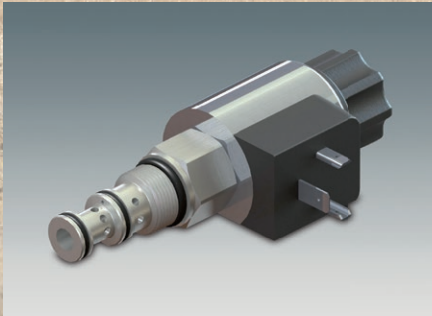

PDR08-50



PDMC05S30A-50



PDR10P-10



DB10SPE-01



PDBC12S21PEZ-C



WK08C-80

Tailored valves and special solutions – developed collaboratively

Regardless of whether the manufacturer is in the agricultural industry or the construction machinery sector or whether the terms of reference relate to the machine tool industry or industrial hydraulics in system engineering: the customer is almost always looking for ways to improve performance to distinguish their product from those of competitors. The key to this is to tailor innovative components to the customer's system.

HYDAC coordinates and tailors the development process to meet the needs of customers who want a custom solution and the ideal product for their application.

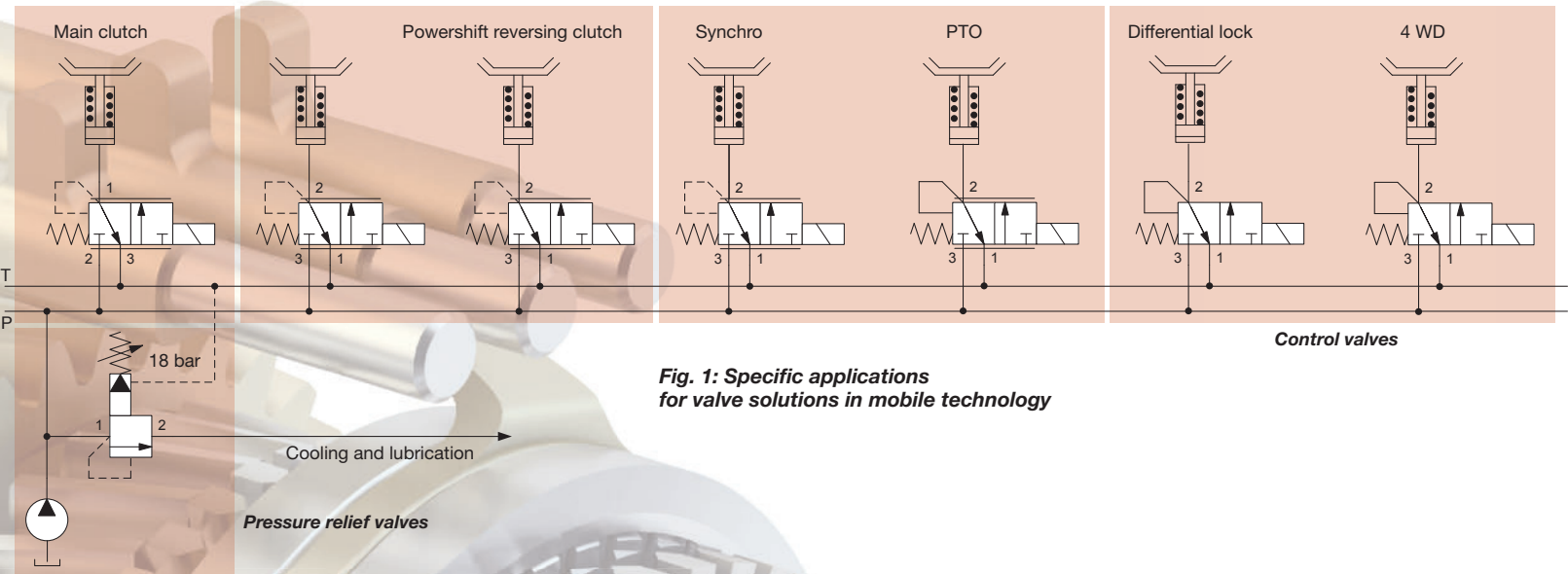

Fig. 1: Specific applications for valve solutions in mobile technology

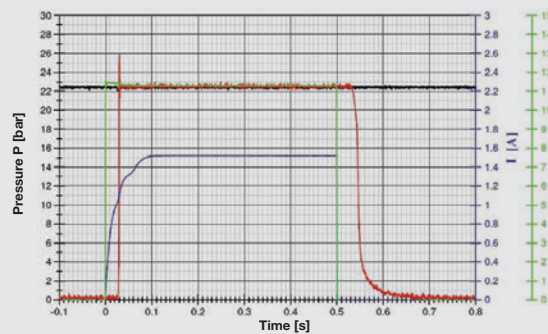

Fig. 2: Switching time at 2000 cSt for PDR08-50

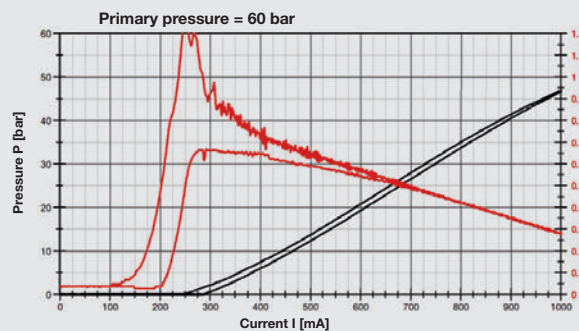

Fig. 3: P – I performance curve for PDMC12S30P-15 (pilot-operated valve with minimised pilot leakage, de-energised)

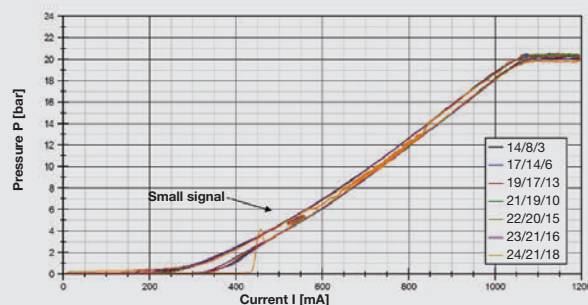

Fig. 4: PDMC valve curve during ISO test

	Proportional pressure reducing valves							3/2-way valves		
	PDR08-50	PDR10830	PDMC05S30A-50	PDMC12S30P-01	PDMC12S30P-15 (integrated minimised pilot leakage)	PDMC10P-10	PDMC10P-10 with optional minimised pilot leakage)	PDR08-02Z	WKC05S30C	WK08C-80
Compact design	●	●						●		●
Extremely compact design			●	●	●				●	
Inverse performance curve								●		
Minimal pressure loss when clutch is relieved	●	●	●	●	●	●	●		●	●
No loss of pilot oil thanks to direct-acting design	●	●	●					●	●	●
Extremely low leakage losses when de-energised	●	●	●		●		●	●	●	●
Extremely fast switching in cold oil	●		●							
Optimised for high contamination tolerance	●	●	●						●	●
Flat control performance curve		●		●	●	●	●			
Designed for optimal inching when clutch is actuated		●		●	●	●	●			
Interchangeability between switching and proportional valve	●		●						●	●

	System pressure valves		Proportional system pressure valves with inverse performance curve	
	DB10SPE	DB10SE	PDB10SPEZ	PDBC12S21PEZ
Inverse performance curve			●	●
No loss of pilot oil thanks to direct-acting design		●		
Flat performance curve for pressure relief (minimal dependency on motor speed)	●	●	●	●
Interchangeability between switching and proportional valve	●	●	●	
Spring chamber drains to tank (3-way pressure-reduction)	●	●	●	●

Pressure reducing valves

Direct-acting proportional pressure reducing valve PDMC05S30A-50

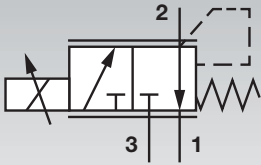
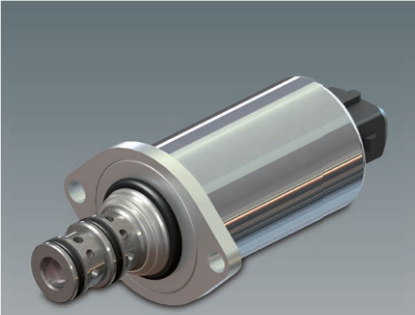

HYDAC PATENT

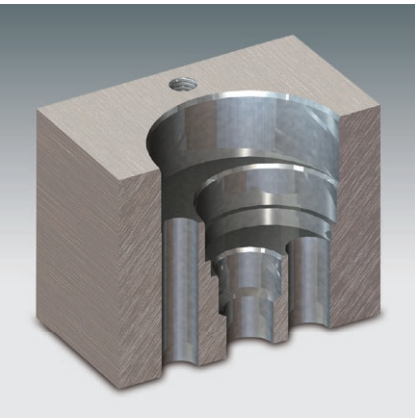

Eccentric cavity

Areas of application:

- Powershift clutches
- PTO
- Actuation of automatic group switches

Features:

- Max. control pressure 20 bar
- Max. flow rate 20 l/min
- Slip-in valve for controlling clutches and actuators
- Extremely compact design
- Minimal pressure loss when clutch is relieved
- No loss of pilot oil thanks to direct-acting design
- Extremely fast switching in cold oil
- Optimised for high contamination tolerance
- Optimised solenoid system available as option for improved resistance to vibration, and extremely low application pressures (less friction, higher dither frequency possible)
- Valve is interchangeable with a control valve with the same connection logic

Comparison of standard and eccentric cavity

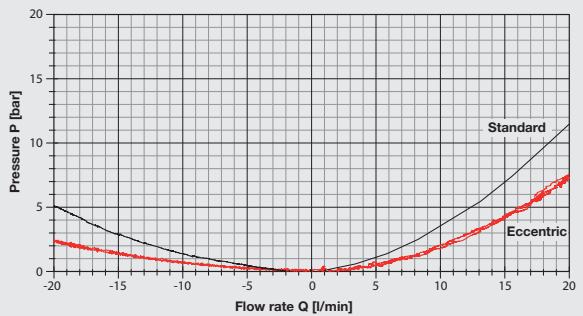

Optional:

PDMC05S30A-50 in eccentric cavity

The eccentric cavity has two key advantages for slip-in valves:

- The pressure loss of the valve is significantly reduced, allowing for faster clutch relief. This is a noticeable advantage when viscosity is high.
- The parallel arrangement of the connecting bores offers huge design advantages. Remarkable cost savings are achieved by dispensing with cross-holes and blanking plugs. Valves can be directly integrated into the transmission housing very easily.
- This has clear advantages, especially when valves are installed in close proximity to actuators.
- Control valve version also available with identical cavities

Direct-acting proportional pressure reducing valve PDR08-50

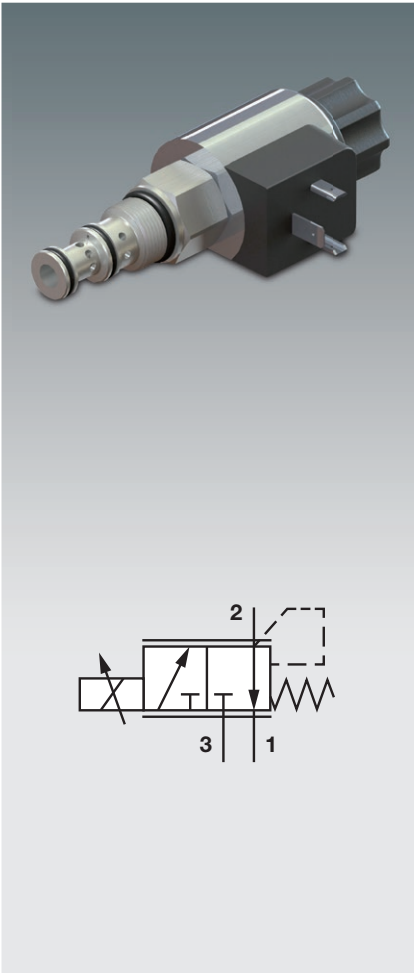

Areas of application:

- Powershift clutches
- PTO
- Actuation of automatic group switches
- Small drive clutches

Features:

- Max. control pressure 20 bar
- Max. flow rate 25 l/min
- Cartridge valve for controlling clutches and actuators
- Compact design
- Minimal pressure loss when clutch is relieved
- No loss of pilot oil thanks to direct-acting design
- Extremely fast switching in cold oil (see performance curve)
- Excellent hysteresis properties
- Optimised for high contamination tolerance
- Flatter performance curve compared to PDMC05S30A-50

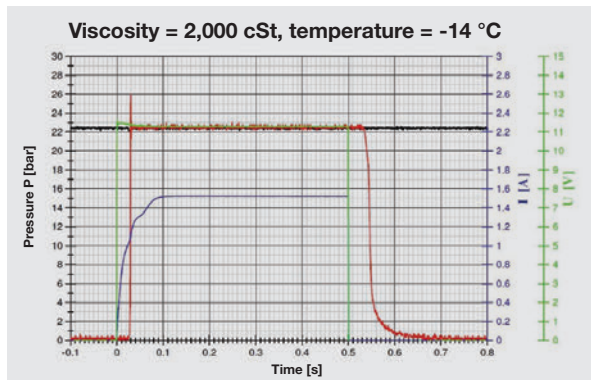

Direct-acting proportional pressure reducing valve PDR10830

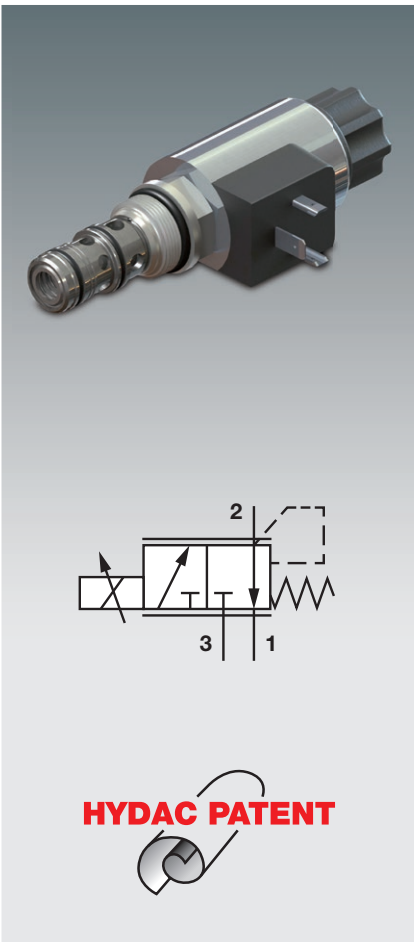

Area of application:

- Large drive clutches

Features:

- Max. control pressure 32 bar (smaller nominal pressures also available)
- Max. flow rate 40 l/min
- Cartridge valve for controlling large drive clutches
- Compact solenoid system with fast control characteristics thanks to low induction (in relation to controlled flow rate)
- Minimal pressure loss when clutch is relieved, allowing for very fast automatic gear-shift.
- No loss of pilot oil thanks to direct-acting design
- Excellent hysteresis thanks to reduced frictional loading
- Designed for optimal inching when drive clutch is actuated manually
- Optimised for high contamination tolerance

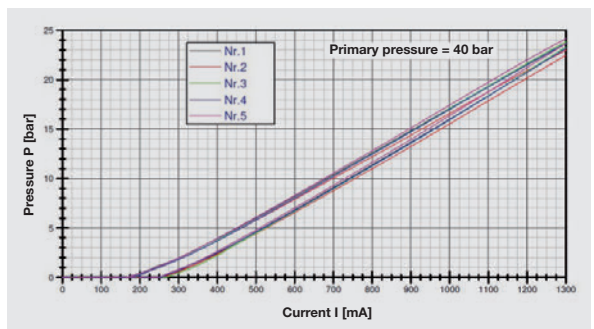

Pressure reducing valves

Pilot-operated proportional pressure reducing valves with minimised pilot leakage when de-energised PDMC12S30P-01 / -15 and PDMC10S30P-01 / -15

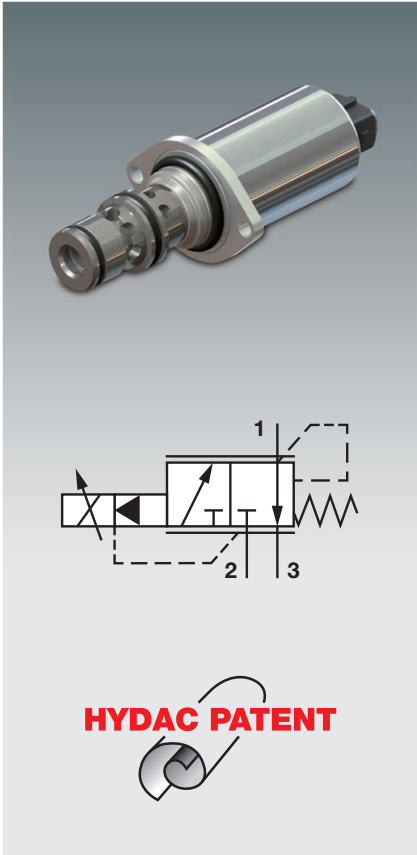

Area of application:

- Clutch supply line with pressure accumulator (recharging cycle extended by factor of 20)

Features:

- Max. control pressure 60 bar (smaller nominal pressures also available)
- **Max. flow rate 100 l/min**
- Slip-in valve for controlling very large clutches
- Minimal leakage when de-energised despite pilot-operated design (minimised leakage)
- Extremely compact compared to commonly available solutions of the same design
- Minimal pressure loss when clutch is relieved
- Extremely flat pressure reducing performance curve
- Excellent hysteresis thanks to reduced frictional loading
- Also available in NG10, max. flow rate 40 l/min (also in version -15)

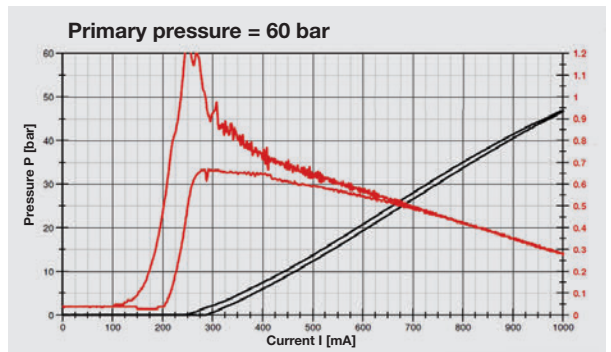
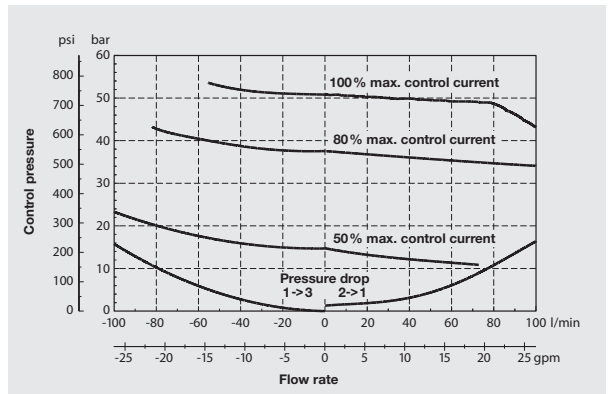

Pilot-operated proportional pressure reducing valve PDMC10P-10

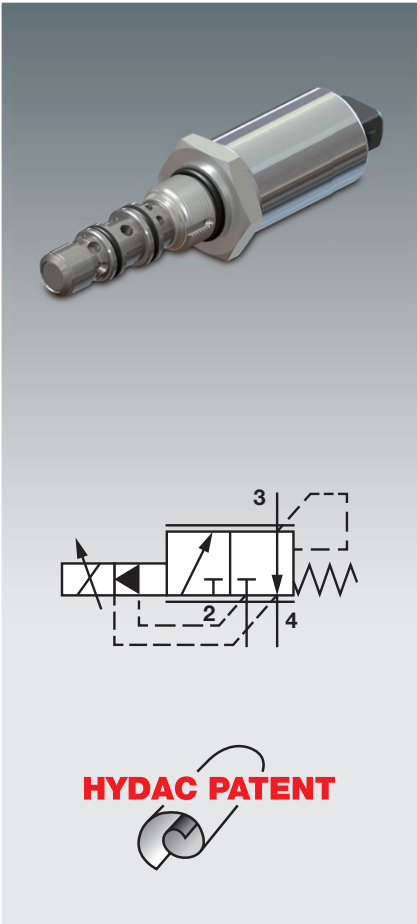

Area of application:

- Large drive clutches

Features:

- Max. control pressure 60 bar (smaller nominal pressures also available)
- Max. flow rate 60 l/min
- Minimal pressure loss when clutch is relieved
- Extremely flat pressure reducing performance curve
- Minimal hysteresis thanks to high-quality solenoid system
- Excellent inching when drive clutch is actuated manually
- Option for minimised leakage when de-energised
- UNF cavity FC10-2 (widely used)

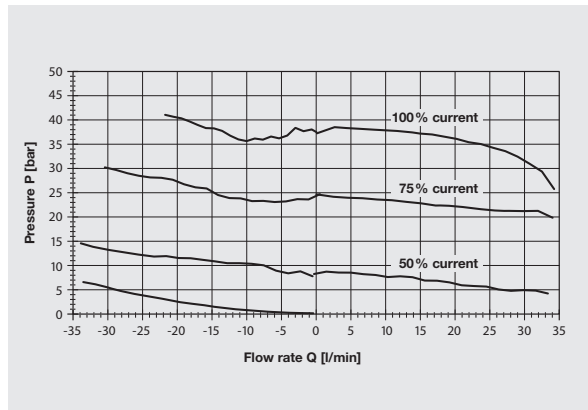

Direct-acting proportional pressure reducing valve with inverse performance curve (fail-safe) PDR08-02Z

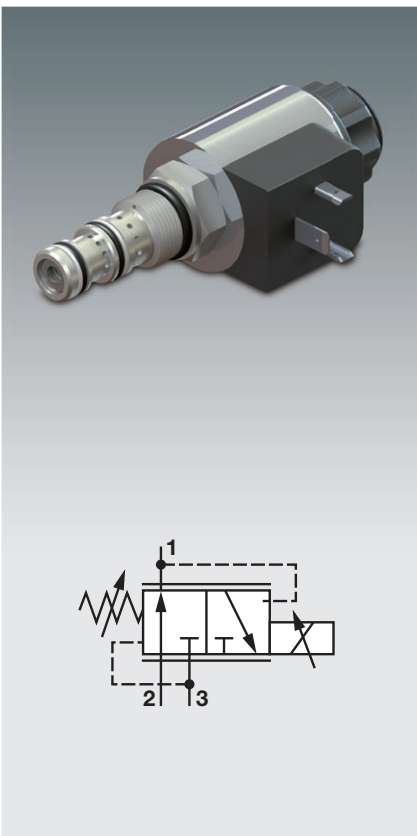

Area of application:

- Reliable shifting of 2-speed hydrostats

Features:

- Max. control pressure 80 bar (smaller control pressures possible)
- Maximum flow rate 10 l/min
- Mechanically adjustable maximum pressure (de-energised)
- No pilot oil
- Large selection of different nominal pressure ranges
- Pilot-operated solution available

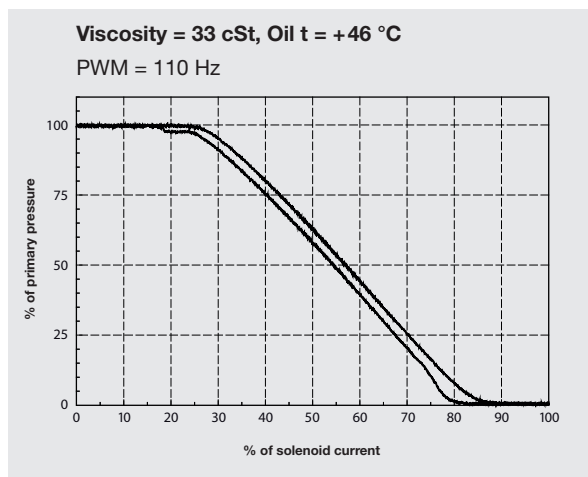

Control valves

Compact direct-acting control valve WKC05S30C

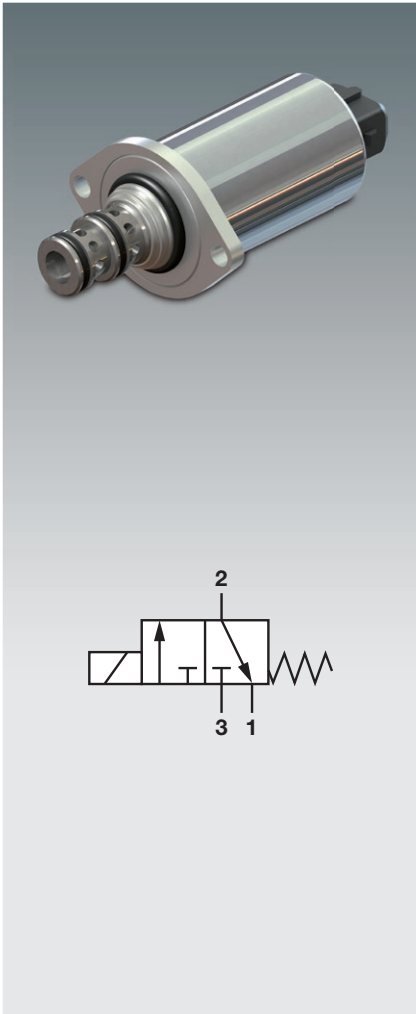

Areas of application:

- All-wheel drive
- Differential lock

Features:

- Max. operating pressure 60 bar
- Max. flow rate 25 l/min
- Interchangeable with PDMC05S30A-50 pressure reducing valve, identical cavities
- Available with optimised switching currents for reliable switching at low voltages (fail-safe)
- Asymmetrical pressure drop for optimised clutch relief
- Also available in eccentric cavity

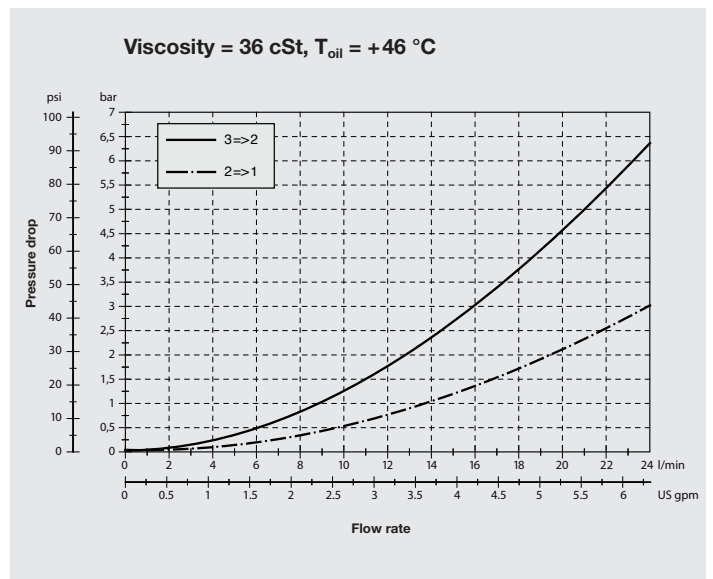

Direct-acting control valve WK08C-01

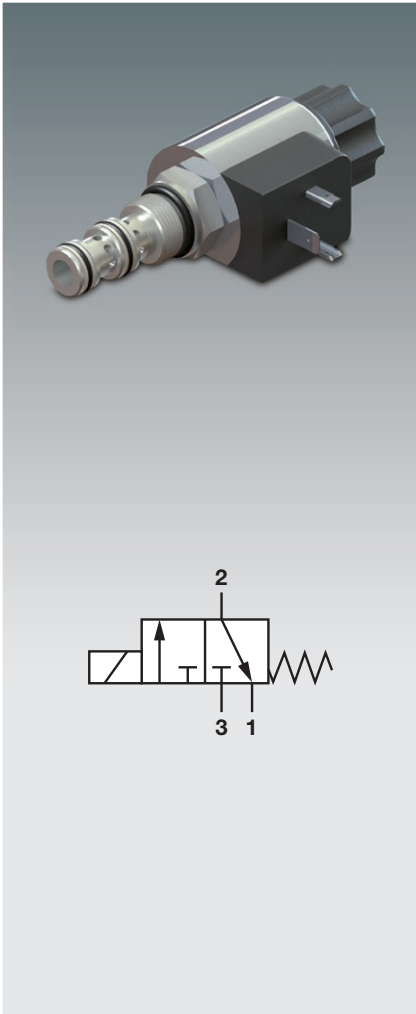

Areas of application:

- All-wheel drive
- Differential lock

Features:

- Max. operating pressure 350 bar
- Max. flow rate 19 l/min
- Interchangeable with PDR08-50 pressure reducing valve, identical cavities
- Available with:
 - Optimised switching currents for reliable switching at low voltages (fail-safe)
 - Optimised pressure loss for fast relief of clutch in cold oil
 - Controlled, minimised leakage when de-energised (e.g. for accumulator-charged parking brake)

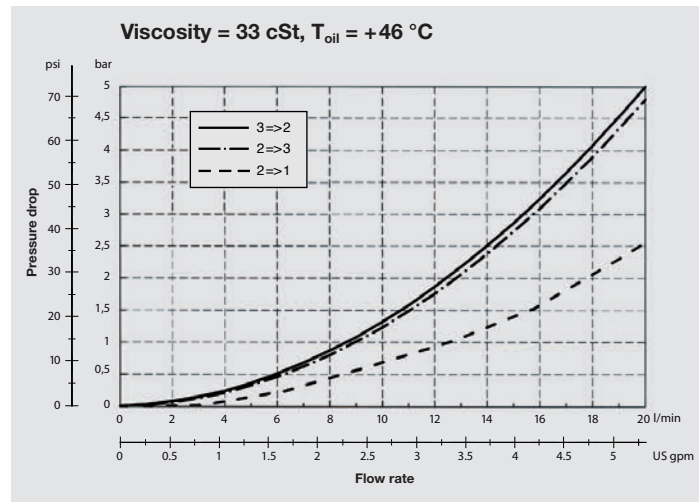

Pressure relief valves

Pilot-operated 3-way pressure relief valve DB10SPE

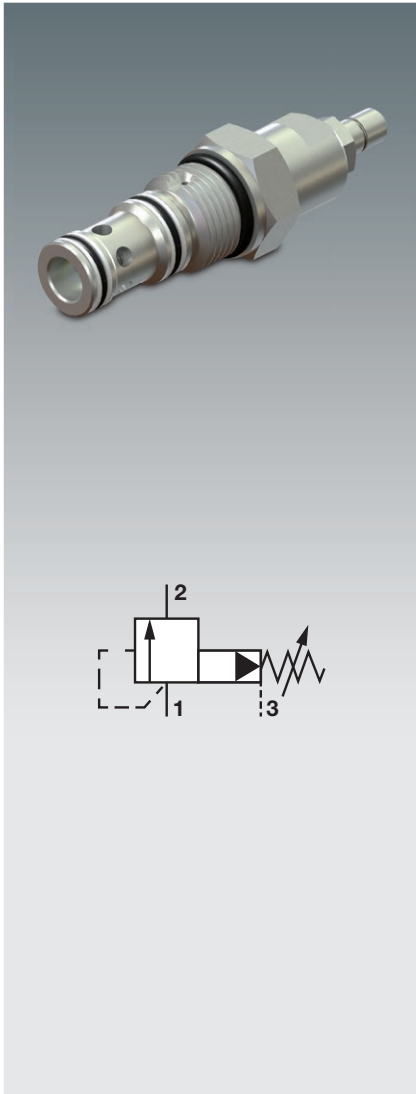

Area of application:

- System pressure reduction in clutch units

Features:

- Max. setting pressure 100 bar (lower nominal pressures also available)
- Max. flow rate 100 l/min
- Cartridge valve
- Guarantees that system pressure in hydraulic transmission systems is unaffected by speed or back-pressure, even when back pressure is high (e.g. via cooler / lubrication during cold start)
- Extremely flat P-Q performance curve
- Extremely compact design
- Extremely stable performance despite flat characteristic curve
- Optimised for high contamination tolerance

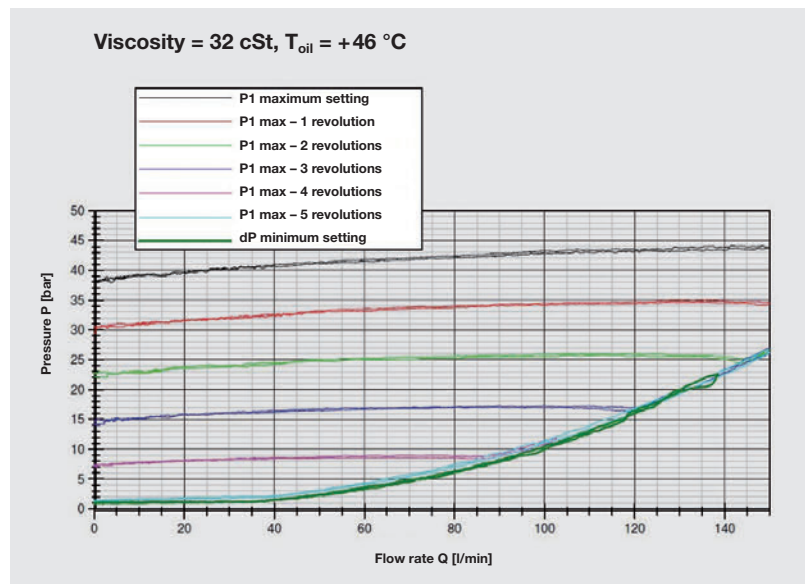

Direct-acting 3-way pressure relief valve DB10SE

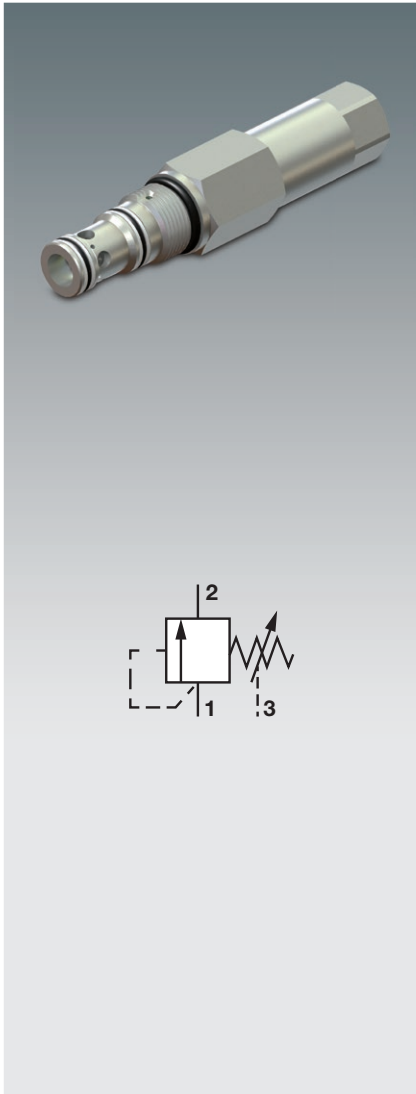

Area of application:

- System pressure control in clutch units

Features:

- Max. setting pressure 24 bar (lower nominal pressures also available)
- Max. flow rate 100 l/min
- Cartridge valve
- Guarantees that system pressure in hydraulic transmission systems is unaffected by speed or back-pressure, even when back pressure is high (e.g. via cooler / lubrication during cold start)
- Extremely flat P-Q performance curve
- Extremely stable performance despite flat characteristic curve (hydraulic damping)
- Despite damping, fast response and minimal overshoot at high viscosities
- Optimised for high contamination tolerance
- Accurate pre-setting by manufacturer

Viscosity = 32 cSt, Oil t = +46 °C

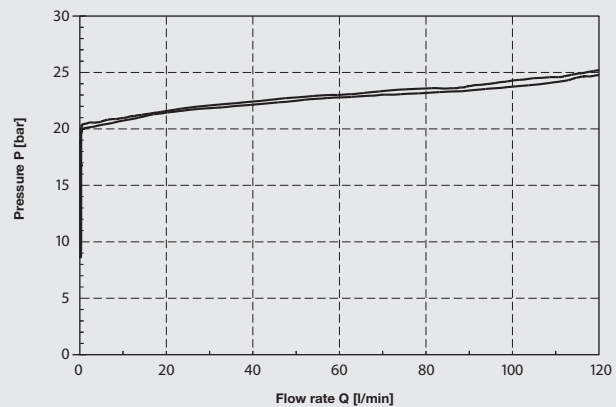

Pressure relief valves

Pilot-operated proportional pressure relief valve with pilot drain – inverse performance curve PDB10SPEZ

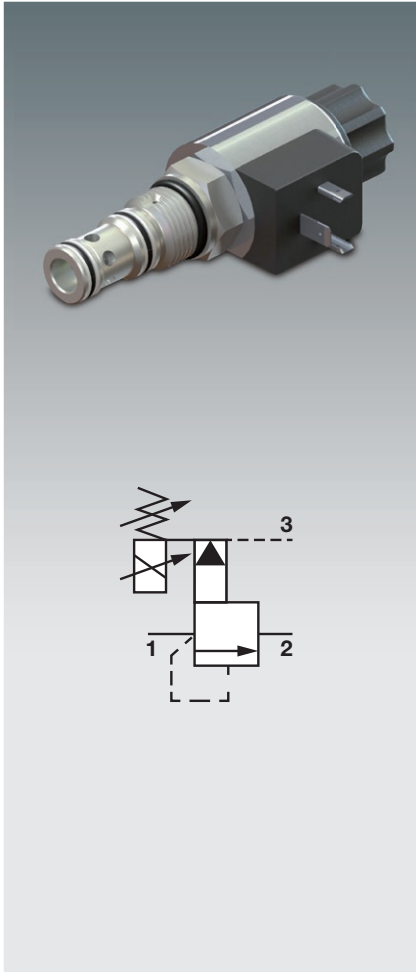

Areas of application:

- To reduce system pressure in hydraulic transmission systems when traction drive is at a standstill (to save energy)
- Temporary boost during overload situations

Features:

- Setting pressure 100 bar, lower pressure ranges available
- Max. flow rate 100 l/min
- Cartridge valve
- Guarantees that system pressure in hydraulic transmission systems is unaffected by speed or back-pressure, even when back pressure is high (e.g. via cooler / lubrication during cold start)
- Extremely flat P-Q performance curve
- Extremely stable performance despite flat characteristic curve
- Maximum pressure can be mechanically adjusted
- Valve can be interchanged with DB10SE and DB10SPE pressure relief valves; can therefore be used in a standard system as an option
- As an option, also available as a normally open valve to enable mechanical adjustment of system pressure (PDB10PY)

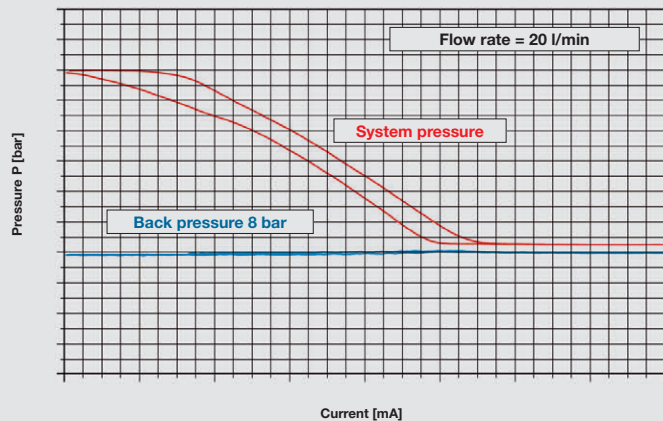

Pilot-operated proportional pressure relief valve with pilot drain – inverse performance curve PDBC12S21PEZ

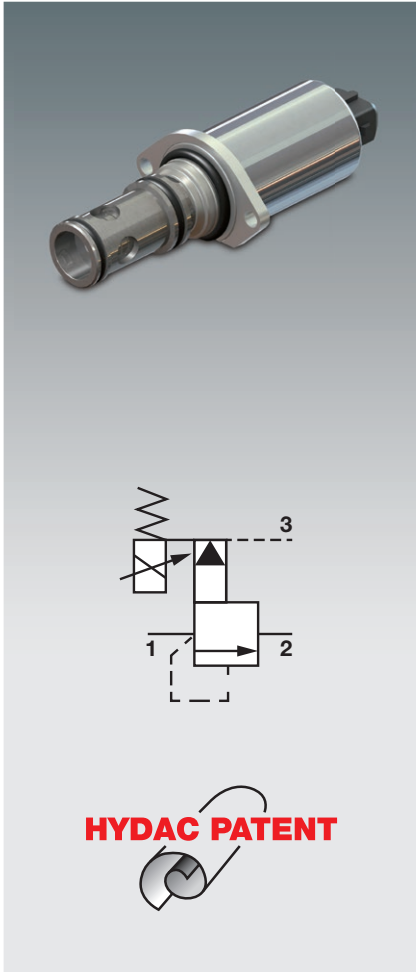

Areas of application:

- To reduce system pressure in hydraulic transmission systems when traction drive is at a standstill (to save energy)
- Temporary boost during overload situations

Features:

- Max. setting pressure 60 bar
- Max. flow rate 250 l/min
- Slip-in valve in cavity optimised for specific applications
- Guarantees that system pressure in hydraulic transmission systems is unaffected by speed or back-pressure, even when back pressure is high (e.g. via cooler / lubrication during cold start)
- Extremely flat P-Q performance curve
- Extremely stable performance despite flat characteristic curve

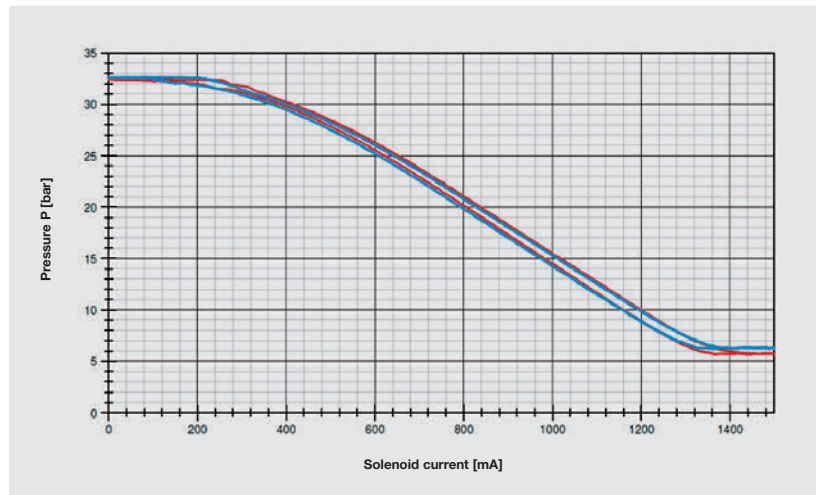
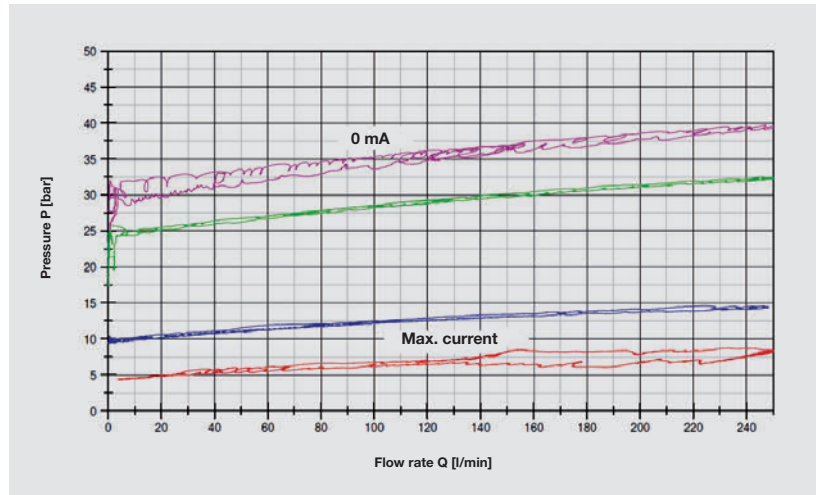

Research and development

Contamination test (DIN)

Valve test in contaminated oil:

Comparison of two proportional pressure reducing valves.

Requirement:

Resistance to contamination and reduced likelihood of failure.

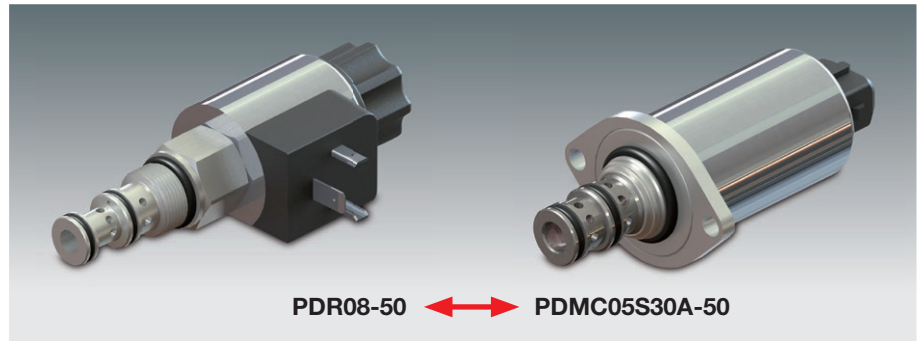

3 different tests

Test based on multipass test



Test based on application-specific contaminated fluids



Design guidelines
→ More resistant valves

Service life test
in contaminated oil

Service life test

- 200 ppm oil
- 2 million cycles (full stroke)

Result:

- Valves withstand the test
- No performance problems
- Highly informative



Pole tube after service life test

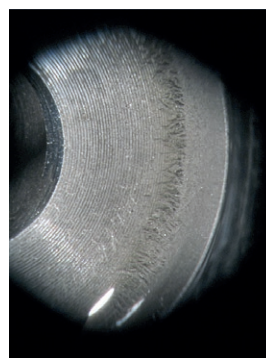

Magnetic deposits in valve

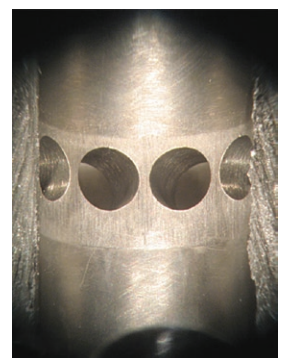

Scratches and abrasions on valve surface

Multipass test

ISO 4406:1999 contamination test

- Standard multipass test
- Procedure similar to contamination test (10 min. dwell time)
- Contamination from 14/8/3 to 25/23/19

Result:

- Valves function up to code 24/22/18

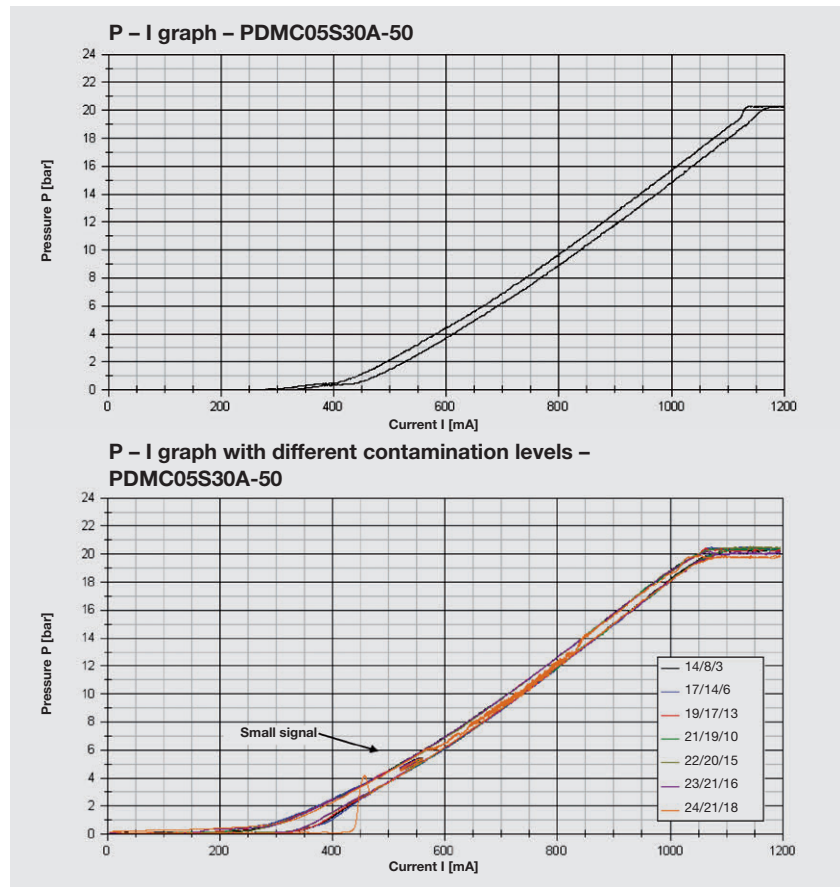
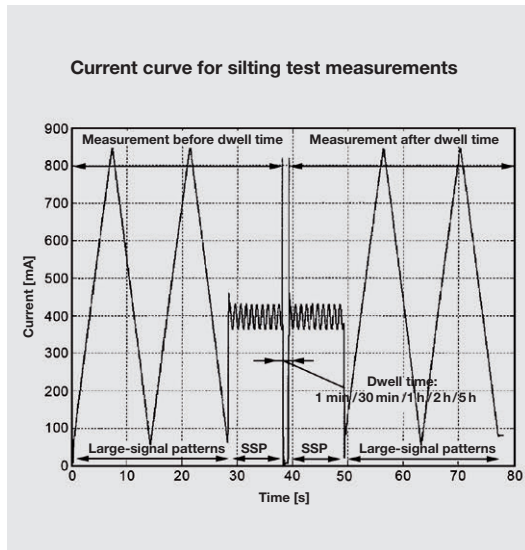

Contamination test

- Using contamination taken from worn gearbox (magnetic separation)
- Concentrations of 20 to 200 ppm
- Horizontal and vertical installation

Result:

- Valves function well, even when extremely contaminated

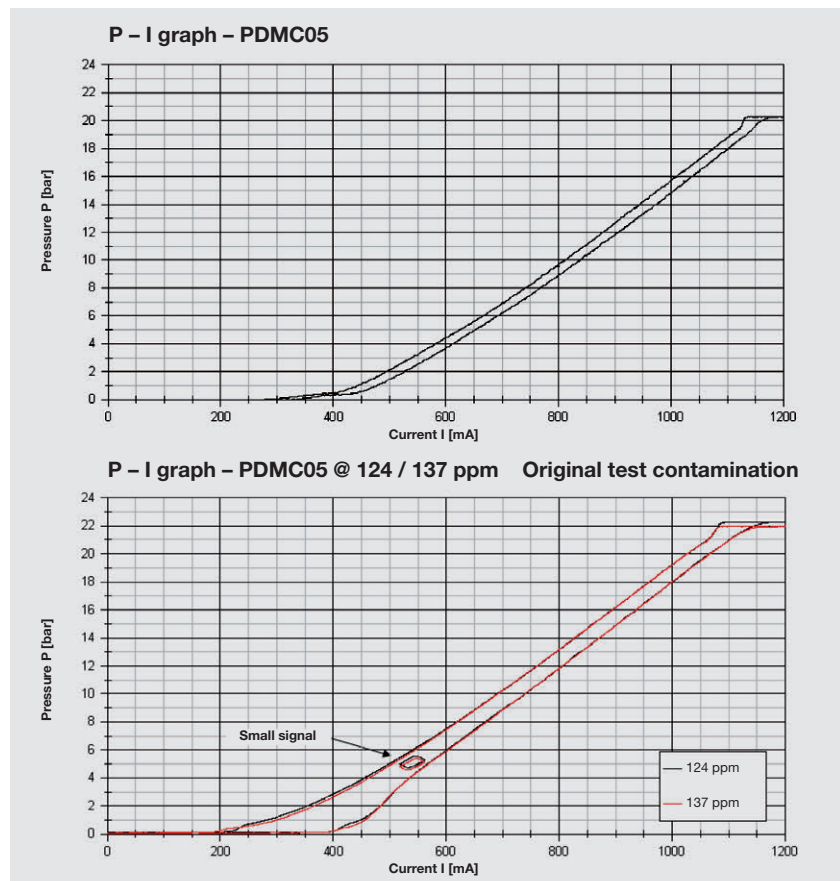



Accumulator Technology 30,000

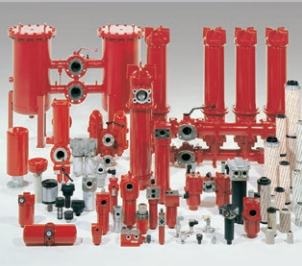

Filter Technology 70,000



Process Technology 77,000



Fluid Service 79,000



Compact Hydraulics 53,000



Accessories 61,000







Electronics 180,000

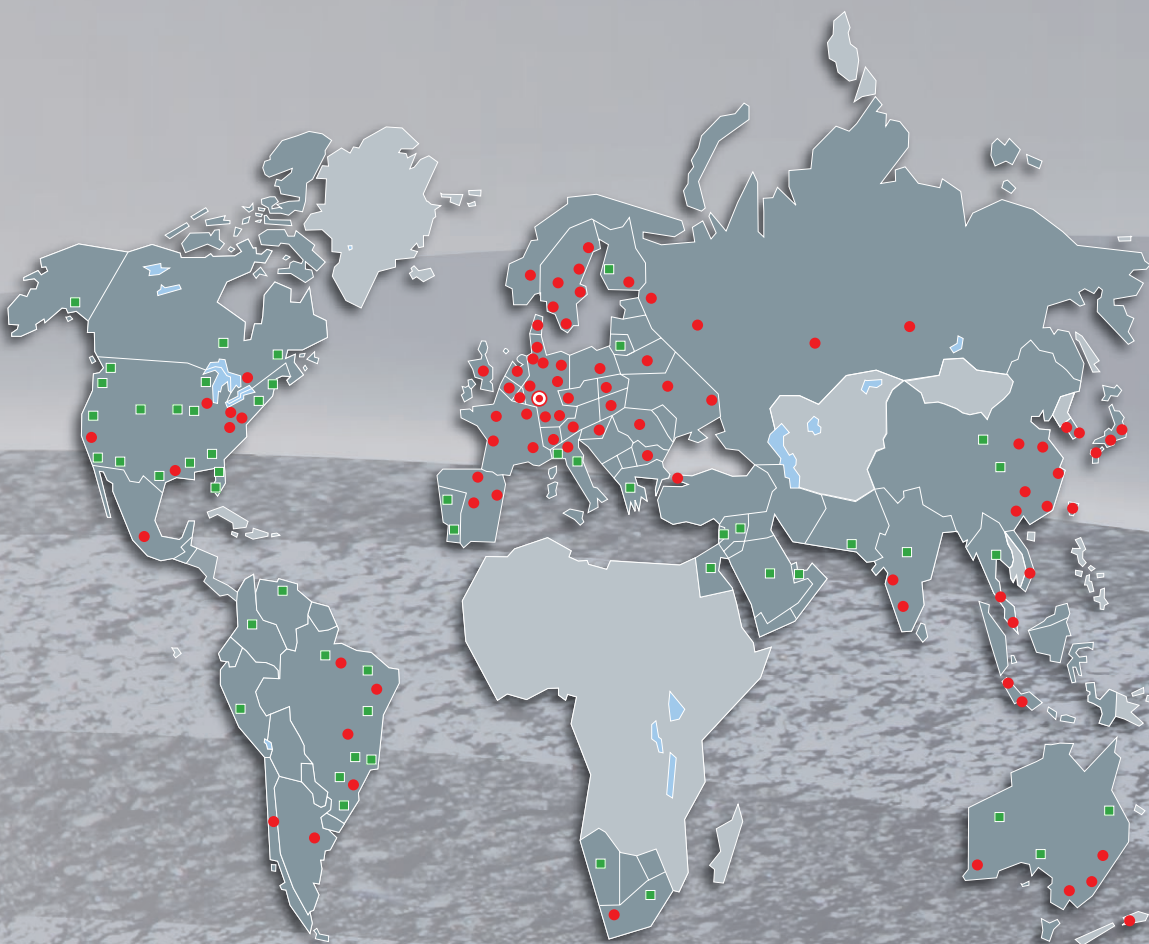

Cooling Systems 5,700

Global Presence. Local Expertise. www.hydac.com



-  HYDAC Headquarters
-  HYDAC Companies
-  HYDAC Sales and Service Partners

HYDAC INTERNATIONAL

**HYDAC FLUIDTECHNIK
GMBH**

Justus-von-Liebig-Straße
66280 Sulzbach/Saar
Germany

Tel.: +49 6897 509-01
Fax: +49 6897 509-577

E-mail: flutec@hydac.com
Internet: www.hydac.com