

Spare Parts List Return Line Filter RFB

Flow direction from in to out
up to 600 l/min, up to 10 bar

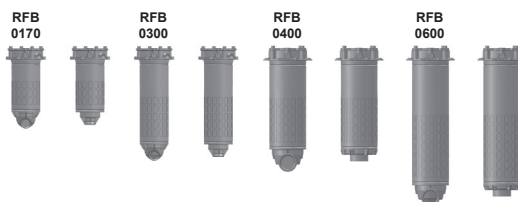

1. MAINTENANCE

1.1 GENERAL

Please follow the maintenance instructions!

1.2 INSTALLATION

The filters of type RFB are designed for tank mounting. Suitable connection flanges aligned for mounting must be present on the tank side.

The RFB filter is installed in the tank from above and fastened with screws of the machine manufacturer (M10), with attention given to the alignment of the interface in the filter base.

The filter is connected to the hydraulic return line via a plug-in tube connector. Please observe the removal height of the filter element.

Observe the name plate of the filter!

1.3 COMMISSIONING

Check that the correct filter element is fitted. Place the cover and tighten cover bolts alternately. Switch on hydraulic system and vent filter at a suitable point in the system. Check the filter for leakage.

1.4 TOOLS REQUIRED FOR MAINTENANCE

RFB	Torque value	Key Int. hex.
0170, 0300	20 Nm	SW 8
0400, 0600	25 Nm	SW 8

1.5 TORQUE VALUES FOR CLOGGING INDICATORS

Type	Max. torque
0170, 0300 0400, 0600	33 Nm

2. CHANGING THE ELEMENT

2.1 REMOVING THE ELEMENT

1. Switch off hydraulic system and release filter pressure (if necessary, release the pressure in the tank).
2. Loosen the cover screws and remove the cover.
3. Pull the filter element from the filter housing and let the residual oil drip into the filter housing.
4. Examine element surface for dirt residues and larger particles since these can be an indication of damage to components.
5. Exchange filter element.
6. Clean cover with bypass valve plug.
7. Examine filter, especially sealing surfaces, for mechanical damage.
8. Check seals – and replace if necessary.

2.2 FITTING THE ELEMENT

1. Lubricate the sealing surfaces on the filter housing and cover, as well as the moulded seal, with clean operating fluid.
2. When fitting a new filter element, check that the designation corresponds to that of the old element.
3. Insert the filter element into the filter housing and press into the seal seat.
4. Put on the cover, paying attention to the alignment for holding the clogging indicator. Press the cover down against the bypass spring and unscrew nuts by hand. Then tighten alternately and observe the torques specified by the machine manufacturer.
5. If necessary, refill hydraulic oil.
6. Switch on hydraulic system and vent filter at a suitable point in the system.
7. Check the filter for leakage.

NOTICE:

Filter elements which cannot be cleaned must be disposed of in accordance with environmental protection regulations.

3. SPARE PARTS

3.1 SPARE PARTS DRAWING RFB 0170, 0300

Housing connection H

Housing connection V

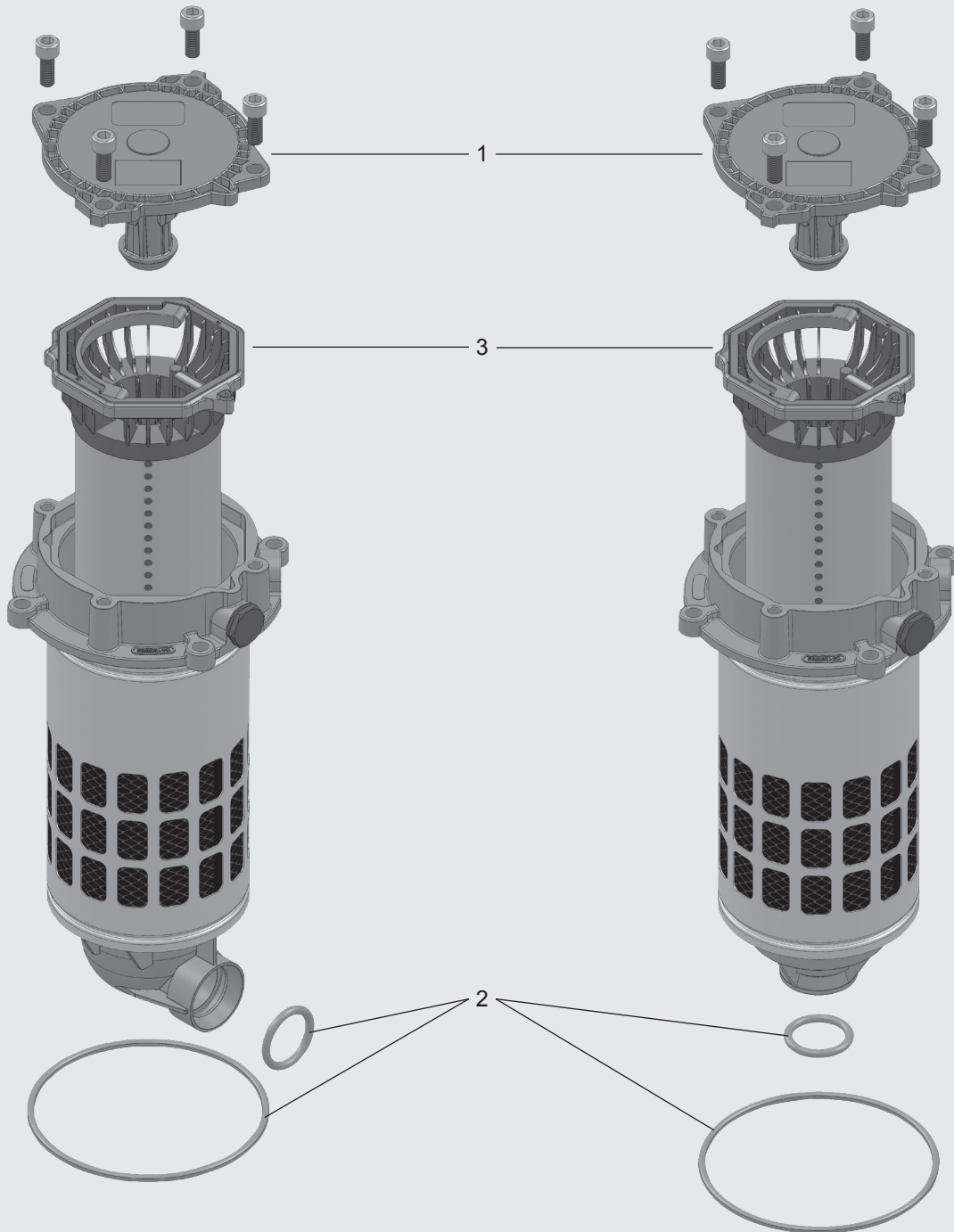

3.2 SPARE PARTS LIST RFB 0170, 0300 (specified in NBR seals)

Item	RFB 0170	RFB 0300
1.	Cover RFB 0170 – 0300 (part no.: 200127)	
2.	Seal kit RFB 0170 – 0300 (part no.: 200128) Housing: O-ring 148.59x-5.33-N-NBR-70Sh O-ring 35x3.5-NBR-70Sh	
3.	Filter element ULP-00xx-101-X512-S-N-RT UMC-00xx-101-X512-S-N-RT	Filter element ULP-00xx-101-X518-S-N-RT UMC-00xx-101-X518-S-N-RT
xx = filtration rating		

For special FKM seal design, please contact our sales!

3.3 SPARE PARTS DRAWING RFB 0400, 0600

Housing connection H

Housing connection V

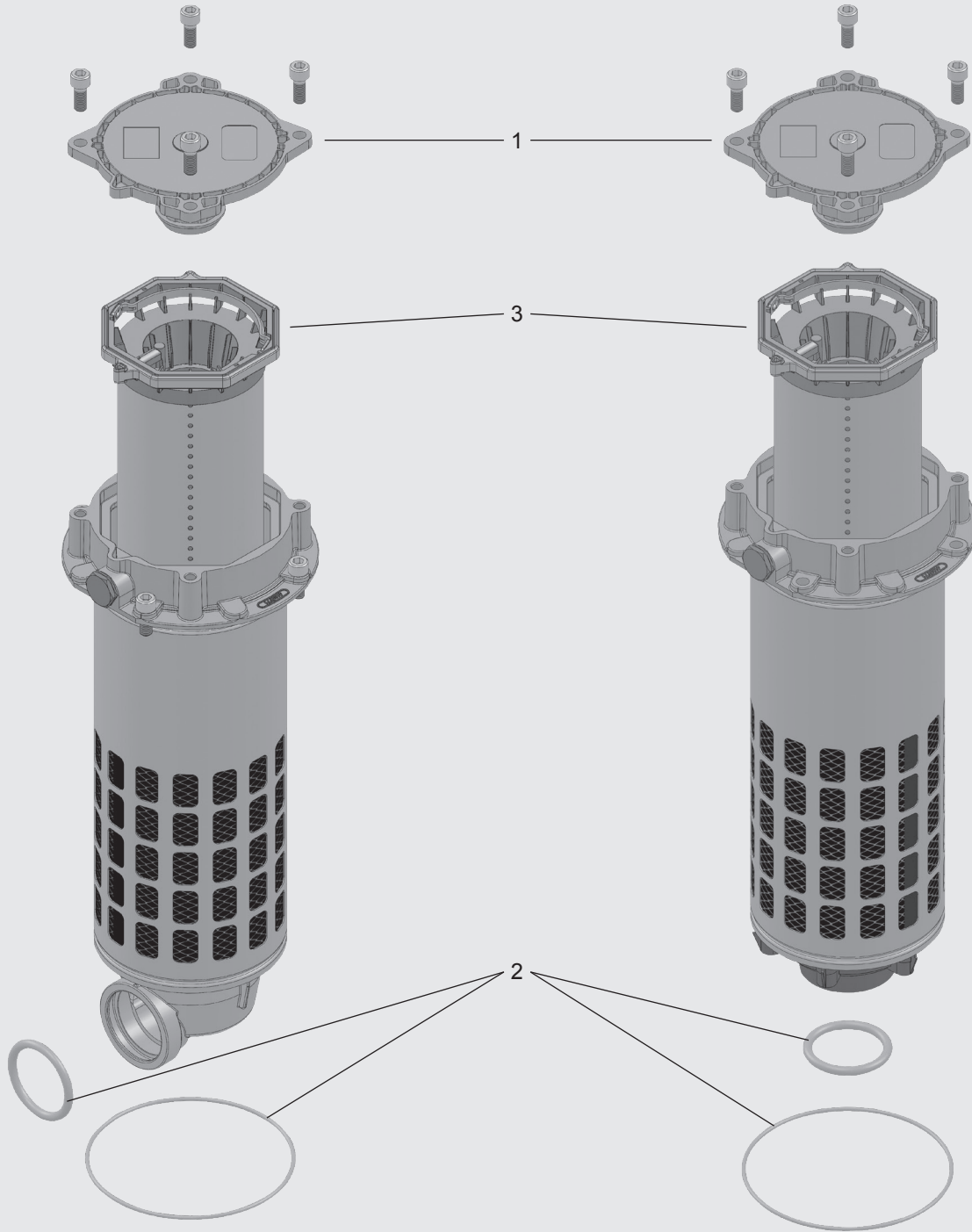

3.4 SPARE PARTS LIST RFB 0400, 0600 (specified in NBR seals)

Item	RFB 0400	RFB 0600
1.	Cover RFB 0400 – 0600 (part no.: 200129)	
2.	Seal kit RFB 0400 – 0600 Housing connection H and V (part no. 200131) O-ring 161x3.5-NBR-70Sh O-ring 56x7.5-NBR-70Sh	
3.	Filter element ULP-00xx-121-X517-S-N-RT UMC-00xx-121-X517-S-N-RT	Filter element ULP-00xx-121-X523-S-N-RT UMC-00xx-121-X523-S-N-RT
xx = filtration rating		

For special FKM seal design, please contact our sales!

4. MAINTENANCE INSTRUCTIONS

4.1 USER INSTRUCTIONS FOR FILTERS



Notice

This pressure equipment must only be put into operation in conjunction with a machine or system.



Notice

The pressure equipment must only be used as stipulated in the operating instructions of the machine or system.



Notice

This pressure equipment must only be operated using hydraulic or lubricating fluid.



Caution

The user must take appropriate action (e.g. air venting) to prevent the formation of air pockets.



Caution

Repair, maintenance work and commissioning must be carried out by specialist personnel only.

Allow the pressure equipment to cool before handling.

The stipulations of the operating instructions of the machine or system must be followed.



Danger

Caution: pressure equipment! Before any work is carried out on the pressure equipment, ensure the pressure chamber concerned (filter housing) is depressurised.



Danger

On no account may any modifications (welding, drilling, opening by force, etc.) be carried out on the pressure equipment.



Notice

It is the responsibility of the operator to comply with the water regulations of the country concerned.



Caution

Statutory accident prevention regulations, safety regulations and safety data sheets for fluids must be observed.



Caution

Filter housing must be earthed.



Caution

When working on, or in the vicinity of, hydraulic systems, naked flames, spark generation and smoking are forbidden.



Caution

Hydraulic oils and water-polluting fluids must not be allowed to enter the soil or watercourses or sewer systems.

Please ensure safe and environmentally friendly disposal of hydraulic oils. The relevant regulations in the country concerned with regard to ground water pollution, used oil and waste must be complied with.



Caution

Whenever work is carried out on the filter, be prepared for hot oil to escape which can cause injury or scalding as a result of its high pressure or temperature.



Danger

When using electrical clogging indicators, the electrical power supply to the system must be switched off before removing the clogging indicator connector.



Caution

Filters with switching valve are designed to have a permissible leakage depending on the operating medium. This is independent of the operating medium.

Customer Information in respect of Machinery Directive 2006/42/EC

Hydraulic filters are fluid power parts/ components and are therefore excluded from the scope of the Machinery Directive. They will not bear the CE mark! Before using these components, ensure compliance with the specifications provided by HYDAC Filtertechnik GmbH in this documentation.

The specifications also contain information on the relevant essential health and safety requirements (based on Machinery Directive 2006/42/EC) that are to be applied by the user.

We hereby declare that the filters are intended to be incorporated into machinery within the terms of the Machinery Directive 2006/42/EC.

It is prohibited to put the filters into service until the machinery as a whole is in conformity with the provisions of the Machinery Directive.

Furthermore, our Terms of Sale and Delivery are available on our website (www.hydac.de).

SERVICE ADDRESSES

HYDAC Filtertechnik GmbH
Industriegebiet
D-66280 Sulzbach/Saar
Tel.: 0 68 97 / 509-01
Fax: 0 68 97 / 509-300
Internet: www.hydac.com
E-mail: filter@hydac.com

6.2 MAINTENANCE, GENERAL

This section describes maintenance work which must be carried out periodically. The operational safety and life expectancy of the filter, and whether it is ready for use, depend to a large extent on regular and careful maintenance.

6.3 MAINTENANCE MEASURES

- Spare parts must fulfil the technical requirements specified by the manufacturer. This is always ensured when using original HYDAC spare parts.
- Keep tools, working area and equipment clean.
- After disassembling the filter, clean all parts, check for damage or wear and replace parts if necessary.
- When changing a filter element, a high level of cleanliness must be observed!

6.4 INTERVAL BETWEEN ELEMENT CHANGES

We generally recommend changing the filter elements at the latest after an operating time of 1 year. When no clogging indicator has been fitted, we recommend changing the elements at specific intervals (the frequency of changing the filter elements depends on the filter design and the conditions under which the filter is operated). When filter elements are subject to high dynamic loading it may prove necessary to change them more frequently. The same applies when the hydraulic system is commissioned or repaired or when the oil is changed. Standard clogging indicators only take effect when the filter is subject to flow. With electrical indicators the signal can also be converted into a continuous display on the control panel. In this case the continuous display must be switched off during a cold start or after changing the element. If the clogging indicator responds during a cold start only, it is possible that the element does not yet need to be changed.

NOTICE

The information in this brochure relates to the operating conditions and applications described. For applications or operating conditions not described, please contact the relevant technical department. All technical details are subject to change.