

Mobile Technology Priority Valve for Mobile Hydraulics MPV...

DESCRIPTION

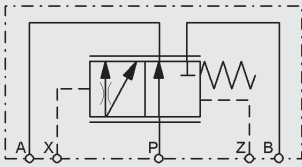

1. DESCRIPTION

1.1. APPLICATIONS

In mobile hydraulics, for example:
Priority supply of a closed centre steering system

1.2. GENERAL

- The priority valve MPV for flange-mounting is used where one hydraulic function is to have a priority supply over another.
- When the priority function is operated, the required fluid volume is diverted from the pump flow.
- The remaining oil flow is fed to other functions.



2. TECHNICAL SPECIFICATIONS

2.1. GENERAL DATA

2.1.1 Weight

approx. 1.6 Kg

2.1.2 Construction / Operation

Flange connection, hydraulically operated

2.2. HYDRAULIC DATA

2.2.1 Max. pressure

$p_{\max} = 250 \text{ bar}$

2.2.2 Max. flow rate

$Q_{\max} = 60 \text{ l/min}$

2.2.3. Max. pressure drop

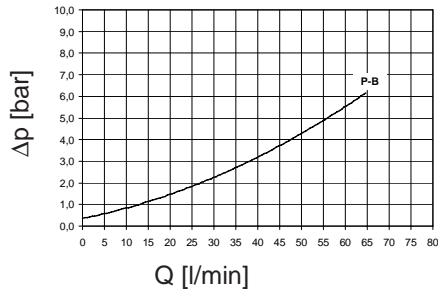

measured using MPV-10-F-10-011

2.2.4 Operating fluid

Mineral oil to DIN 51524

2.2.5. Viscosity range

2.8mm²/s - 380mm²/s

2.2.6. Seal material

NBR or FPM
(depending on the model)

2.2.7. Filtration:

Max. permissible cleanliness class of the operating fluid to NAS 1638 Class 9

2.2.8. Ambient temperature range

- 20°C - +80°C

2.2.9 Oil temperature range

- 20°C - +80°C

FUNCTION

Example circuit:

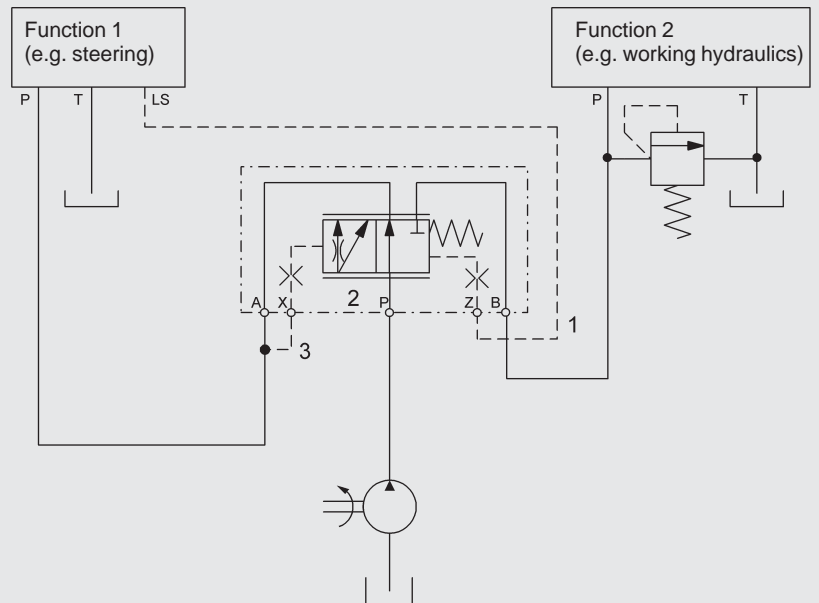

Functions 1 and 2 are supplied by a fixed delivery pump. Function 1 has the priority in this case.

1st condition:

Function 1 requires less flow than the fixed delivery pump supplies.

In the initial state, port P of the priority valve is connected to outlet A. The oil flow supplies function 1. The pressure at P of function 1 is transferred to port X of the priority valve via control line 3.

The control pressure LS of function 1 is fed to the opposite side of the spool via port Z. In addition to the control pressure, the spring also acts on the opposite side.

If function 1 does not require any oil, the pressure increases at ports P and X. If the pressure at port X is greater than the sum of the control pressure at port Z and the spring force, the spool switches over and port P of the priority valve is connected to outlet B.

The oil then flows to function 2.

2nd condition:

Function 1 suddenly requires full flow from the fixed delivery pump.

Function 1 requires oil and the pressure in port P of function 1 decreases.

If the sum of the control pressure in port Z of the priority valve and the spring force is greater than the pressure at port X, the spool switches back.

Port P of the priority valve is connected to outlet A.

3. MODEL CODE

(also ordering example)

MPV 10- F- 10 - XXX - XXX

Priority valve for mobile

Nominal size

Mounting type

F = flange housing

Control pressure of the spring

10 = 10 bar

Type

Spool / Control

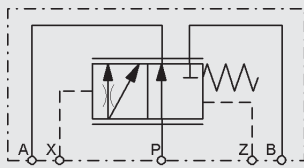

Type 11X

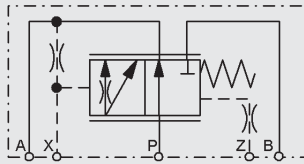

Type 02X

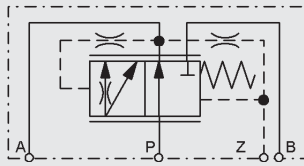

Type 03X

Series

(determined by manufacturer)

Other types available on request

4. DIMENSIONS

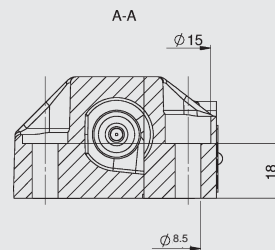
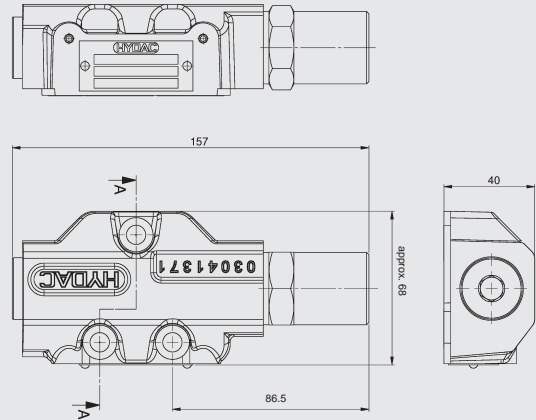

Required surface finish of the mounting surface

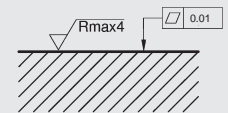

Required interface of the mounting surface

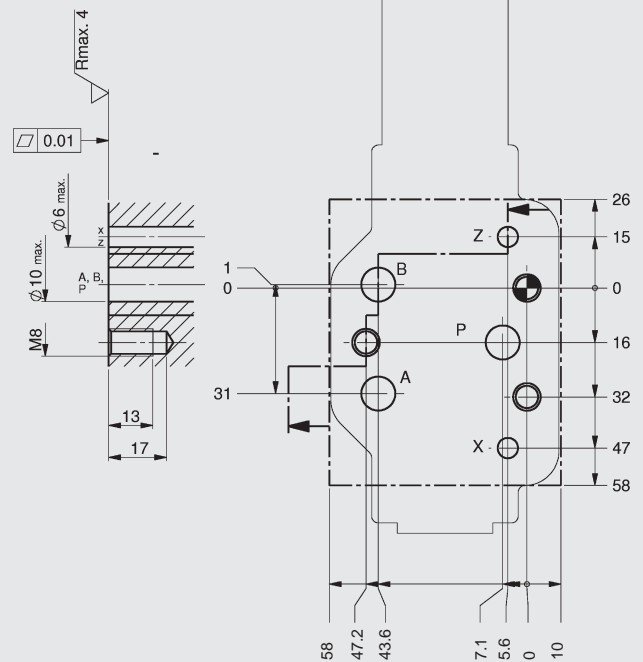

NOTE

The information in this brochure relates to the operating conditions and applications described. For applications or operating conditions not described, please contact the relevant technical department. Subject to technical modifications.