

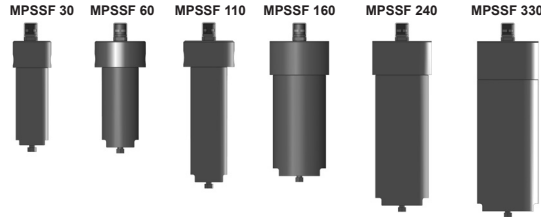

## Spare Parts List Inline Filter MPSSF and Filter for Manifold Mounting MPSSF...P up to 130 l/min, up to 450 bar



### 1. MAINTENANCE

#### 1.1 GENERAL

Please follow the maintenance instructions!



Notice

**Further information is provided in the operating and maintenance manual 3434289 included with**

**delivery.**

#### 1.2 INSTALLATION

Before fitting the filter into the system, check that the operating pressure of the system does not exceed the permitted operating pressure of the filter.

Refer to the name plate on the filter!

##### Important:

When using filters without bypass valve and at operating pressures above 20 bar, robust filter elements of the type BH/HC must be used for safety reasons.

Under extreme conditions (e.g. cold start), bypass valves will allow a partial flow past the element for a short time.

#### 1.3 COMMISSIONING

Check that the correct filter element is fitted. Screw in bowl again fully and then unscrew by one quarter-turn (the sealing effect will not be improved by overtightening).

Switch on the hydraulic system and check filter for leakage.

Vent filter at an appropriate point in the system.

#### 1.4 TOOLS REQUIRED FOR MAINTENANCE

Generally use strap wrench for filter bowl!

Size	Key for oil drain plug	Torque value
30, 60, 110, 160, 240	AF width 16	24 Nm

Size	Spanner for bypass screw	Torque value
60, 110	AF width 6	30 Nm
160, 240	AF width 10	80 Nm

#### 1.5 TORQUE VALUE FOR CLOGGING INDICATORS

Type	Max. torque
VD	100 Nm

### 2. CHANGING THE ELEMENT

#### 2.1 REMOVING THE ELEMENT

Before removing the element, it must be ensured that the filter is not installed in a potentially explosive location (gases, vapours, mists, etc.)

1. Switch off hydraulic system and release filter pressure.
2. Remove oil drain plug on the bowl and drain fluid into a suitable container and clean or dispose of it in accordance with environmental regulations.
3. Unscrew filter bowl.
4. Remove filter element from element spigot in filter head (check surface of element for contamination residue and larger particles; these can indicate damage to components).
5. Replace or clean filter element (only W/HC, D and M elements can be cleaned).
6. Clean filter bowl and filter head; particular attention must be given to the threads!
7. Examine filter, especially sealing surfaces, for mechanical damage.
8. Check O-rings – and replace if necessary

#### 2.2 FITTING THE ELEMENT

1. Lubricate the sealing surfaces on the filter housing and cover, as well as the O-ring, with clean operating fluid.
2. When fitting a new filter element, check that the designation corresponds to that of the old element. Then lubricate O-ring in the element with clean operating fluid.
3. Place filter element carefully onto the element spigot in the housing.
4. Screw in filter bowl fully.
5. Screw in oil drain plug.
6. Unscrew filter bowl by one quarter-turn.
7. Switch on hydraulic system and vent filter at a suitable point in the system.
8. Check the filter for leakage.

#### NOTICE:

Contamination or incomplete pressure release on disassembly can lead to seizing of the bowl thread.

Filter elements which cannot be cleaned must be disposed of in accordance with environmental protection regulations.

### 3. SPARE PARTS

#### 3.1 SPARE PARTS DRAWING MPSSF

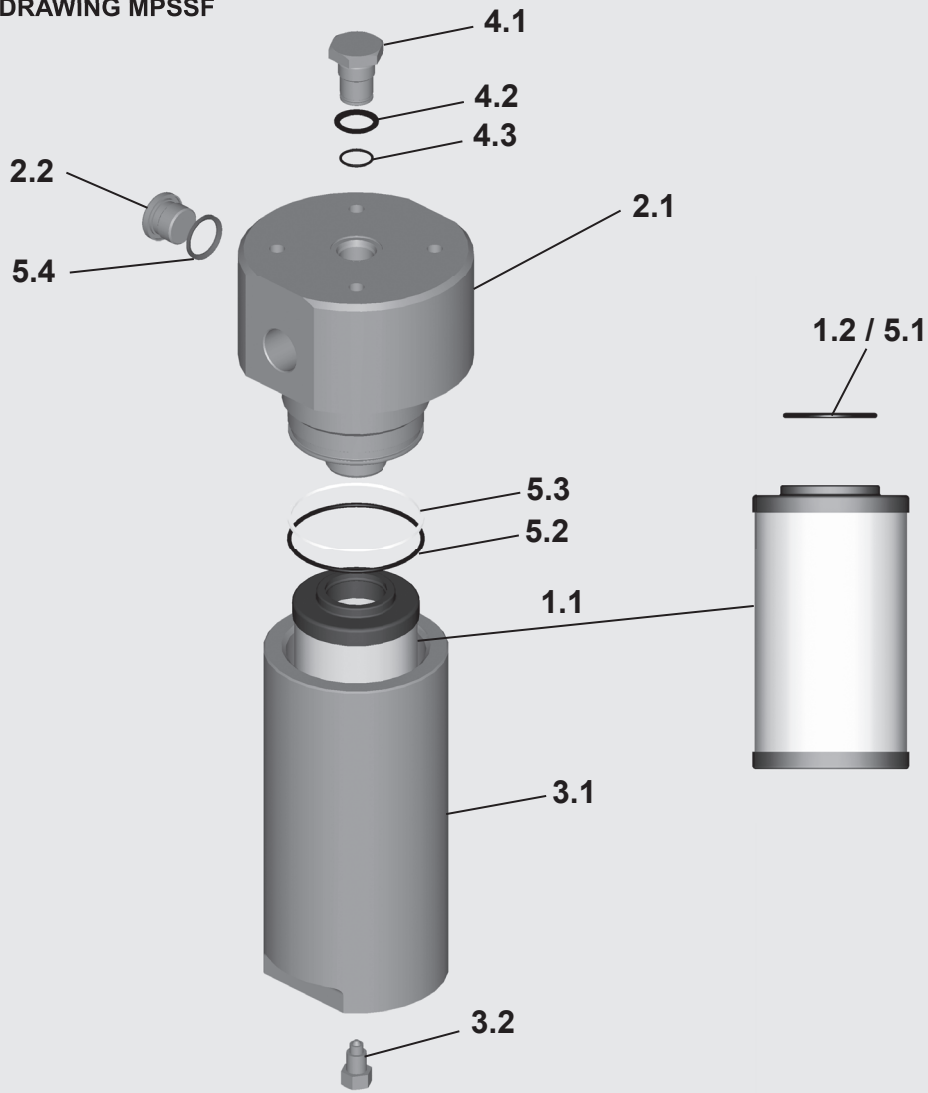

#### 3.2 SPARE PARTS LIST MPSSF

Item	Consists	Description	MPSSF 30	MPSSF 60 / 110	MPSSF 160 / 240	MPSSF 330
<b>1.</b>		<b>Filter element</b>	see Point 4. Replacement elements			
	1.1	Filter element	0030 D...	0060 D... / 0110 D...	0160 D... / 0240 D...	0330 D...
	1.2	O-ring	12.37 x 2.62	22 x 3	34 x 3	48 x 3
<b>2.</b>		<b>Filter head</b>	See brochure MPSSF (7.580../..)			
	2.1	Filter head	Connections as ordered			
	2.2	Bypass screw	Only present if bypass function was ordered			
<b>3.</b>		<b>Filter bowl</b>	See brochure HPSSF (7.580../..)			
	3.1	Filter bowl	model-specific			
	3.2	Oil drain/air bleed screw	7/16" UNF			
<b>4.</b>		<b>Clogging indicator or screw plug</b>	See Point 5. Replacement clogging indicator			
	4.1	Screw plug VDHP 0 A.0 VDHP 0 A.0 /-V	3341590 1200095148			
	4.2	Profile seal ring	VD...			
	4.3	O-ring	15 x 1.5			
<b>5.</b>		<b>Seal kit E MPSSF</b>	3540021	3181768	1200094681	3422721
		<b>Seal kit E MPSSF /-V</b>	1200099410	1200094612	1200094682	3422718
	5.1	O-ring (element)	12.73 x 2.62	22 x 3	34 x 3	48 x 3
	5.2	O-ring (filter head)	34.59 x 2.62	47 x 3	69.6 x 2.4	85.09 x 5.33
	5.3	Back-up ring (filter head)	40 x 36.3 x 2	52 x 47.3 x 2	70.15 x 74 x 2	86.5 x 95 x 2
	5.4	Seal ring (bypass screw)	-	G ¼	G ½	-

Other spare parts on request!

## 4. REPLACEMENT ELEMENT

### 4.1 STANDARD

**0060 D 003 BN4HC /-V-SS-SO361**

#### Size

0030, 0060, 0110, 0160,  
0240, 0330

#### Type

D

#### Filtration rating

ON: 001, 003, 005, 010, 015, 020

BH4HC: 003, 005, 010, 020

BN4HC, BH4HC: 003, 010

(/-SS-SO361)

W/HC: 025, 050, 100, 200

#### Filter material

ON, BN4HC, BH4HC, W/HC

#### Supplementary details

SS-SO361      stainl. steel core and end caps,  
polyamide support fibre  
V, N, NLT, HNBR, EPDM, K  
(for description see "MPSSF" brochure)

### 4.2 PROCESS TECHNOLOGY

**060 - DH - 100 - D - V**

#### Size

030, 060, 110, 160, 240, 330

#### Type

DH

#### Filtration rating

Chemicon® (M): 001, 003, 005, 010, 020

Wire mesh (D): 025, 040, 060, 100, 150, 200, 250

#### Filter material

M, D

#### Supplementary details

V, N, NLT, HNBR, EPDM, K  
(for description see "MPSSF" brochure)

## 5. REPLACEMENT CLOGGING INDICATOR

**VD 5 D X /-L24**

#### Type of indicator

VD    differential pressure indicator

#### Response pressure

5     standard 5 bar, others on request

#### Type of clogging indicator

A     with screw plug in indicator port

B     visual

C     electrical

D     visual and electrical

#### Modification number

X     the latest version is always supplied

#### Supplementary details

L, ... LED, V, W  
(for description, see "Clogging Indicators" brochure)

## 6. MAINTENANCE INSTRUCTIONS

### 6.1 USER INSTRUCTIONS FOR FILTERS



Notice

This pressure equipment must only be put into operation in conjunction with a machine or system.



Notice

The pressure equipment must only be used as stipulated in the operating instructions of the machine or system.



Notice

This pressure equipment must only be operated using hydraulic or lubricating fluid.



Caution

The user must take appropriate action (e.g. venting) to prevent the formation of air pockets.



Caution

Repair, maintenance work and commissioning must be carried out by specialist personnel only.

Allow the pressure equipment to cool before handling.

The stipulations of the operating instructions of the machine or system must be followed.



Danger

**Caution: pressure equipment! Before any work is carried out on the pressure equipment, ensure the pressure chamber concerned (filter housing) is depressurised.**



Danger

On no account must any modifications (welding, drilling, opening by force etc.) be carried out on the pressure equipment.



Notice

It is the responsibility of the owner to comply with the water regulations of the country concerned.



Caution

Statutory accident prevention regulations, safety regulations and safety data sheets for fluids must be observed.



Caution

Filter housing must be earthed.



Caution

When working on, or in the vicinity of, hydraulic systems, naked flames, spark generation and smoking are forbidden.



Caution

Hydraulic oils and water-polluting fluids must not be allowed to enter the soil or watercourses or sewer systems. Please ensure safe and environmentally friendly disposal of hydraulic oils. The relevant regulations in the country concerned with regard to ground water pollution, used oil and waste must be complied with.



Caution

Whenever work is carried out on the filter, be prepared for hot oil to escape which can cause injury or scalding as a result of its high pressure or temperature.



Danger

When using electrical clogging indicators, the electrical power supply to the system must be switched off before removing the clogging indicator connector.

### Customer Information in respect of Machinery Directive 2006/42/EC

Hydraulic filters are fluid power parts/ components and are therefore excluded from the scope of the Machinery Directive. They do not bear the CE mark. Before using these components, ensure compliance with the specifications provided by HYDAC Filtertechnik GmbH in this documentation.

The specifications also contain information on the relevant essential health and safety requirements (based on Machinery Directive 2006/42/EC) that are to be applied by the user.

We hereby declare that the filters are intended to be incorporated into machinery within the terms of the Machinery Directive 2006/42/EC.

It is prohibited to put the filters into service until the machinery as a whole is in conformity with the provisions of the Machinery Directive. Furthermore, our Terms of Sale and Delivery are available on our website ([www.hydac.com](http://www.hydac.com)).

### SERVICE ADDRESSES

**HYDAC Service GmbH**  
Postfach 1251  
66273 Sulzbach / Saar, Germany

#### Factory address:

Werk 13  
Friedrichsthaler Str. 15  
66540 Neunkirchen / Heinitz  
Germany

#### ServiCenter:

Tel.: +49 (0) 6897 / 509-9083  
Fax: +49 (0) 6897 / 509-9881

#### Customer service:

Tel: +49 (0) 6897 / 509-412  
Fax: +49 (0) 6897 / 509-828

### 6.2 MAINTENANCE, GENERAL

This section describes maintenance work which must be carried out periodically. The operational safety and life expectancy of the filter, and whether it is ready for use, depend to a large extent on regular and careful maintenance.

### 6.3 MAINTENANCE MEASURES

- Spare parts must fulfil the technical requirements specified by the manufacturer. This is always ensured when using original HYDAC spare parts.
- Keep tools, working area and equipment clean.
- After disassembling the filter, clean all parts, check for damage or wear and replace parts if necessary.
- When changing a filter element, a high level of cleanliness must be observed!

### 6.4 INTERVAL BETWEEN ELEMENT CHANGES

In principle we recommend that the filter element is changed after 1 year of operation at the latest.

We recommend installing the filter with a clogging indicator (visual and/or electrical or electronic) to monitor the filter element.

If the clogging indicator responds, it is necessary to change or clean the filter element without delay (only W and V elements can be cleaned).

When no clogging indicator has been fitted, we recommend changing the elements at specific intervals. (The frequency of changing the filter elements depends on the filter design and the conditions under which the filter is operated.) When filter elements are subject to high dynamic loading it may prove necessary to change them more frequently. The same applies when the hydraulic system is commissioned or repaired or when the oil is changed.

The standard clogging indicators only respond when fluid is flowing through the filter. With electrical indicators the signal can also be converted into a continuous display on the control panel. In this case the continuous display must be switched off during a cold start or after changing the element.

If the clogging indicator responds during a cold start only, it is possible that the element does not yet need to be changed.

### NOTE

The information in this brochure relates to the operating conditions and applications described. For applications and operating conditions not described, please contact the relevant technical department. Subject to technical modifications.

**NOTES**

A large grid of graph paper for taking notes, consisting of 20 columns and 30 rows of small squares.