

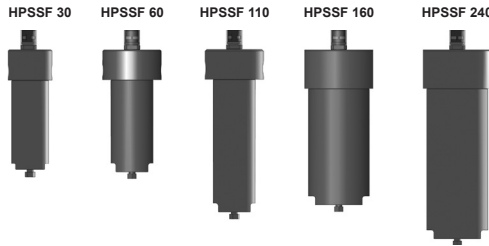

Spare Parts List Inline Filter HPSSF up to 130 l/min, up to 700 bar



1. MAINTENANCE

1.1 GENERAL

Please follow the maintenance instructions!



Notice

Further information is provided in the operating and maintenance manual 3423882 included with delivery.

1.2 INSTALLATION

Before fitting the filter into the system, check that the operating pressure of the system does not exceed the permitted operating pressure of the filter.

Refer to the name plate on the filter!

Important:

When using filters without bypass valve and at operating pressures above 20 bar, robust filter elements of the type BH/HC must be used for safety reasons.

Under extreme conditions (e.g. cold start), bypass valves will allow a partial flow past the element for a short time.

1.3 COMMISSIONING

Check that the correct filter element is fitted. Screw in bowl again fully and then unscrew by one quarter-turn (the sealing effect will not be improved by overtightening).

Switch on the hydraulic system and check filter for leakage.

Vent filter at an appropriate point in the system.

1.4 TOOLS REQUIRED FOR MAINTENANCE

Generally use strap wrench for filter bowl!

Size	Key for oil drain plug	Torque value
30, 60, 110, 160, 240	AF width 16	24 Nm

1.5 TORQUE VALUE FOR CLOGGING INDICATORS

Type	Max. torque
VD	100 Nm

2. CHANGING THE ELEMENT

2.1 REMOVING THE ELEMENT

Before removing the element, it must be ensured that the filter is not installed in a potentially explosive location (gases, vapours, mists, etc.)

1. Switch off hydraulic system and release filter pressure.
2. Remove oil drain plug on the bowl and drain fluid into a suitable container and clean or dispose of it in accordance with environmental regulations.
3. Unscrew filter bowl.
4. Remove filter element from element spigot in filter head (check surface of element for contamination residue and larger particles; these can indicate damage to components).
5. Replace or clean filter element (only W/HC, D and M elements can be cleaned).
6. Clean filter bowl and filter head; particular attention must be given to the threads!
7. Examine filter, especially sealing surfaces, for mechanical damage.
8. Check O-rings – and replace if necessary

2.2 FITTING THE ELEMENT

1. Lubricate the sealing surfaces on the filter housing and cover, as well as the O-ring, with clean operating fluid.
2. When fitting a new filter element, check that the designation corresponds to that of the old element. Then lubricate O-ring in the element with clean operating fluid.
3. Place filter element carefully onto the element spigot in the housing.
4. Screw in filter bowl fully.
5. Screw in oil drain plug.
6. Unscrew filter bowl by one quarter-turn.
7. Switch on hydraulic system and vent filter at a suitable point in the system.
8. Check the filter for leakage.

NOTICE:

Contamination or incomplete pressure release on disassembly can lead to seizing of the bowl thread.

Filter elements which cannot be cleaned must be disposed of in accordance with environmental protection regulations.

3. SPARE PARTS

3.1 SPARE PARTS DRAWING HPSSF

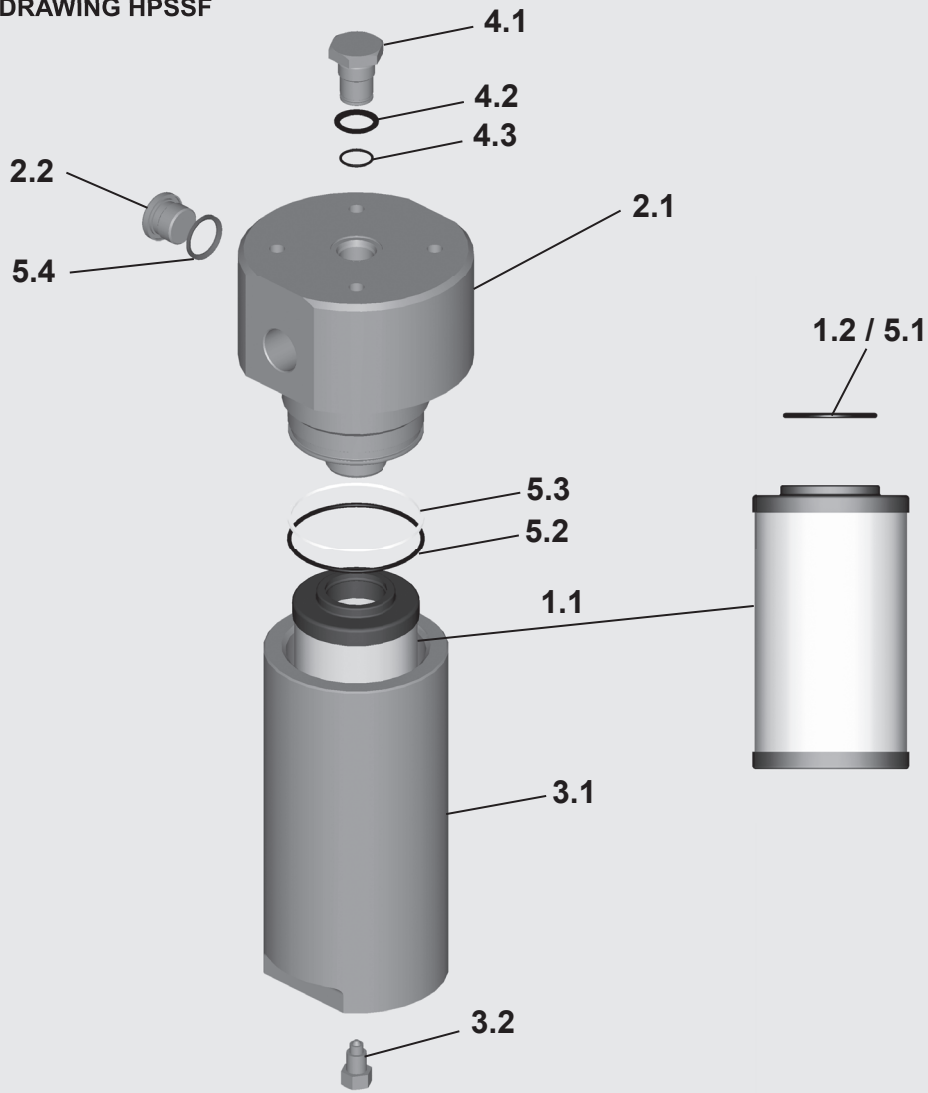

3.2 SPARE PARTS LIST HPSSF

Item	Consists	Description	HPSSF 30	HPSSF 60 / 110	HPSSF 160 / 240
1.		Filter element	see Point 4. Replacement elements		
	1.1	Filter element	0030 D...	0060 D... / 0110 D...	0160 D... / 0240 D...
	1.2	O-ring	12.37 x 2.62	22 x 3	34 x 3
2.		Filter head	See brochure HPSSF (7.579../...)		
	2.1	Filter head	Connections as ordered		
	2.2	Bypass screw	Only present if bypass function was ordered		
3.		Filter bowl	See brochure HPSSF (7.579../...)		
	3.1	Filter bowl	model-specific		
	3.2	Oil drain/air bleed screw	7/16" UNF		
4.		Clogging indicator or screw plug	See Point 5. Replacement clogging indicator		
	4.1	Screw plug VDHP 0 A.0 VDHP 0 A.0 /-V	3423880 1200099338		
	4.2	O-ring	16 x 2.5		
	4.3	O-ring	14 x 1.5		
5.		Seal kit E HPSSF Seal kit E HPSSF /-V	3540021 1200099410	3181768 1200094612	1200094681 1200094682
	5.1	O-ring (element)	12.73 x 2.62	22 x 3	34 x 3
	5.2	O-ring (filter head)	34.59 x 2.62	47 x 3	69.6 x 2.4
	5.3	Back-up ring (filter head)	40 x 36.3 x 2	52 x 47.3 x 2	74 x 70.15 x 2
	5.4	Seal ring (bypass screw)	-	G¼	G½

Other spare parts on request!

4. REPLACEMENT ELEMENT

4.1 STANDARD

0060 D 003 BN4HC /-V-SS-SO361

Size
0030, 0060, 0110, 0160, 0240

Type
D

Filtration rating
ON 001, 003, 005, 010, 015, 020
BH4HC 003, 005, 010, 020
BN4HC, BH4HC: 003, 010
(/-SS-SO361)
W/HC: 025, 050, 100, 200

Filter material
ON, BN4HC, BH4HC, W/HC

Supplementary details
SS-SO361 stainl. steel core and end caps, polyamide support fibre
V, N, NLT, HNBR, EPDM, K
(for description see "HPSSF" brochure)

4.2 PROCESS TECHNOLOGY

060 - DH - 100 - D - V

Size
030, 060, 110, 160, 240

Type
DH

Filtration rating
Chemicon® (M): 001, 003, 005, 010, 020
Wire mesh (D): 025, 040, 060, 100, 150, 200, 250

Filter material
M, D

Supplementary details
V, N, NLT, HNBR, EPDM, K
(for description see "HPSSF" brochure)

5. REPLACEMENT CLOGGING INDICATOR

VDHP 5 D X /-L24

Type of indicator
VDHP Differential pressure indicator up to 700 bar operating pressure

Response pressure
5 standard 5 bar, others on request

Type of clogging indicator
A with screw plug in indicator port
B visual
C electrical
D visual and electrical

Modification number
X the latest version is always supplied

Supplementary details
L..., LED, V, W
(for description, see "Clogging Indicators" brochure)

6. MAINTENANCE INSTRUCTIONS

6.1 USER INSTRUCTIONS FOR FILTERS



Notice

This pressure equipment must only be put into operation in conjunction with a machine or system.



Notice

The pressure equipment must only be used as stipulated in the operating instructions of the machine or system.



Notice

This pressure equipment must only be operated using hydraulic or lubricating fluid.



Caution

The user must take appropriate action (e.g. venting) to prevent the formation of air pockets.



Caution

Repair, maintenance work and commissioning must be carried out by specialist personnel only.

Allow the pressure equipment to cool before handling.

The stipulations of the operating instructions of the machine or system must be followed.



Danger

Caution: pressure equipment! Before any work is carried out on the pressure equipment, ensure the pressure chamber concerned (filter housing) is depressurised.



Danger

On no account must any modifications (welding, drilling, opening by force etc.) be carried out on the pressure equipment.



Notice

It is the responsibility of the owner to comply with the water regulations of the country concerned.



Caution

Statutory accident prevention regulations, safety regulations and safety data sheets for fluids must be observed.



Caution

Filter housing must be earthed.



Caution

When working on, or in the vicinity of, hydraulic systems, naked flames, spark generation and smoking are forbidden.



Caution

Hydraulic oils and water-polluting fluids must not be allowed to enter the soil or watercourses or sewer systems. Please ensure safe and environmentally friendly disposal of hydraulic oils. The relevant regulations in the country concerned with regard to ground water pollution, used oil and waste must be complied with.



Caution

Whenever work is carried out on the filter, be prepared for hot oil to escape which can cause injury or scalding as a result of its high pressure or temperature.



Danger

When using electrical clogging indicators, the electrical power supply to the system must be switched off before removing the clogging indicator connector.

Customer Information in respect of Machinery Directive 2006/42/EC

Hydraulic filters are fluid power parts/ components and are therefore excluded from the scope of the Machinery Directive. They do not bear the CE mark. Before using these components, ensure compliance with the specifications provided by HYDAC Filtertechnik GmbH in this documentation.

The specifications also contain information on the relevant essential health and safety requirements (based on Machinery Directive 2006/42/EC) that are to be applied by the user.

We hereby declare that the filters are intended to be incorporated into machinery within the terms of the Machinery Directive 2006/42/EC.

It is prohibited to put the filters into service until the machinery as a whole is in conformity with the provisions of the Machinery Directive. Furthermore, our Terms of Sale and Delivery are available on our website (www.hydac.com).

SERVICE ADDRESSES

HYDAC Service GmbH
Postfach 1251
66273 Sulzbach / Saar, Germany

Factory address:

Werk 13
Friedrichsthaler Str. 15
66540 Neunkirchen / Heinitz
Germany

ServiCenter:

Tel.: +49 (0) 6897 / 509-9083
Fax: +49 (0) 6897 / 509-9881

Customer service:

Tel: +49 (0) 6897 / 509-412
Fax: +49 (0) 6897 / 509-828

6.2 MAINTENANCE, GENERAL

This section describes maintenance work which must be carried out periodically. The operational safety and life expectancy of the filter, and whether it is ready for use, depend to a large extent on regular and careful maintenance.

6.3 MAINTENANCE MEASURES

- Spare parts must fulfil the technical requirements specified by the manufacturer. This is always ensured when using original HYDAC spare parts.
- Keep tools, working area and equipment clean.
- After disassembling the filter, clean all parts, check for damage or wear and replace parts if necessary.
- When changing a filter element, a high level of cleanliness must be observed!

6.4 INTERVAL BETWEEN ELEMENT CHANGES

In principle we recommend that the filter element is changed after 1 year of operation at the latest.

We recommend installing the filter with a clogging indicator (visual and/or electrical or electronic) to monitor the filter element.

If the clogging indicator responds, it is necessary to change or clean the filter element without delay (only W and V elements can be cleaned).

When no clogging indicator has been fitted, we recommend changing the elements at specific intervals. (The frequency of changing the filter elements depends on the filter design and the conditions under which the filter is operated.) When filter elements are subject to high dynamic loading it may prove necessary to change them more frequently. The same applies when the hydraulic system is commissioned or repaired or when the oil is changed.

The standard clogging indicators only respond when fluid is flowing through the filter. With electrical indicators the signal can also be converted into a continuous display on the control panel. In this case the continuous display must be switched off during a cold start or after changing the element.

If the clogging indicator responds during a cold start only, it is possible that the element does not yet need to be changed.

NOTE

The information in this brochure relates to the operating conditions and applications described. For applications and operating conditions not described, please contact the relevant technical department. Subject to technical modifications.

