

**X-Series**

**Installation and Operating Instructions**

Load-Sensing Sectional Control Valves

**LX-6 / LCX-6 / LX-3**

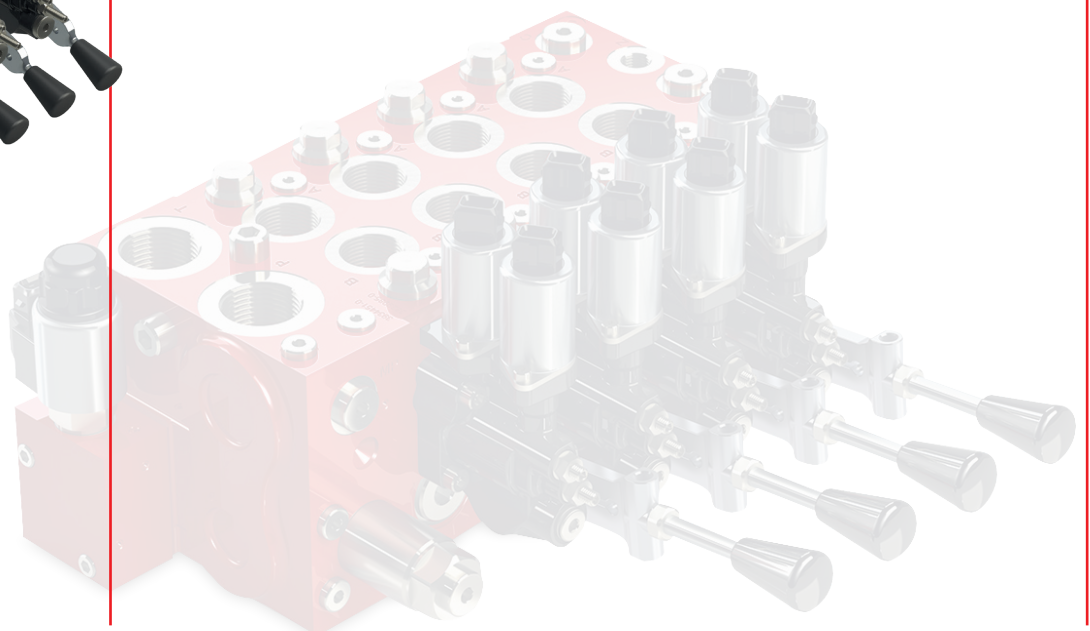
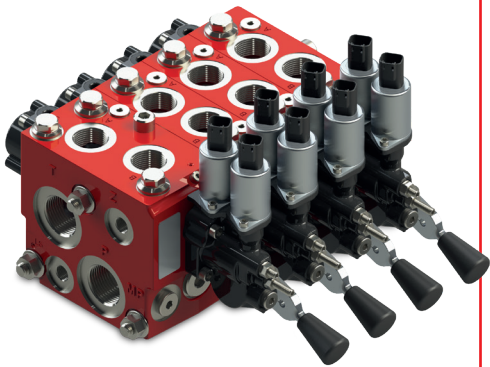
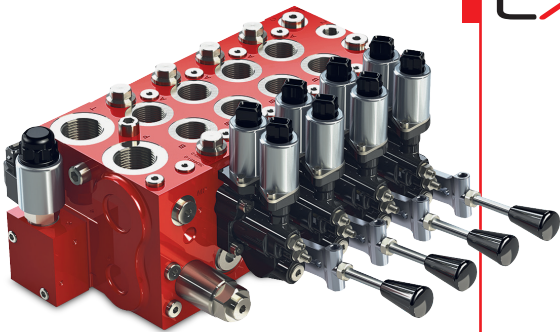

# Contents

## 1 General information

1.1	Purpose .....	1
1.2	Scope of application for the installation and operating instructions.....	1
1.3	Integration of the control valve into the hydraulic system.....	1
1.4	Manufacturers.....	2
1.5	Product description.....	2
1.6	Identifying the control valve.....	2
1.7	Other identification plates on the control valve .....	3
1.8	Customer service .....	3
1.9	Information about these installation and operating instructions .....	3
1.10	Other relevant documents .....	3
1.11	Storage .....	3
1.12	Key .....	4
1.13	Abbreviations.....	4
1.14	Exclusion of liability for these installation and operating instructions .....	4

## 2 Safety, symbols, warnings

2.1	Warnings .....	5
2.2	Hazard symbols .....	5
2.3	User qualifications (target audiences) .....	7
2.4	Intended use .....	8
2.5	Foreseeable misuse .....	8
2.6	Structural changes to the control valve .....	9
2.7	Machine manufacturer/owner duties .....	9
2.8	Personal protective equipment .....	9
2.9	Residual risks .....	10
2.10	Environmental factors .....	12

# Contents

## 3 Technical data

<b>3.1</b>	<b>Design of LX-6 control valve and example circuit diagram.....</b>	<b>13</b>
3.1.1	Overview of LX-6 operation units .....	13
3.1.2	LX-6 example circuit diagram .....	13
<b>3.2</b>	<b>Design of LCX-6 control valve and example circuit diagram.....</b>	<b>14</b>
3.2.1	Overview of LCX-6 operation units .....	14
3.2.2	LCX-6 example circuit diagram .....	14
<b>3.3</b>	<b>Design of LX-3 control valve and example circuit diagram.....</b>	<b>15</b>
3.3.1	Overview of LX-3 operation units .....	15
3.3.2	LX-3 example circuit diagram .....	15

## 4 Packing, storage and transport

<b>4.1</b>	<b>Packing.....</b>	<b>16</b>
<b>4.2</b>	<b>Packing symbols .....</b>	<b>16</b>
<b>4.3</b>	<b>Storing the control valve .....</b>	<b>17</b>
<b>4.4</b>	<b>Transport.....</b>	<b>19</b>
<b>4.5</b>	<b>Returns .....</b>	<b>20</b>

## 5 Installation

<b>5.1</b>	<b>General information .....</b>	<b>24</b>
<b>5.2</b>	<b>Mechanical installation .....</b>	<b>24</b>
<b>5.3</b>	<b>Hydraulic installation .....</b>	<b>25</b>
<b>5.4</b>	<b>Connecting the control valve .....</b>	<b>23</b>

# Table of Contents

## 6 Commissioning

6.1	General information .....	26
6.2	Initial commissioning.....	26
6.3	Re-commissioning after an emergency stop.....	26
6.4	Re-commissioning after downtimes.....	26
6.5	Operation.....	26
6.6	Malfunction .....	26

## 7 Maintenance

7.1	General information .....	27
7.2	Maintenance work .....	27
7.3	Cleaning and maintenance .....	29
7.4	Repair work .....	29

## 8 Dismantling / disposal

8.1	Dismantling .....	30
8.2	Disposal .....	30

# 1 General information

## 1.1 Purpose

In particular, these installation and operating instructions provide information on the following aspects of the load-sensing sectional control valve in the X-Series:

- Storage and Transportation
- Assembly
- Commissioning
- Maintenance
- Dismantling/disposal

## 1.2 Scope of application for the installation and operating instructions

The control valve is made up of different sections. These installation and operating instructions take the different combinations which the parts can be supplied in into account.

The manufacturers of the control valve (HYDAC Mobilhydraulik GmbH and Nordhydraulic AB) will hereinafter be referred to as "HYDAC".

- These installation and operating instructions are part of the set of technical documentation which is aimed at various target audiences to ensure the safe and proper use of this product.
- As well as the right project planning, the correct implementation of procedures when performing all work on the hydraulic system has a direct impact on the products in the hydraulic system in terms of their operating characteristics, service life and operational safety.
- All work relating to transport and installation of the control valve, assembly of the hydraulic system and subsequent commissioning must be carried out by qualified personnel and inspected by the responsible specialists when necessary.
- All chapters of these installation and operating instructions must be read carefully and in full before the product is used. This document should be kept in an accessible location for future use.
- Further information on the products can be found at [www.hydac.com](http://www.hydac.com)

## 1.3 Integration of the control valve into the hydraulic system

When integrating the control valve into the hydraulic system, the machine manufacturer's instructions must be observed as well as any other relevant information:

- Technical data and information on the storage, installation, commissioning, maintenance and dismantling requirements which can be found in locations such as the corresponding data sheet, the installation drawing, the spare parts catalogue, order documents and the identification plate specifications.
- Legal regulations, installation regulations and safety regulations
- Local machine-specific regulations and requirements
- The proper use of tools, lifting equipment and transport equipment
- Care and cleanliness are imperative for the proper assembly of the control valve and the installation of spare parts
- The use of personal protective equipment

## 1.4 Manufacturers

The manufacturers are the HYDAC affiliate companies HYDAC Mobilhydraulik GmbH and Nordhydraulic AB. The country of origin can be found on the control valve's identification plate.

<b>HYDAC Mobilhydraulik GmbH</b> Industriestraße 66280 Sulzbach/ Saar Germany Phone: +49 6897 509-01 Fax: +49 6897 509-577
---

<b>Nordhydraulic AB</b> P.O. Box 189 SE-872 24 Kramfors Sweden Phone: +46 612 71 72 81 Fax: +46 706 75 65 85
---

## 1.5 Product description

The LX-series valves are pre compensated proportional directional control valves according to the load-sensing principle. The pressure compensator keeps the flow rate to the actuator constant, even if the system pressure varies.

The control can take place mechanically, hydraulically or electro-hydraulically (proportional, on/off). (with/without hand lever)

Detailed information on the technical characteristics, product features, design and function as well as application examples and instructions for optimal project planning can be found in the corresponding data sheet:

- Available at [www.hydac.com](http://www.hydac.com)

## 1.6 Identifying the control valve

The identification plate enables the load-sensing control valve to be clearly identified.

The information on the type label relates to the particular control valve as supplied. If the control valve has been modified compared to the delivery condition, it is possible that the type label specifications may no longer apply.

- Do not remove the type label.

If a consultation is required with HYDAC sales / service, the control valve must be identified. For this reason, the information on the identification plate should be noted down.

Below is an example of a standard HYDAC type label:

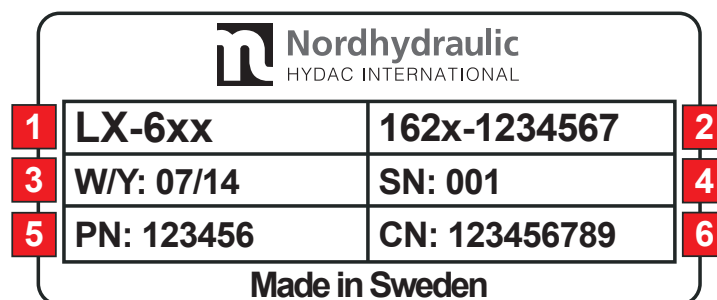

1	Designation	2	Material number
3	Week/year (manufacturing date)	4	Serial number
5	Production number	6	Customer number

## 1.7 Other identification plates on the control valve

Depending on the order, there can be some differences to the identification plate listed above. For example, the HYDAC logo can be replaced by the customer's logo on customer-specific type labels.

If there are any further labels or identification plates on the control valve, these are for customer identification purposes or internal HYDAC purposes.

## 1.8 Customer service

Customer service, testing and repairs can be carried out at the HYDAC head office or at all national and international HYDAC sales and service centres.

The following details are required when contacting us: designation, material number and serial number.

Contact at Headquarters:

### **HYDAC Systems & Services GmbH**

Plant 13

Friedrichsthalerstr. 15

66540 Neunkirchen/Heinitz

Germany

Phone: +49 6897 / 509-01

Fax: +49 6897 / 509-324

## 1.9 Information about these installation and operating instructions

These installation and operating instructions are aimed at qualified specialists as well as dealers. This document contains important information on how to transport the control valve safely and properly as well as how to install, dismantle, commission, operate and maintain it. This document also explains how simple malfunctions can be rectified.

Every person who works with the control valve must have read and understood these installation and operating instructions before starting any work. This also applies to specialists who have already worked with the same / a similar product or who have been trained by the manufacturer.

The illustrations in these installation and operating instructions are designed to support the reader's technical understanding and may vary from the actual version supplied due to its modular, sectional design.

## 1.10 Other relevant documents

The following documents must be observed in order to be able to use the control valve safely and correctly:

- The order documents and/or delivery documents for the control valve
- Installation drawing for the control valve
- Data sheet
- Local applicable standards and laws

## 1.11 Storage

These installation and operating instructions and any other relevant documents should be stored in close proximity to the product so that they can be easily accessed by specialist staff at any time.

The contents of these installation and operating instructions must be permanently and clearly preserved throughout the service life of the control valve.

## 1.12 Key

The following numbers/symbols are used in these installation and operating instructions:

Representation	Meaning	Description
▶	Instruction	Instructions not in a set order.
1. 2. .....	Instruction	Instructions with a set order
■	List	List not in a set order
xx	Item number	The item number is used to identify an object in a diagram and refer to it in the text

## 1.13 Abbreviations

The following abbreviations are used in these installation and operating instructions:

Representation	Description
mm	Length specification in millimetres
A	Electric current in amps
bar	Pressure in bar
mm <sup>2</sup> /s	Viscosity in square millimetres per second
l/min	Flow in litres per minute
V	Electrical voltage in volts
°C	Temperature in degrees Celsius

## 1.14 Exclusion of liability for these installation and operating instructions

These installation and operating instructions were made to the best of our knowledge. Nevertheless and despite the greatest care, it cannot be excluded that mistakes could have crept in. Therefore please understand that in the absence of any provisions to the contrary hereinafter our warranty and liability – irrespective of any legal reasons whatsoever – are to be excluded in respect of the information in these installation and operating instructions. In particular, we shall not be liable for lost profit or other financial loss.

This exclusion of liability does not apply in cases of intent or gross negligence. Moreover, it does not apply to defects which have been deceitfully concealed or whose absence has been guaranteed, nor in cases of culpable harm to life, physical injury and damage to health. If any material contractual obligation is negligently breached, liability shall be limited to foreseeable damage. Product liability claims remain unaffected.



## 2 Safety, symbols, warnings

### 2.1 Warnings

These installation and operating instructions describe the technical specifications and functions of the control valve. These installation and operating instructions contain warnings and are divided into action steps. Warnings are broken down according to the following template. Various pictograms are used which are tailored to the situation.









The word danger warns of a potentially dangerous situation that could result in death, severe injury and damage to property or the environment if not avoided.





The warnings are structured as follows:

Pictogram	<b>⚠ Warning</b>
	<b>Type and source of danger.</b>
	Consequences. » Safety measure

### 2.2 Hazard symbols

The following symbols are used in these installation and operating instructions:



Symbol	Meaning	Explanation
	General Danger	This warns of general hazardous situations which could result in death, severe injury and damage to property and/or the environment if safety precautions are not observed.
	Danger: Electrical voltage	This warns of electrically live components which can lead to death or severe bodily injuries if improperly handled.
	Hazard: Hot surfaces	Warns of dangerous situations such as burns.
	Risk: Hand injuries	Warns of dangerous situations such as hands being crushed or pulled in or other hand injuries.
	Slip hazard	Warns of hazardous situations such as slipping and falling.
	Hazard: Suspended load	Warns against standing under suspended loads.
	Health hazard	Warns of acutely toxic materials.
	Environmentally hazardous substances	Warns of acute or long-term environmental pollution.

Symbol	Meaning	Explanation
	Observe instructions for use	This is used to refer to a particular point in the installation and operating instructions.
	General mandatory action symbol	A mandatory action symbol requests a certain behaviour.
	Use a skin protection product	This mandatory action symbol requests that you use a suitable skin protection product before and/or after the activity.
	Use hearing protection	This mandatory action symbol requests that you use hearing protection to protect against noise.
	Wear protective goggles	This mandatory action symbol requests that you wear protective goggles to protect the eyes.

## 2.3 User qualifications (target audiences)

These installation and operating instructions are aimed at specialists with experience in dealing with mobile systems.

The relevant applicable country-specific regulations for health and safety at work must be observed.

 	 <b>WARNING</b>
	<b>Insufficient qualifications mean a risk of injuries!</b>
	<ul style="list-style-type: none"> <li>» All activities must only be carried out by qualified specialists</li> <li>» Unauthorised persons are not permitted to loiter in the hazard zone</li> </ul>

Qualification	Requirements for authorisation / task
Qualified specialist	<ul style="list-style-type: none"> <li>▶ Someone who, based on their training, knowledge and experience as well as their understanding of the applicable regulations, is able to assess the work assigned to them and identify any possible dangers Experience in dealing with hydraulic and electrohydraulic systems.</li> <li>▶ The absence of any personal restrictions which affect the person's ability to carry out the tasks</li> <li>▶ Product-specific training</li> </ul>
Specialist electrician	<p>Specialist training (electrical engineering), knowledge, experience and an understanding of the relevant standards and regulations enables qualified electricians to:</p> <ul style="list-style-type: none"> <li>▶ independently carry out work on electrical systems</li> <li>▶ independently assess the tasks assigned to them</li> <li>▶ independently recognise and avoid any potential hazards</li> <li>▶ The absence of any personal restrictions which affect the person's ability to carry out the tasks</li> <li>▶ Knowledge and experience in the relevant field of work</li> <li>▶ Knowledge of the relevant standards</li> </ul>
Customer service	<p>Customer service staff are service technicians who have been demonstrably trained and authorised by HYDAC to work with the product.</p> <ul style="list-style-type: none"> <li>▶ Ability to independently assess the tasks assigned to them</li> <li>▶ Ability to independently recognise and avoid any potential hazards</li> <li>▶ The absence of any personal restrictions which affect the person's ability to carry out the tasks</li> <li>▶ Knowledge and experience in the relevant field of work</li> <li>▶ Knowledge of the relevant standards</li> </ul>

## 2.4 Intended use

Claims for defects or liability – regardless of the legal foundation – do not apply in particular with incorrect or improper storage, assembly, commissioning, usage, maintenance, disassembly or other circumstances which the manufacturer is not responsible for.

The manufacturer assumes no responsibility for determining the interfaces for installation in a machine or for the usage and functionality of the control valve in the machine.

Control valves do not fall within the scope of the EU Machinery Directive 2006/42/EG. The control valve is exclusively intended to be used with other components to form an incomplete or complete machine. The control valve may only be put into operation once it has been installed in the machine which is it intended for and once the required safety level for the machine according the Machinery Directive has been achieved.

Intended use also extends to the following:

- That the control valve was exclusively developed, designed and built for industrial and commercial use
- Observing the available documentation and adhering to inspection and maintenance requirements
- That its use is confined to the stationary and/or mobile hydraulics industry
- That any other use or improper use is prohibited

## 2.5 Foreseeable misuse

The risks of improper use or use deviating from intended use lie with the machine manufacturer/owner. This machine can pose a particular danger to people, objects and the environment if:

- unauthorised spare parts are used
- these installation and operating instructions and documents accompanying the product are ignored
- changes or alterations are made to the control valve
- operating materials are used which are not approved of by the manufacturer
- unauthorised changes are made to the control valve
- the control valve is used in an explosive atmosphere
- the control valve is used in aviation or aerospace
- the control valve is used as a safety component
- the control valve is not used in line with the operating data in the data sheet

## 2.6 Structural changes to the control valve

We would like to point out that changes to the control valve (e.g. purchasing additional options) may result in the information in these installation and operating instructions no longer being completely valid or sufficient. All of the control valve components may only be replaced with original parts.

The delivered system has only been tried and tested by HYDAC for the application purposes that HYDAC is aware of. The delivered control valve has been tested by HYDAC in accordance with the technical data specified in the data sheet. If a control valve is changed, for example if physical alterations are made or if additional parts are added to it, for liability and insurance reasons it is vital for sufficient testing and documentation to be performed with subsequent approval. This must be performed by the party that made the changes.

## 2.7 Machine manufacturer/owner duties

The machine manufacturer/owner must regularly train their specialist staff on the following topics:



- Observing and applying the installation and operating instructions as well as any legal regulations
- Maintaining proper operation
- Providing personal protective equipment (PPE)

## 2.8 Personal protective equipment

When working on the control valve, the specialist staff must be protected from hazards.

Personal protective equipment must be worn when there is direct access to hydraulics products. It must be ensured that the protective equipment is in perfect condition.





The local regulations and machine manufacturer's/owner's instructions must be observed. The following protective equipment is recommended in particular:





Symbol	Meaning	Description
	Work clothing	Wear close-fitting work clothes with a high tensile strength. Avoid loose or protruding parts. These could become caught in moving machine parts.
	Safety shoes	Safety shoes have good anti-slip properties, especially in wet conditions, and a high puncture resistance, e.g. against nails. They protect the feet from falling objects e.g. during transport.
	Protective goggles	Protective goggles protect the eyes against flying parts and fluid splashes, among other things.

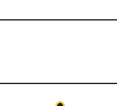

## 2.9 Residual risks





The use of technical products comes with risks. Risks which cannot be ruled out by either constructive measures or safety devices are known as residual risks.



The safety information in these installation and operating instructions points out the known residual risks. If additional risks arise during operation, the machine manufacturer/owner is obligated to inform HYDAC immediately.





 <b>WARNING</b>	
   	<b>Uncontrolled leakage of hydraulic fluids.</b>
	Tubing and piping can be subject to pressure during operation.
	» These must be depressurised before loosening/removing fittings or tube and pipe connections
	» Drain tube and pipe connections carefully
» Wear personal protective equipment	
» Collect any potential escaping fluids and properly dispose of them	



 <b>WARNING</b>	
  	<b>Risk of burns on hot surfaces.</b>
	There is a risk of injury on hot surfaces such as the control valve housing, piping and escaping hydraulic oil.
	» Let surfaces cool down before starting any work
	» Wear appropriate protective clothing
» Avoid fire hazards and sources of ignition	

 <b>WARNING</b>	
	<b>Flying or bursting parts.</b>
	Tubing and piping can burst during machine operation.
	» Max. pressurisation according to manufacturer specifications
» Check piping according to manufacturer specifications	

  	 <b>WARNING</b>
	<p><b>Skin lesions.</b></p> <p>Contact with operating fluids can lead to skin damage. Vapours from operating fluids can lead to respiratory tract irritation.</p> <ul style="list-style-type: none"> <li>» Wear personal protective equipment</li> <li>» Use suitable skin protection products, skin cleaning products and skin care products</li> <li>» Observe skin protection plans</li> </ul>

 	 <b>WARNING</b>
	<p><b>Risks due to an increased level of noise when machines are running.</b></p> <p>There is a risk of hearing loss.</p> <ul style="list-style-type: none"> <li>» Take noise protection measures</li> <li>» Wear personal protective equipment above 80dB(A)</li> </ul>

   	 <b>WARNING</b>
	<p><b>Leaking hydraulic fluids.</b></p> <p>The leakage of operating fluids must be prevented as oily work surfaces and treads on machine platforms and oily hall floors pose a slip hazard. Tools on flats or components slip more easily and fire hazards can occur.</p> <ul style="list-style-type: none"> <li>» Use collection trays</li> <li>» Slip hazard on work stations and travel paths</li> <li>» Personal protective equipment</li> <li>» Wipe up leaking hydraulic fluids with an oil binding agent/oil-absorbent cloth</li> </ul>

 	<b>⚠ WARNING</b>
	<p><b>Risk of short circuiting during maintenance.</b></p> <p>Maintenance work on mobile vehicles poses the risk of a short circuit.</p> <ul style="list-style-type: none"> <li>» Disconnect the vehicle's battery from the on-board power supply</li> <li>» Disconnect the battery when carrying out welding work on the vehicle</li> </ul>

## 2.10 Environmental factors

	<b>⚠ WARNING</b>
	<p><b>Corrosion or functional failure caused by chemical or aggressive environmental factors.</b></p> <p>Contact with chemical or aggressive environmental factors (e.g. sea water, fertiliser or de-icing salt) may lead to corrosion and/or functional failure.</p> <ul style="list-style-type: none"> <li>» Check for leaks</li> <li>» Take measure to protect against environmental factors</li> </ul>



# 3 Technical data

## 3.1 Design of LX-6 control valve and example circuit diagram

### 3.1.1 Overview of LX-6 operation units

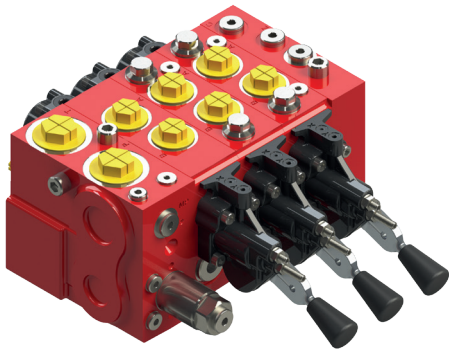

LX-6 control valve with manual operation

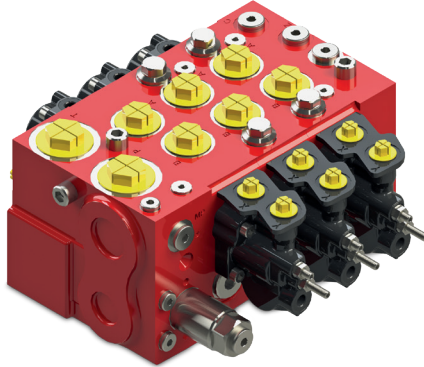

LX-6 control valve with hydraulic operation

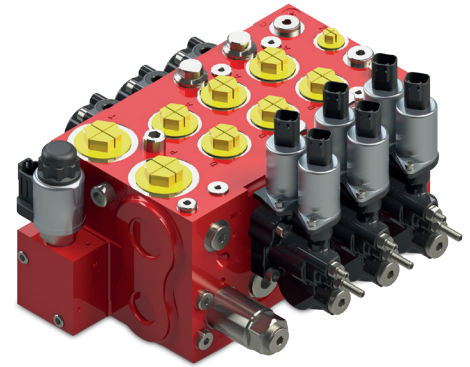

LX-6 control valve with electro-hydraulic operation

### 3.1.2 LX-6 example circuit diagram

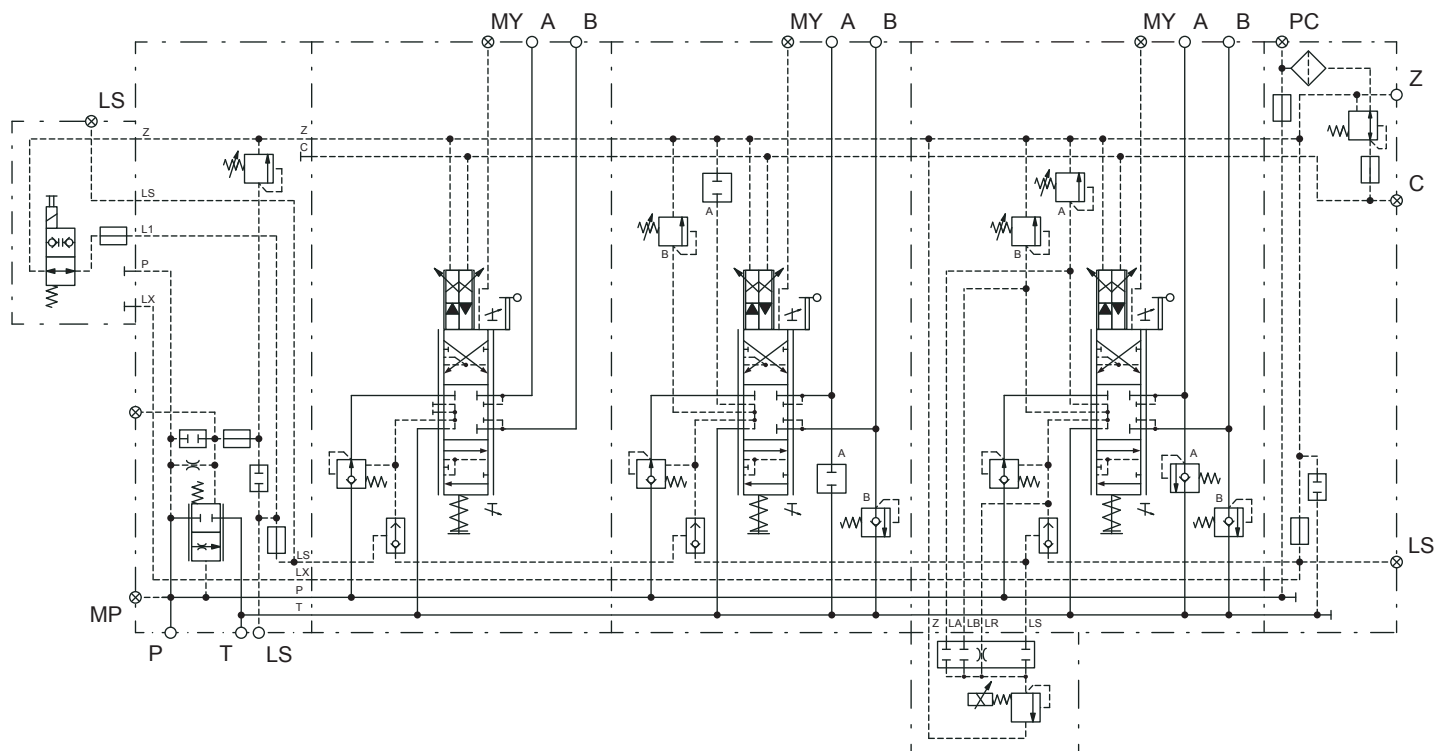

## 3.2 Design of LCX-6 control valve and example circuit diagram

### 3.2.1 Overview of LCX-6 operation units



LCX-6 control valve with manual operation



LCX-6 control valve with hydraulic operation



LCX-6 control valve with electro-hydraulic operation

### 3.2.2 LCX-6 example circuit diagram

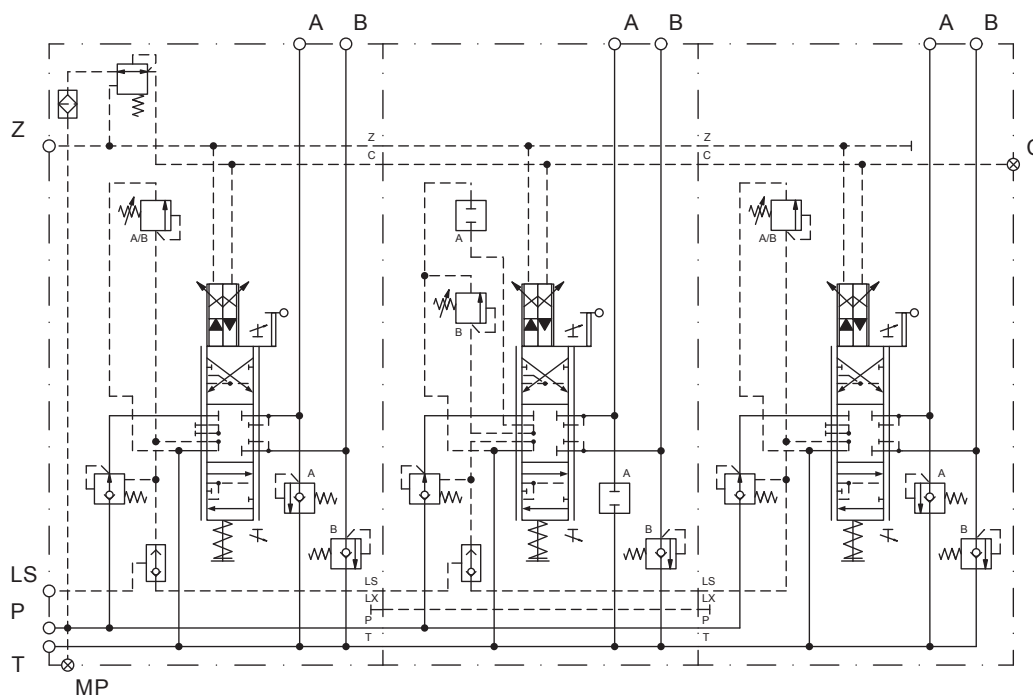

### 3.3 Design of LX-3 control valve and example circuit diagram

#### 3.3.1 Overview of LX-3 operation units



LX-3 control valve with manual operation

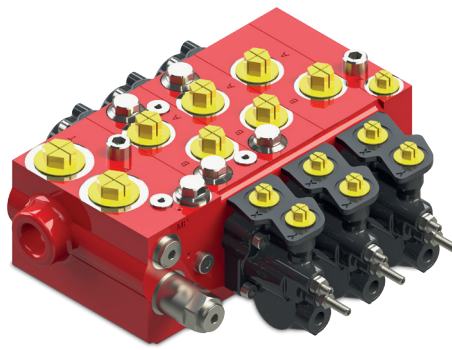

LX-3 control valve with hydraulic operation

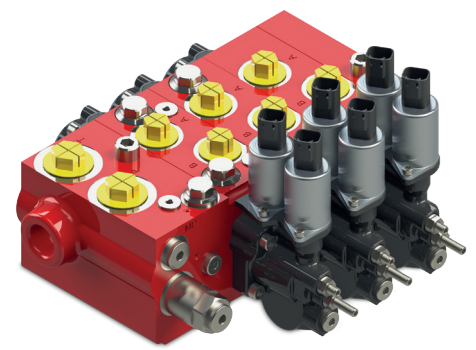

LX-3 control valve with electro-hydraulic operation

#### 3.3.2 LX-3 example circuit diagram

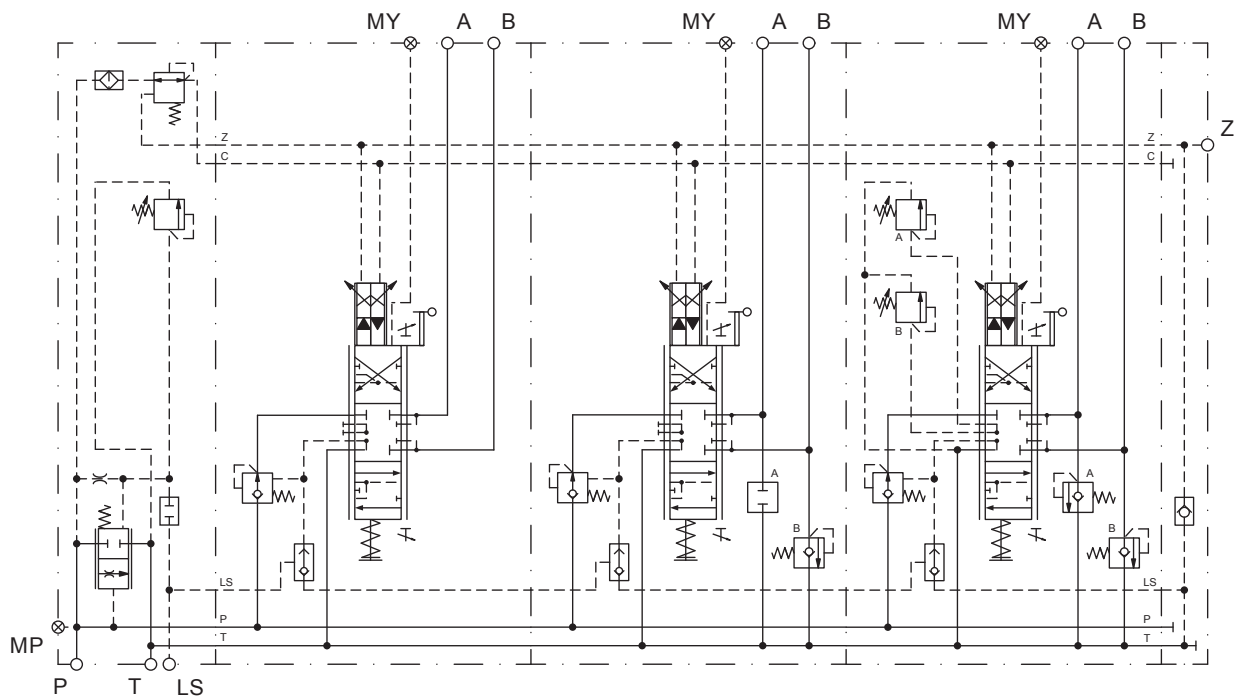

# 4 Packing, storage and transport

## 4.1 Packing

The control valve and spare parts are packed in a product-specific way to protect them against transport damage and corrosion. When receiving and unpacking the control valve, check for transport damage.

Always place the packaging on a flat, stable surface.



Store the packaging in a weather-protected area for later transport.

Any packing no longer required should be recycled or disposed of in accordance with the relevant national regulations.

	<b>NOTICE</b>	
	<b>Damage of the control valve.</b>	
	<ul style="list-style-type: none"><li>» Handle the control valve with care</li><li>» Observe the packing symbols</li><li>» Only remove the packing when the control valve is at its site of operation</li><li>» Transport the control valve to its site of operation using a forklift truck or a hand pallet truck</li><li>» In the event of damages, HYDAC must be informed immediately</li></ul>	

## 4.2 Packing symbols

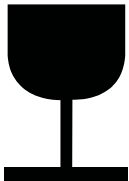
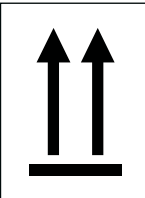
The following symbols can be attached to the packaging:

Symbol	Meaning	Description
	Fragile	Handle the control valve with care. Avoid pressure and strong jolting movements.
	This way up	The arrows point to the top of the control valve. Store and transport the control valve upright. Do not tilt!
	Sensitive to moisture	Protect the control valve from wet conditions when storing and transporting.

### 4.3 Storage of the control valve

Particular attention must be paid to the following points when storing the control valve:

- Storage areas must be free from corrosive substances, vapours and gases
- The control valve should be stored in such a way that it is protected from contamination, weather conditions, dust, moisture and mechanical damage
- The control valve must be stored in a shock-proof way and must not be stacked
- Do not remove any protective covers or protective plugs
- Unpacked control valve must be protected with a dust-proof cover. No condensation water may occur under the cover.
- The control valve must not be stored on sensitive add-on components such as operation units, sensors, solenoids or valves
- Direct sunlight or UV light is not permitted (e.g. well-lit windows or direct neon lighting)
- Relative humidity (no condensation): max. 65%
- Recommended storage temperature: +5 °C to +25 °C
- Minimum storage temperature: -20 °C
- Maximum storage temperature: +40 °C

	<b>NOTICE</b>	
	<b>Max. storage time</b>	
	<ul style="list-style-type: none"><li>» The max. permitted storage time is two years</li><li>» Check correct storage of the control valve once a month</li><li>» Warranty claims are rendered void if the requirements and storage conditions are not observed and after the maximum storage time has expired</li></ul>	

	<b>NOTICE</b>	
	<b>Damage of the control valve.</b>	
	<ul style="list-style-type: none"><li>» Storage out in the open leads to corrosion can render the control valve unusable</li><li>» When storing in a maritime or tropical climate or in humidity in facilities without an air-conditioning system, the climatic conditions lead to corrosion and can negatively affect the control valve's function or render it unusable</li></ul>	

## After delivery

As standard, control valves are delivered with an external coating as corrosion protection ex works.

The mineral oil used for testing in closed control valves provides internal corrosion protection.

Control valves or surfaces with no coating are not protected from corrosion.

Long freight, storage, decommissioning times or delayed installation leads to rust formation.

To prevent this, additional corrosion protection measures must be taken.

Recommended procedure after longer storage time:

1. Check the complete control valve for damage and corrosion before installation.
2. Check the control valve for correct function and leaktightness during initial start-up (see 6. Commissioning).

After maximum storage time it is recommended to have the control valve checked by the responsible HYDAC Service.

## After removal/dismantling

If a removed control valve has to be stored, it must be protected from corrosion for the duration of storage.

Following instructions are recommended for control valves which are operated with hydraulic fluid on mineral oil basis:

1. Clean and drain the control valve
2. Plug/seal all ports airtight
3. Protect all non-painted or coated surfaces of the control valve with mineral oil
4. Store the control valve according to the points listed at the beginning of this section
5. If necessary, send the control valve to HYDAC Systems & Services GmbH for repair (see 1.8 Customer service)

## 4.4 Transport

Lifting accessories connect the load hooks to the load.

Depending on the transport task or the type of goods to be transported, there are different types of lifting accessories available. These can be used in combination. Round slings and lifting straps are particularly suited to gentle transportation.

	<b>NOTICE</b>	
	<b>Improper transport.</b>	<ul style="list-style-type: none"><li>» Handle the control valve with care</li><li>» Observe the packing symbols</li><li>» If possible, only remove the packing when the control valve is at its site of operation</li><li>» Transport the control valve to its site of operation using a forklift truck or a hand pallet truck</li><li>» Only use suitable lifting accessories</li></ul>

	<b>WARNING</b>	
	<b>Suspended and falling loads.</b>	<p>Loads can fall down during a lifting procedure and lead to death or serious injuries.</p> <ul style="list-style-type: none"><li>» It must be ensured that the lifting equipment and lifting accessories have a sufficient load-bearing capacity</li><li>» Suitable personal protective equipment must be worn</li><li>» Check lifting equipment and load lifting accessories for damages</li><li>» Only use load lifting accessories in accordance with the Machinery Directive 2006/42/EG</li><li>» Never place yourself under or in the pivoting range of suspended loads</li><li>» Always transport the control valve as close as possible to the floor</li><li>» Attach the lifting equipment to the approved transport screws on the control valve housing (see following illustration)</li><li>» When leaving the work station, the load must be set down</li></ul>



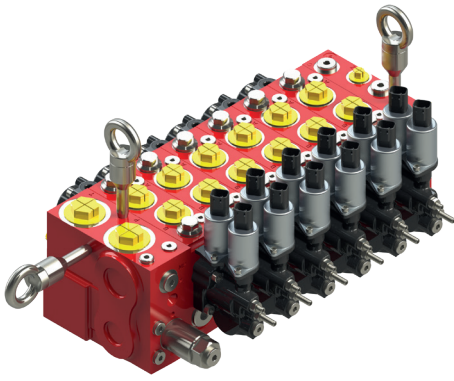

Transport screws LX-6, control valve



Transport screws LCX-6, control valve

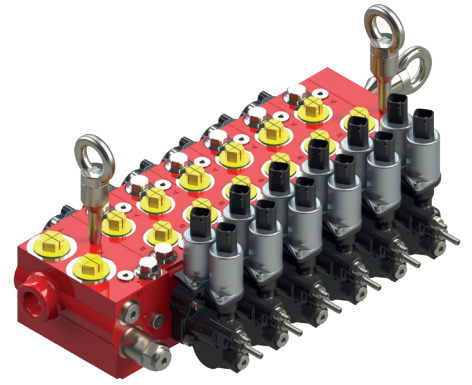

Transport screws LX-3, control valve

#### 4.5 Returns

Before transport, used control valves must be completely emptied and the inlet and outlet openings must be closed. Suitable packing must be used when sending the control valve or components of the control valve to HYDAC Systems & Services GmbH, e.g. for repair work (see 1.8 Customer service). Particular care should be taken to ensure that the components are protected against impacts, wet conditions and contamination.





# 5 Installation

## 5.1 General information

Particular attention must be paid to the following points during installation:

- The work area must be clean, dry and free of foreign objects
- The system that the control valve is going to be installed into must be electrically and hydraulically de-energised and secured against being switched on accidentally
- There must be sufficient lighting available
- It must be ensured that only specialist staff are allowed in the work area
- That all necessary on-site connections are available for use

	<b>NOTICE</b>
	<b>Pressure fluid escaping or being spilled.</b>
	Environmental pollution and contamination of the groundwater. <ul style="list-style-type: none"><li>» Use a drain tray underneath the control valve when filling or draining</li><li>» Use suitable binding medium if pressure fluid is spilled</li><li>» Observe the specifications in the safety data sheet of the pressure fluid and the machine/system manufacturer</li></ul>

	<b>NOTICE</b>
	<b>Heat generation in components.</b>
	If heat is generated in components (e.g. solenoids), nearby products may be damaged if sufficient safety distances are not observed. <ul style="list-style-type: none"><li>» Observe sufficient safety distances from nearby products to eliminate the risk of damage</li></ul>

	<b>NOTICE</b>
	<b>Improper transport of the control valve can lead to material damage.</b>
	<ul style="list-style-type: none"><li>» Handle the control valve with care</li><li>» Observe the packing symbols</li><li>» Only remove the packing when the control valve is at its site of operation</li><li>» Transport the control valve to its site of operation using a forklift truck or a hand pallet truck</li></ul>

## 5.2 Mechanical installation

The control valve should be mounted at the three mounting points free from distortion (according to the installation drawing).

Unless otherwise specified in the technical documentation, the control valve can be installed in any mounting position.

<b>NOTICE</b>	
	<b>Contact surface and tightening torque.</b>
	Damaged/unsuitable surfaces/flatness of the contact surface or excess tightening torque may lead to leakage or blockage of the spool. <ul style="list-style-type: none"><li>» Check the flatness of the contact surface in the machine (tolerance: 0.5 mm)</li><li>» Use standard values of the relevant borehole sizes and screw strength classes</li></ul>

Install the control valve as follows:

1. Check the contact face for damage
2. Fix the control valve to the installation site
3. Attach the fastening screws to the control valve in accordance with the installation drawing and tighten in accordance with conventional standard values.  
Excess tightening torque may lead to blockage of the spool. In this case, the tightening torque must be reduced accordingly, and it must be ensured that the screws have sufficient residual gripping force.

### 5.3 Hydraulic installation

The machine manufacturer is responsible for laying the hydraulic lines. The X-series control valve must be connected to the hydraulic system according to the machine manufacturer's hydraulic circuit diagram.

	<b>NOTICE</b>
	<b>Operating with plastic protective plugs</b> Operating the control valve with protective plugs may result in injury or in damage to the control valve. <ul style="list-style-type: none"><li>» Remove all protective plugs before commissioning and use line connections or suitable pressure-resistance metallic screw plugs.</li></ul>

If there is no pressure relief valve in the control valve, a pressure relief valve must be fitted into the hydraulic system for maximum pressure protection.

### 5.4 Connecting the control valve

Connect the control valve as follows:

1. Mount the control valve according to 5.2
2. Read and understand the hydraulic circuit diagram
3. Remove any protective plugs or plug screws that are not required from the control valve
4. The sealing surfaces, hydraulic connections and functional surfaces must be checked to ensure that they are not damaged

	<b>NOTICE</b>
	<b>Damaged seals.</b> Improperly mounted seals can lead to leaks on the control valve. <ul style="list-style-type: none"><li>» Only use seals that are free of defects</li><li>» Do not use damaged seals</li><li>» Only use seals that are approved by the manufacturer</li></ul>

5. Only rinsed and clean hydraulic lines may be used
6. Connect the hydraulic lines
7. All screws must be tightened correctly (observe the tightening torques specified by the manufacturer)
8. All tightened screws must be marked

# 6 Commissioning

## 6.1 General information

Particular attention must be paid to the following points during commissioning:

- Let the control valve acclimatise for a few hours before commissioning so that no condensation can take place in the housing
- It must be ensured that all electric and hydraulic connection points are occupied and connected, or that hydraulic connections that are not in use are closed with correct screw plugs.
- Temperature shocks must be avoided

	<b>NOTICE</b>	
	<b>Temperature shocks.</b>	
	Risk of blocked main spool. <ul style="list-style-type: none"><li>» Max. 20 °C temperature difference between control valve and pressure fluid.</li><li>» The control valve must warm up consistently at temperatures below 0 °C with low load</li></ul>	

- Operate exclusively with sufficient pressure fluid
- It must be ensured that the entire control valve including pilot oil circuits as well as the connected working lines are filled with pressure fluid and that they remain filled during operation.
- Use pressure fluids as specified in the data sheet with appropriate viscosity and cleanliness classification

	<b>NOTICE</b>	
	<b>Mixing pressure fluids.</b>	
	Product may be damaged. <ul style="list-style-type: none"><li>» Ensure that different pressure fluids are compatible according to manufacturer's specifications</li></ul>	

	<b>NOTICE</b>	
	<b>Contamination of the pressure fluid.</b>	
	Contamination of the pressure fluid may lead to premature blockage and malfunction of the control valve. <ul style="list-style-type: none"><li>» Work environment free from dust and foreign material</li><li>» Use clean connections, hydraulic lines and attachment parts (e.g. measuring instruments)</li><li>» When filling with pressure fluids, use a suitable filtration system to filter them to minimise the ingress of solid particle contamination and water into the hydraulic system</li></ul>	

	<b>NOTICE</b>	
	<b>Ingress of fluids and foreign particles.</b>	
	Loss of protection class and risk of short circuit. <ul style="list-style-type: none"><li>» Ensure all seals and closures of the connectors are leak-tight.</li></ul>	

## 6.2 Initial commissioning

Put the control valve into operation for the first time as follows:

1. The electrical and hydraulic supply must be secured
2. The operating instructions for the machine that the control valve is being installed into must be observed
3. Vent the control valve / hydraulic system
4. Check the control valve / hydraulic system for leakage, operating temperature and unusual noises
5. Perform a function test – slowly increase the pressure in the system to the operating pressure

## 6.3 Re-commissioning after an emergency stop

For correct re-commissioning after an emergency stop, the machine's operating instructions must be observed.

## 6.4 Re-commissioning after downtimes

If the control valve has been out of operation for longer than six months, the step described in chapter 6.2 "Initial commissioning" must be followed.

	<b>NOTICE</b>	
	<b>Re-commissioning after downtimes</b>	
	Re-commissioning can, for example, lead to leaks on the control valve.  » The information regarding (re-)commissioning after downtimes, as specified in the machine's operating instructions, must also be observed	

## 6.5 Operation

No adjustments or alterations are necessary on the control valve during operation.

The control valve is only approved for use in the permitted operating ranges (e.g. pressure, nominal flow, temperature, environmental conditions) which are specified in the values listed in the technical data.

The machine manufacturer / owner is responsible for the correct project planning and implementation.

	<b>NOTICE</b>	
	<b>Chemical or aggressive environmental conditions.</b>	
	If the control valve is exposed to chemical or aggressive environmental conditions, such as sea water, fertiliser or de-icing salt, this may lead to corrosion, ingress of dirt and in extreme cases to functional failure of the unit. If leakage occurs, pressure fluid may escape.  » Take appropriate measures to protect the control valve and its actuating elements from chemical and aggressive environmental conditions	

Hysteresis and reaction times of proportional and on-off solenoids may increase as the result of increasing pressure fluid viscosity when the temperature decreases.

	<b>NOTICE</b>	
	<b>Temperature shocks</b>	
	Risk of blocked main spool.  » Max. 20 °C temperature difference between control valve and pressure fluid.  » The control valve must warm up consistently at temperatures below 0 °C with low load	

## 6.6 Malfunction

Particular attention must be paid to the following points in the event of emergency maintenance:

- Define and close off the safety zone
- Operate the machine at a considerably reduced speed / pressure
- The troubleshooting should only take place when safety protection devices are active
- A qualified electrician should be consulted in the case of electrohydraulic machines
- Risks posed by neighbouring machines or for people on neighbouring machines must be ruled out
- Any steps taken, settings and their adjustments must be documented  
All modifications to the machine must be clearly recorded in the machine documentation and, if necessary, in the maintenance log book
- All installed parts must be chosen to suit the operating pressures and operating fluids
- Suitable lifting equipment and lifting accessories must be used for the dismantling and installation as well as for any transport

Particular attention must be paid to the following points after the emergency maintenance:

- Check connections
- Check loosened screws, line connections and electrical plug connections for a secure and tight fit
- Once the maintenance work has been finished, it must be ensured that any closed tank lines are reopened
- Deactivate any activated safety protection devices
- Fill and vent hydraulic components
- Perform a function test. Start with a low pressure and slowly increase the pressure.

# 7 Maintenance

## 7.1 General information

Maintenance preserves the operational readiness and prevents early wear. Maintenance can be divided into:

- Inspection
- Maintenance
- Repair

The machine manufacturer is responsible for ensuring that the following maintenance intervals and the relevant country-specific inspection requirements are observed.

The machine manufacturer's maintenance intervals in terms of inspection, servicing and repair work must be observed.

Safety protection devices must not be intentionally deactivated or removed.

If there is a malfunction, always check whether the on-board power supply/supply voltage is available and carry out a diagnosis. The safety information in chapter 2 "Safety, symbols, warnings" must be observed.

Particular attention must be paid to the following points during maintenance:

- Wait for the machine to come to a standstill
- Only carry out maintenance work on the machine when the energy supply is switched off and protected against turning on again
- It must be ensured that only specialist staff are allowed in the work area
- An inspection round must be carried out for the entire machine
- Attention must be paid to the safe reduction of the machine's residual energy (e.g. pressure reduction, electrics, pneumatics)
- The machine manufacturer's documentation must be observed
- Order and cleanliness should be ensured during all maintenance work
- Keep travel paths free

## 7.2 Maintenance work

Particular attention must be paid to the following points when working on the control valve:

- Check connections
- Check loosened screws, line connections and electrical plug connections for a secure and tight fit
- Once the maintenance work has been finished, it must be ensured that any closed tank lines are reopened
- Reactivate any deactivated safety protection devices
- Fill and vent the hydraulic system
- All maintenance work carried out on the control valve must be documented

## 7.3 Cleaning and maintenance

	NOTICE
	<p><b>Damaging to the hydraulic system and seals.</b></p> <p>The jet of a high-pressure cleaner can damage the seals and electrical system of the control valve!</p> <p>It can result in corrosion, ingress of dirt and in extreme cases loss of function.</p> <p>» Do not point high-pressure cleaners at sensitive components like operation units, electrical connections and components.</p>

The control valve requires low maintenance if it is used as intended.

The service life of the control valve is significantly affected by the quality of the operating fluid.

For cleaning and care of the control valve:

- Check that all seals and connectors are positioned securely to ensure that no moisture can get into the control valve during cleaning
- Use only water to clean the control valve and, where necessary, a mild cleaning detergent. Do not use solvents or aggressive cleaning products
- to remove significant external contamination and to keep important components clean, such as actuating elements, sensors, solenoids or valves
- Use non-fibrous cleaning cloths for cleaning.

Task	Interval
Cleaning	Regularly, depending on application
Checking the control valve for external leakage and abnormal noises	Daily
Checking the operating temperature	Weekly
Testing mounting elements for a tight and secure fit when the machine has cooled down and is in a depressurised, de-energised state	Monthly
Operating fluid	According the machine manufacturer's specifications

## 7.4 Repair work

Repair work can also be carried out by:



- Distributors
- HYDAC customer service
- Specialists

	NOTICE
	<p><b>Only use original HYDAC spare parts.</b></p> <p>Failing to use original HYDAC spare parts can lead to damages, functional impairments and safety risks.</p> <p>» Only original HYDAC spare parts are to be used</p>



# 8 Dismantling / disposal

## 8.1 Dismantling

  	<b>⚠ WARNING</b>
	<b>Danger due to high pressure in the hydraulic system.</b>
	<ul style="list-style-type: none"><li>» The machine must be secured according to the machine manufacturer's specifications</li><li>» It is essential to depressurise the entire hydraulic system according to the machine manufacturer's specifications</li><li>» The successful reduction of the system pressure must be checked again before opening the hydraulic system</li></ul>

Particular attention must be paid to the following points before dismantling the control valve:





- Physically disconnect the power supply – discharge any residual energy (see 7.1).
- Protect against switching on again (see 6.6, Activating safety protection devices)
- Work on electrical mechanisms may only be performed by qualified electricians or specialists trained in electrical engineering.
- Remove raw materials and supplies and dispose of these according to the applicable national regulations.

Properly clean dismantled components / systems and break them down according to the occupational safety and environmental protection regulations valid in the country of installation.

## 8.2 Disposal

The control valve consists of different materials. Each of these materials must be disposed of according to the country-specific regulations. Particular attention must be paid to the following points:

- It must be ensured that the dismantled components / systems are disposed of properly
- Recycle any metals
- Recycle any electrical / plastic parts
- Recycle any operating fluids
- Dispose of any remaining materials according to their material type
- The regulations valid in the specific country must be observed
- The control valve does not contain any batteries

 <b>WARNING</b>	
  	<b>Incorrect disposal poses a risk to people, objects and the environment.</b>
	» The manufacturer's safety data sheets must be observed during disposal
	» Use specialist companies to dispose of lubricants, auxiliary materials and electrical waste
	» If there is any uncertainty, further information can be found by contacting your local authorities or a waste disposal company

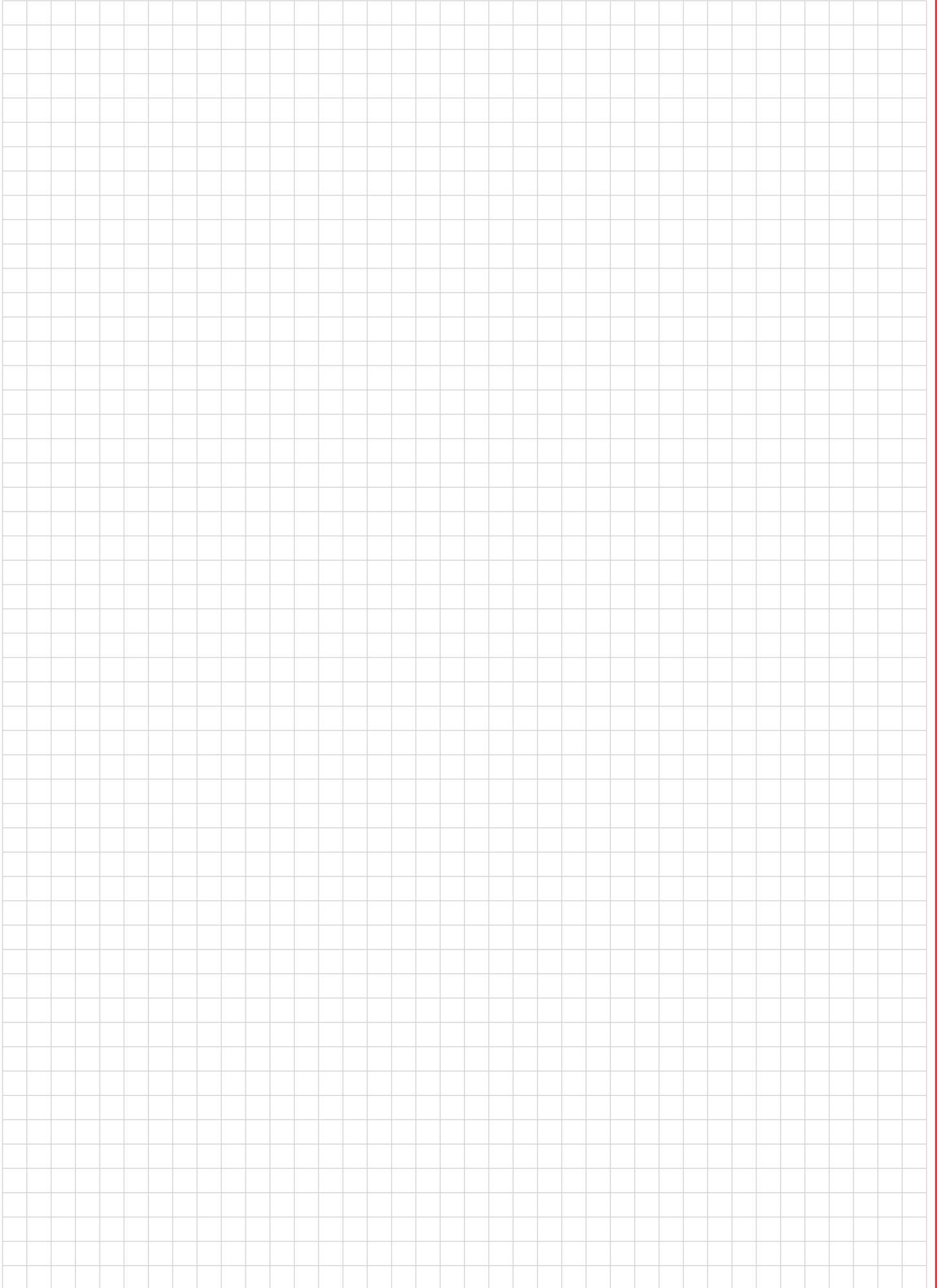



Accumulator Technology 30,000

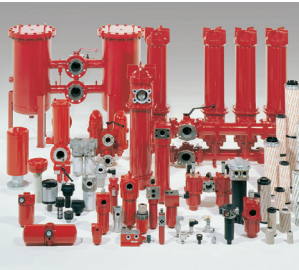

Filter Technology 70,000



Control Technology 18,500



Filter Systems 79,000

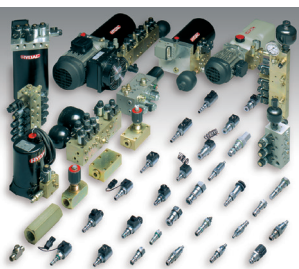

Compact Hydraulics 53,000



Accessories 61,000



Electronics 180,000



Cooling Systems 57,000

**Global presence.  
Local Expertise.  
www.hydac.com**

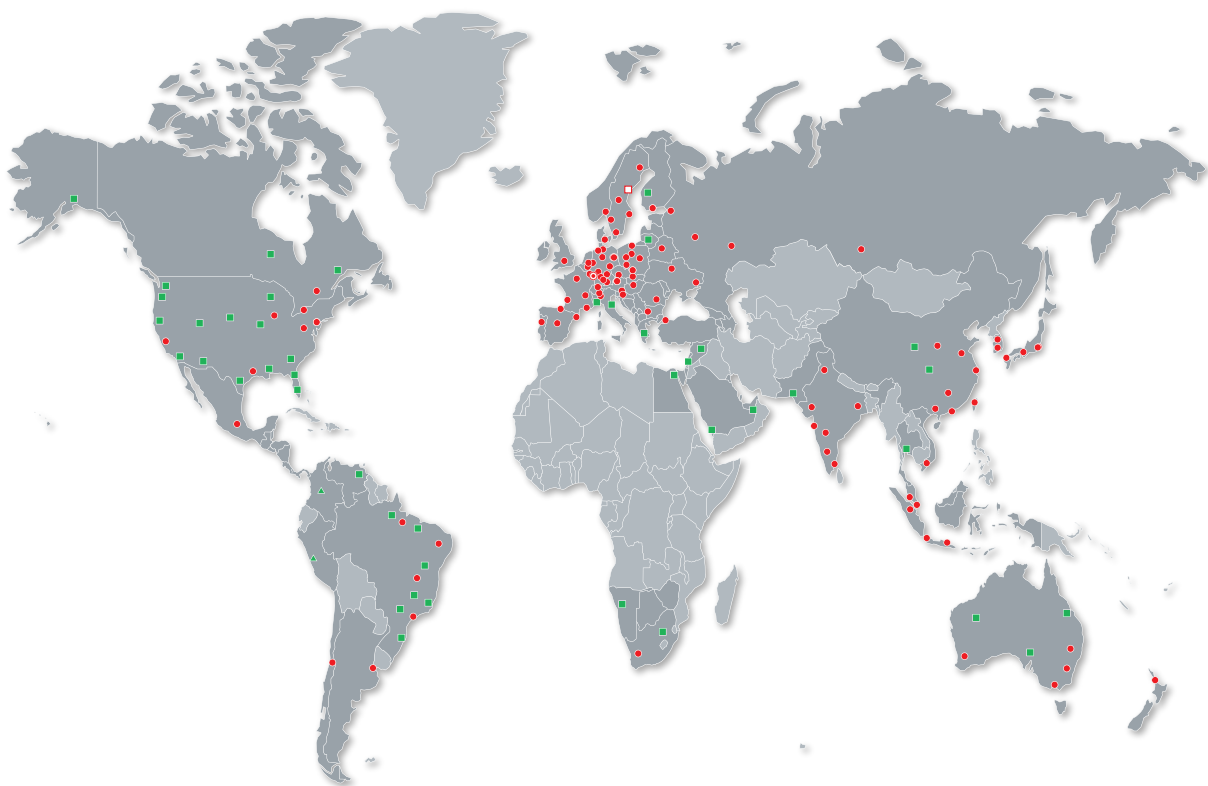

- ⊙ HYDAC Head Office
- HYDAC Companies
- HYDAC Sales and Service Partners
- ▲ Free Sales Partners
- Nordhydraulic Headquarters

**HYDAC INTERNATIONAL**

**HYDAC MOBILHYDRAULIK  
GMBH**

Industriestraße  
66280 Sulzbach/Saar  
Germany

Phone: +49 6897 509-01  
Fax: +49 6897 509-577



**Nordhydraulic**  
HYDAC INTERNATIONAL

**NORDHYDRAULIC AB**

P.O. Box 189  
872 24 Kramfors  
Sweden

Phone: +46 612 71 72 81  
Fax: +46 706 75 65 85

Internet: www.hydac.com