

4/2- and 4/3-directional spool valve solenoid-operated, direct-acting 4WE 10

DESCRIPTION

HYDAC 4/2- and 4/3-directional spool valves of the 4WE 10 series are directional valves for oil hydraulic systems which are used to open and close flow paths. The valve operates by oil-immersed solenoid. During this process, the solenoid pushes the valve's control spool into the respective position to obtain the desired flow path.

FEATURES

- Direct-acting, solenoid-operated directional valve
- Interface according to DIN 24340 Form A10, ISO 4401-05
- Removable high-performance solenoid coil, no need to open the hydraulic system during replacement
- Coil rotatable by 360°, allows flexible installation
- Electrical connection in several versions available
- With concealed manual override, additional versions available



Nominal size 10
up to 160 l/min
up to 350 bar

CONTENTS

Description	1
Features	1
Model code	2
Spool types / symbols	3
Function	4
Section view	4
Technical data	4
Performance	5
Dimensions	6
Electrical connections	7
Manual overrides	7
Accessories	8

MODEL CODE

4WE 10 D - OF A01-24 D G /V

Type

Solenoid-operated directional valve with 4 main ports, direct-acting

Nominal size

10

Piston symbol

See page 3

Version

Not specified = with return spring

-OF = without return spring, with detent (with D symbol only)

Series

A01 = specified by the manufacturer

Rated voltage of the solenoid coil¹⁾

12 = 12 VDC

24 = 24 VDC

96 = 96 VDC*

205 = 205 VDC*

* only in combination with the electrical connection G

Type of voltage

D = DC voltage

Electrical connection (for details see page 2)¹⁾

G = device plug, DIN EN 175301-803 A

N = device plug, Deutsch

N01 = device plug, Deutsch with suppressor diode

T = device plug, Junior Timer

Material of seal

/N = NBR

/V = FKM

Manual override (for details, see page 2)

Not specified = with concealed manual override (standard)

/M1 = with manual override

/M4 = with knurled nut

Orifice insert¹⁾

Not specified = no orifice insert

/YXX : Y = Port P, A, B or T

XX = diameter (e.g. 12 = 1.2 mm)

¹⁾ Other models on request

SPOOL TYPES / SYMBOLS

4/2-DIRECTIONAL SPOOL VALVES

Type	Basic symbol	With intermediate position
AE		
BE		
BJ		
C		
D		
EA		
EB		
GA		
GB		
HA		
HB		
JA		
JB		
QA		
UA		
Y		

With return spring

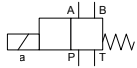

With detent (...-OF)

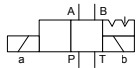

4/3-DIRECTIONAL SPOOL VALVES

Type	Basic symbol	With intermediate position
E		
F		
G		
H		
J		
L		
M		
P		
Q		
R		
U		

FUNCTION

The solenoid-operated directional spool valves of the 4WE 10 type are used to direct nominal flow and consist of one valve housing (1) with an associated valve spool (2). Depending on the type, the valve is equipped with at least two return springs (3) and with one or two pole tubes (4) and solenoid coils (5) each.

The hydraulic control of the valve is carried out through the actuation of the valve spool by the use of solenoids (5). A solenoid is a converter which converts electrical energy into mechanical energy. The energised solenoid causes the oil-immersed magnetic piston to make a linear stroke movement. It uses the guide rod (6) to move the valve spool into the desired position. This causes the nominal flow directions between the respective ports to be released or closed. To obtain the valves' optimum switching capacity, the pressure-tight chamber of the pole tube should always be filled with oil.

The valve spool is pushed back into the starting position by the appropriate return spring after de-energization of solenoid.

The manual override (7) enables valve operation without energising the solenoid.

Without return spring with detent "OF"

This alternative describes the so-called impulse valve. This is a 4/2-directional valve with 2 solenoids and detent. The detents are used to lock the valve spool in the respective switching position. There is no need to permanently energise the solenoids, which consequently contributes to energy-saving operation.

SECTION VIEW

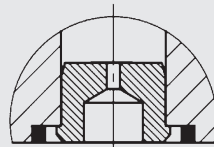
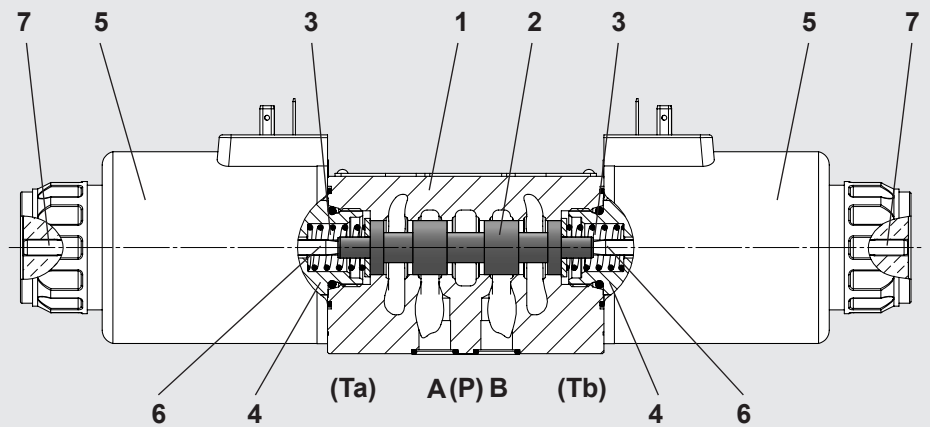

Orifice insert

Used to reduce nominal flows that are too high and outside of the valve's operating limits.

TECHNICAL DATA

General specifications			
MTTF _d :		According to EN ISO 13849-1:2015 Tables C1 & C2	
Ambient temperature range:	[°C]	-20 to +60	
Installation position:		No orientation restrictions	
Weight:	[kg]	4.0 with one solenoid; 6.0 with two solenoids	
Material:	Valve housing:	Cast iron	
	Pole tube:	Steel	
	Coil housing:	Steel	
	Name plate:	Aluminium	
Surface coating:	Valve housing:	Phosphate plated	
	Pole tube:	Zn-coating	
	Coil housing:	ZnNi-coating	
Hydraulic specifications			
Operating pressure:	[bar]	Port A, B, P:	$p_{\max} = 350$
		Port T:	$p_{\max} = 210$
Nominal flow:	[l/min]	See performance limits on page 5	
Operating fluid:		Hydraulic oil to DIN 51524 Part 1, 2 and 3	
Media operating temperature range:	[°C]	-20 to +80	
Viscosity range:	[mm ² /s]	10 to 500	
Permitted contamination level of operating fluid:		Class 20/18/15 according to ISO 4406	
Max. switching frequency:	[1/h]	15,000	
Manual override:		Up to approx. 50 bar tank pressure available	
Sealing material:		FKM, NBR	
Electrical specifications			
Switching time:	[ms]	Energised:	approx. 80 – 120
		De-energised:	approx. 70 – 110
Type of voltage:		DC	
Rated voltage:	[V]	12, 24, 96, 205	
Voltage tolerance:	[%]	±10	
Nominal power:	[W]	38	
Duty cycle:	[%]	100	
Max. surface temperature of the coil:	[°C]	150	
Degree of protection according to DIN EN 60529:	With electrical connection "G"	IP65 ²	
	With electrical connection "N"	IP65 / IP67 ²	
	With electrical connection "T"	IP65 ²	

¹ see "Conditions and Instructions for Valves" in brochure 53.000

² If installed correctly

PERFORMANCE

Pressure drop

measured at $v = 40 \text{ mm}^2/\text{s}$, $T = 43 \text{ }^\circ\text{C}$

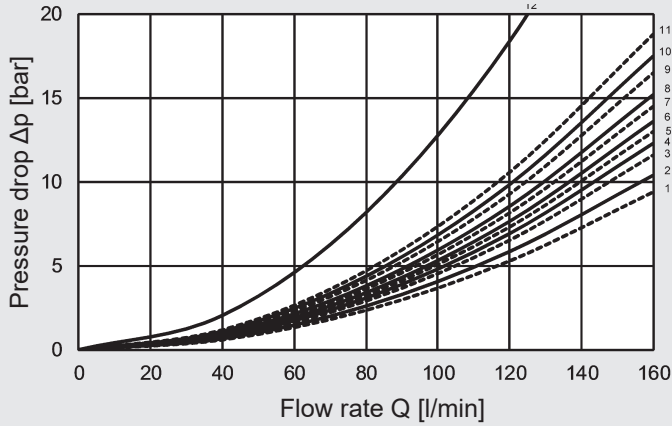

Performance limits

measured at $v = 40 \text{ mm}^2/\text{s}$, $T = 43 \text{ }^\circ\text{C}$

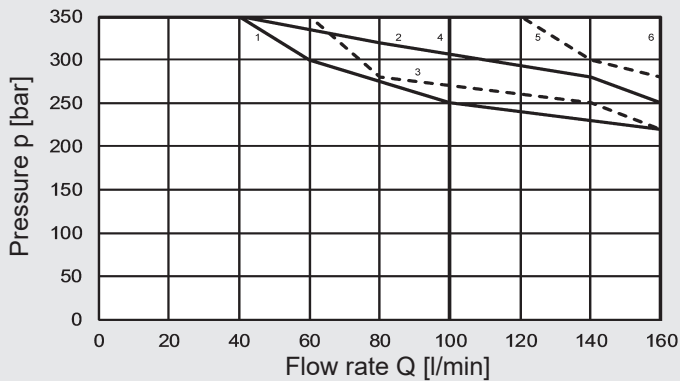

Performance assignment to the associated spools:

Spool	Pressure drop					Performance limits
	P→A	B→T	P→B	A→T	P→T	
AE	–	–	6	8	–	5
BE	4	8	–	–	–	6
BJ	4	3	–	–	–	3
C	9	8	5	5	–	6
D	9	11	8	8	–	6
D-OF	6	5	6	5	–	4
E, EA, EB	4	6	7	7	–	6
F	–	–	–	–	–	–
G, GA	9	10	9	11	12	–
H, HA, HB	1	5	2	7	11	6
J, JA, JB	4	2	7	3	–	6
L	4	7	4	2	–	2
M	2	9	2	9	–	6
P	–	–	–	–	–	–
Q, QA	4	7	6	7	–	5
R	5	–	9	7	–	1
U	4	3	4	7	–	2
Y	7	8	10	11	–	6

The performance limits were determined with solenoids at operating temperature and 10% low voltage.

The specified performance limits are applicable for operation with two directions of flow. The performance capacities may be lower when there is only one flow direction.

Restricted switching capacity for G96/G205 coils:

The max. permitted nominal flow specified in the diagram must be reduced by 10%. The switching times are extended.

DIMENSIONS

Interface according to ISO 4401-05-04-0-05

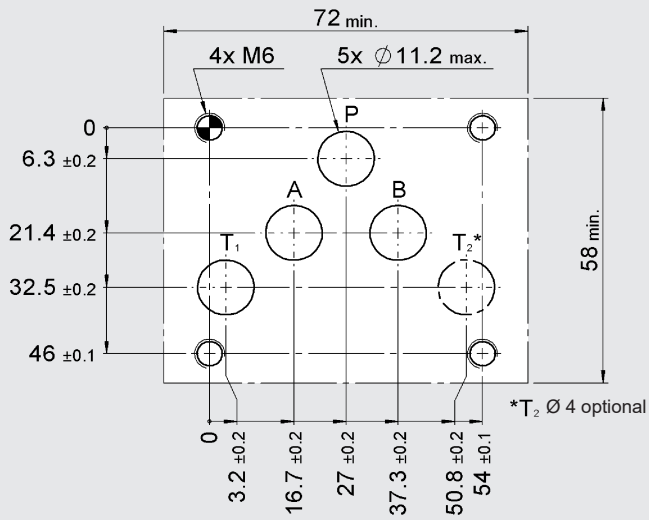

Mounting screws:
 (not included in delivery)
 DIN EN ISO 4762 – M6 x 40 – 10.9
 Tightening torque: 10 Nm

With two solenoids

Coil nut tightening torque
 6–7 Nm

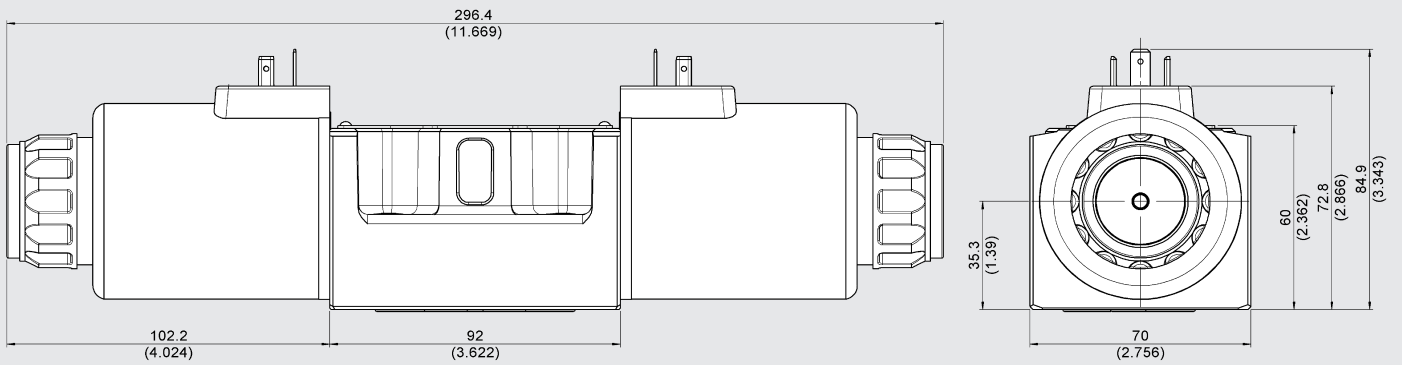
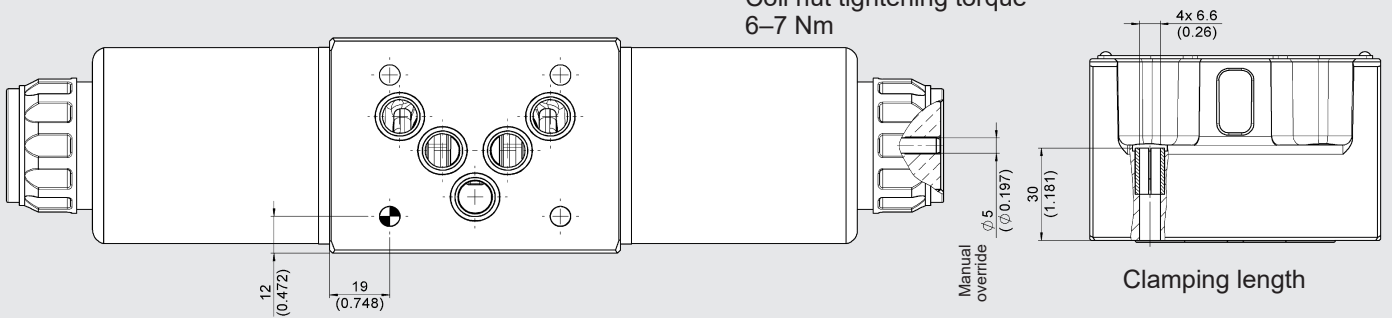

With one solenoid

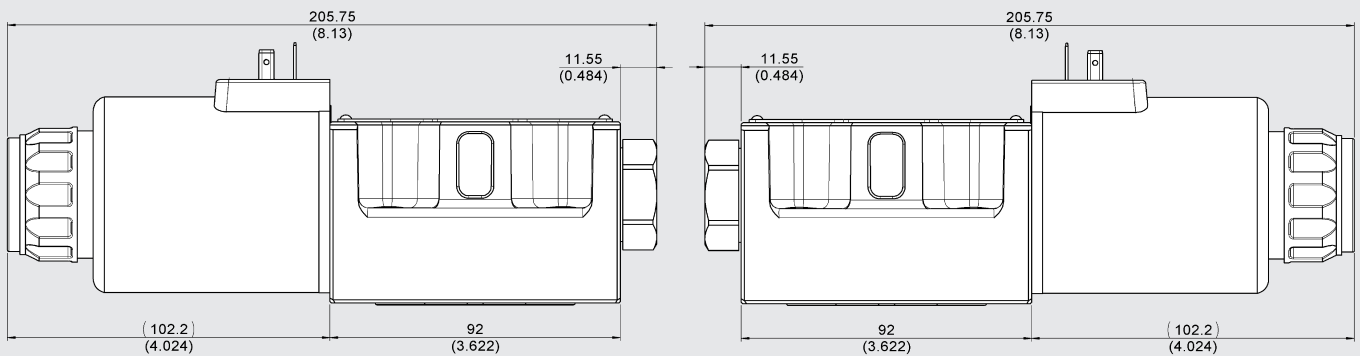

Valve with solenoid a

Valve with solenoid b

ELECTRICAL CONNECTIONS

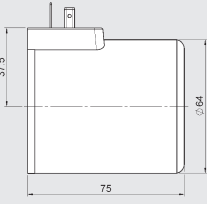
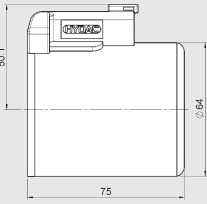
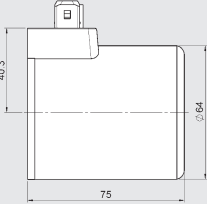
G Device connector DIN EN 175301-803 A		<ul style="list-style-type: none"> ● IP65
N Device connector, Deutsch (DT04-2P)		<ul style="list-style-type: none"> ● IP65 / IP67 ● Optional with suppressor diode
T Device connector Junior Timer (radial)		<ul style="list-style-type: none"> ● IP65 ● Optionally with suppressor diode

Other models on request

MANUAL OVERRIDES

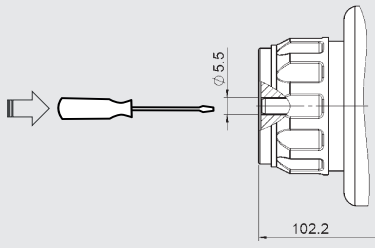
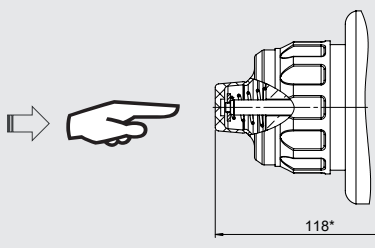
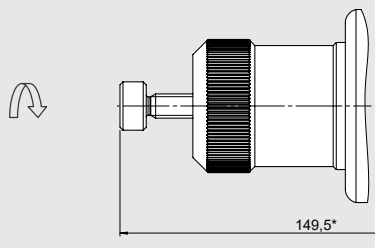
Standard with concealed manual override		Operation with tool
M1 with manual override		Operation without tool with spring return
M4 with knurled- head screw		Operation by turning the knurled-head screw

* Dimensions up to valve housing

In case of emergency, the valve can also be operated manually. There are different forms of manual override available.

The tank pressure should not exceed 50 bar. If the tank pressure is higher, the force required to operate the manual override increases accordingly.

For valves with two solenoids, simultaneous operation of both manual overrides is prohibited.

ACCESSORIES

	Designation	Part no.
Seal kits (4-part set)	12,42 x 1,78-NBR -80Sh	4348706
	12,4 2x 1,78-FKM -80Sh	4348705
Mounting screws (4 pcs)	DIN EN ISO 4762 - M6 x 40 - 10.9	3524314
Solenoid coils	COIL 12DG -75-3164 38W	4251228
	COIL 24DG -75-3164 38W	4251230
	COIL 96DG -75-3164 38W	4251232
	COIL 110DG -75-3164 38W	4251233
	COIL 205DG -75-3164 38W	4251255
	COIL 220DG -75-3164 38W	4251257
Seal kit for solenoid coil	Nut open, O-ring	4348711
	Nut with folding cap, O-ring	4348713
Connector	Z4 standard 2-pole without PE	394287
	ZW4 incl. rectifier	394293
	Z4L incl. LED	394285
Manual overrides	M1 with with pleated cap	912544
	M4 with knurled-head screw	4431668

NOTE

The information in this brochure relates to the operating conditions and applications described. For applications not described, please contact the relevant technical department. All technical details are subject to change without notice.